

***USER'S GUIDE***  
**HP Model 66111A**  
**Fast Transient DC Source**  
**HP Model 66311B**  
**Mobile Communications DC Source**

For instruments with Serial Numbers:

HP 66111A: US38460101 through US38460250

HP 66311B: US38440101 through US38442274



HP Part No. 5964-8106  
Microfiche No. 5964-8107  
Printed in USA: January 1999

---

# Warranty Information

## CERTIFICATION

*Hewlett-Packard Company certifies that this product met its published specifications at time of shipment from the factory. Hewlett-Packard further certifies that its calibration measurements are traceable to the United States National Bureau of Standards, to the extent allowed by the Bureau's calibration facility, and to the calibration facilities of other International Standards Organization members.*

## WARRANTY

This Hewlett-Packard hardware product is warranted against defects in material and workmanship for a period of three years from date of delivery. HP software and firmware products, which are designated by HP for use with a hardware product and when properly installed on that hardware product, are warranted not to fail to execute their programming instructions due to defects in material and workmanship for a period of 90 days from date of delivery. During the warranty period Hewlett-Packard Company will, at its option, either repair or replace products which prove to be defective. HP does not warrant that the operation for the software firmware, or hardware shall be uninterrupted or error free.

For warranty service, with the exception of warranty options, this product must be returned to a service facility designated by HP. Customer shall prepay shipping charges by (and shall pay all duty and taxes) for products returned to HP for warranty service. Except for products returned to Customer from another country, HP shall pay for return of products to Customer.

Warranty services outside the country of initial purchase are included in HP's product price, only if Customer pays HP international prices (defined as destination local currency price, or U.S. or Geneva Export price).

If HP is unable, within a reasonable time to repair or replace any product to condition as warranted, the Customer shall be entitled to a refund of the purchase price upon return of the product to HP.

## LIMITATION OF WARRANTY

The foregoing warranty shall not apply to defects resulting from improper or inadequate maintenance by the Customer, Customer-supplied software or interfacing, unauthorized modification or misuse, operation outside of the environmental specifications for the product, or improper site preparation and maintenance. NO OTHER WARRANTY IS EXPRESSED OR IMPLIED. HP SPECIFICALLY DISCLAIMS THE IMPLIED WARRANTIES OF MERCHANTABILITY AND FITNESS FOR A PARTICULAR PURPOSE.

## EXCLUSIVE REMEDIES

THE REMEDIES PROVIDED HEREIN ARE THE CUSTOMER'S SOLE AND EXCLUSIVE REMEDIES. HP SHALL NOT BE LIABLE FOR ANY DIRECT, INDIRECT, SPECIAL, INCIDENTAL, OR CONSEQUENTIAL DAMAGES, WHETHER BASED ON CONTRACT, TORT, OR ANY OTHER LEGAL THEORY.

## ASSISTANCE

The above statements apply only to the standard product warranty. Warranty options, extended support contacts, product maintenance agreements and customer assistance agreements are also available. Contact your nearest Hewlett-Packard Sales and Service office for further information on HP's full line of Support Programs.

---

## Safety Summary

*The following general safety precautions must be observed during all phases of operation of this instrument. Failure to comply with these precautions or with specific warnings elsewhere in this manual violates safety standards of design, manufacture, and intended use of the instrument. Hewlett-Packard Company assumes no liability for the customer's failure to comply with these requirements.*

### **GENERAL**

This product is a Safety Class 1 instrument (provided with a protective earth terminal). The protective features of this product may be impaired if it is used in a manner not specified in the operation instructions.

Any LEDs used in this product are Class 1 LEDs as per IEC 825-1.

### **ENVIRONMENTAL CONDITIONS**

This instrument is intended for indoor use in an installation category II, pollution degree 2 environment. It is designed to operate at a maximum relative humidity of 95% and at altitudes of up to 2000 meters. Refer to the specifications tables for the ac mains voltage requirements and ambient operating temperature range.

### **BEFORE APPLYING POWER**

Verify that the product is set to match the available line voltage, the correct fuse is installed, and all safety precautions are taken. Note the instrument's external markings described under "Safety Symbols".

### **GROUND THE INSTRUMENT**

To minimize shock hazard, the instrument chassis and cover must be connected to an electrical ground. The instrument must be connected to the ac power mains through a grounded power cable, with the ground wire firmly connected to an electrical ground (safety ground) at the power outlet. Any interruption of the protective (grounding) conductor or disconnection of the protective earth terminal will cause a potential shock hazard that could result in personal injury.

**ATTENTION: Un circuit de terre continu est essentiel en vue du fonctionnement sécuritaire de l'appareil. Ne jamais mettre l'appareil en marche lorsque le conducteur de mise ... la terre est d,branch,.**

### **FUSES**

Only fuses with the required rated current, voltage, and specified type (normal blow, time delay, etc.) should be used. Do not use repaired fuses or short-circuited fuseholders. To do so could cause a shock or fire hazard.

### **DO NOT OPERATE IN AN EXPLOSIVE ATMOSPHERE**

Do not operate the instrument in the presence of flammable gases or fumes.

### **DO NOT REMOVE THE INSTRUMENT COVER**

Operating personnel must not remove instrument covers. Component replacement and internal adjustments must be made only by qualified service personnel.

*Instruments that appear damaged or defective should be made inoperative and secured against unintended operation until they can be repaired by qualified service personnel.*

## SAFETY SYMBOLS

	Direct current
	Alternating current
	Both direct and alternating current
	Three-phase alternating current
	Earth (ground) terminal
	Protective earth (ground) terminal
	Frame or chassis terminal
	Terminal is at earth potential. Used for measurement and control circuits designed to be operated with one terminal at earth potential.
	Terminal for Neutral conductor on permanently installed equipment
	Terminal for Line conductor on permanently installed equipment
	On (supply)
	Off (supply)
	Standby (supply). Units with this symbol are not completely disconnected from ac mains when this switch is off. To completely disconnect the unit from ac mains, either disconnect the power cord or have a qualified electrician install an external switch.
	In position of a bi-stable push control
	Out position of a bi-stable push control
	Caution, risk of electric shock
	Caution, hot surface
	Caution (refer to accompanying documents)

### **WARNING**

The **WARNING** sign denotes a hazard. It calls attention to a procedure, practice, or the like, which, if not correctly performed or adhered to, could result in personal injury. Do not proceed beyond a **WARNING** sign until the indicated conditions are fully understood and met.

### **Caution**

The **CAUTION** sign denotes a hazard. It calls attention to an operating procedure, or the like, which, if not correctly performed or adhered to, could result in damage to or destruction of part or all of the product. Do not proceed beyond a **CAUTION** sign until the indicated conditions are fully understood and met.

# Declaration Page

## DECLARATION OF CONFORMITY according to ISO/IEC Guide 22 and EN 45014

Manufacturer's Name: Hewlett-Packard Company  
Manufacturer's Address: 150 Green Pond Road  
Rockaway, New Jersey 07866  
U.S.A.

declares that the Product

Product Name: a) Dynamic Measurement DC Source  
b) System DC Power Supply  
c) Remote Front Panel

Model Number: a) HP 66311A, 66311B, 66312A, 66111A  
b) HP 6612B, 6611C, 6612C, 6613C, 6614C  
c) HP 14575A

conforms to the following Product Specifications:

Safety: IEC 1010-1:1990+A1(1992) / EN 61010-1:1993

EMC: CISPR 11:1990 / EN 55011:1991 - Group 1 Class B  
IEC 801-2:1991 / EN 50082-1:1992 - 4 kV CD, 8 kV AD  
IEC 801-3:1984 / EN 50082-1:1992 - 3 V / m  
IEC 801-4:1988 / EN 50082-1:1992 - 0.5 kV Signal Lines  
1 kV Power Lines

Supplementary Information:

The product herewith complies with the requirements of the Low Voltage Directive 73/23/EEC and the EMC Directive 89/336/EEC and carries the CE-marking accordingly.

New Jersey  
Location

April, 1998  
Date

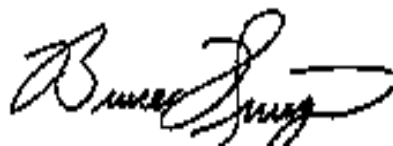

Bruce Krueger / Quality Manager

European Contact: Your local Hewlett-Packard Sales and Service Office or Hewlett-Packard GmbH,  
Department TRE, Herrenberger Strasse 130, D-71034 Boeblingen (FAX:+49-7031-14-3143)

---

## Acoustic Noise Information

### Herstellerbescheinigung

Diese Information steht im Zusammenhang mit den Anforderungen der Maschinenläminformationsverordnung vom 18 Januar 1991.

- \* Schalldruckpegel  $L_p < 70$  dB(A)
- \* Am Arbeitsplatz
- \* Normaler Betrieb
- \* Nach EN 27779 (Typprüfung).

### Manufacturer's Declaration

This statement is provided to comply with the requirements of the German Sound Emission Directive, from 18 January 1991.

- \* Sound Pressure  $L_p < 70$  dB(A)
- \* At Operator Position
- \* Normal Operation
- \* According to EN 27779 (Type Test).

---

## Printing History

The edition and current revision of this manual are indicated below. Reprints of this manual containing minor corrections and updates may have the same printing date. Revised editions are identified by a new printing date. A revised edition incorporates all new or corrected material since the previous printing date.

Changes to the manual occurring between revisions are covered by change sheets shipped with the manual. In some cases, the manual change applies only to specific instruments. Instructions provided on the change sheet will indicate if a particular change applies only to certain instruments.

This document contains proprietary information protected by copyright. All rights are reserved. No part of this document may be photocopied, reproduced, or translated into another language without the prior consent of Hewlett-Packard Company. The information contained in this document is subject to change without notice.

---

# Table of Contents

Warranty Information	2
Safety Summary	3
Declaration Page	5
Acoustic Noise Information	6
Printing History	6
Table of Contents	7
<b>1 - QUICK REFERENCE</b>	<b>13</b>
The Front Panel - At a Glance	13
The Rear Panel - At a Glance	14
Instrument Configuration	14
Front Panel Number Entry	15
Front Panel Annunciators	16
Immediate Action Keys	16
Front Panel Menus - At a Glance	17
SCPI Programming Commands - At a Glance	18
<b>2 - GENERAL INFORMATION</b>	<b>19</b>
Document Orientation	19
Safety Considerations	20
Options and Accessories	20
Description	21
Capabilities	21
Front Panel Controls	22
Remote Programming	22
Output Characteristic	22
<b>3 - INSTALLATION</b>	<b>25</b>
Installation and Operating Checklist	25
Inspection	26
Damage	26
Packaging Material	26
Items Supplied	26
Cleaning	26
Location	27
Bench Operation	27
Rack Mounting	27
Input Connections	28
Connect the Power Cord	28
Output Connections	28
Current Ratings	28
Voltage Drops and Lead Resistance	28
Remote Sensing	29
Remote Sense Leads	30
Maintaining Stability while Remote Sensing	32
Open Sense Lead Protection	32
Output Compensation (High Mode/Low Mode)	34
Local Sensing	34
OVP Considerations	35
External Protection Connections	36
Digital I/O Connections	37

<b>Controller Connections</b>	<b>38</b>
HP-IB Interface	38
RS-232 Interface	38
<b>4 - TURN-ON CHECKOUT</b>	<b>39</b>
<b>Checkout Procedure</b>	<b>39</b>
<b>In Case of Trouble</b>	<b>41</b>
Selftest Error Messages	41
Runtime Error Messages	41
Line Fuse	42
<b>5 - FRONT PANEL OPERATION</b>	<b>43</b>
<b>Introduction</b>	<b>43</b>
<b>Front Panel Description</b>	<b>43</b>
<b>System Keys</b>	<b>45</b>
<b>Function Keys</b>	<b>46</b>
Immediate Action Keys	46
Scrolling Keys	46
Metering Keys	47
Output Control Keys	48
<b>Entry Keys</b>	<b>49</b>
<b>Examples of Front Panel Programming</b>	<b>50</b>
1 - Setting the Output Voltage, Current, and Compensation	50
2 - Querying and Clearing Output Protection and Errors	51
3 - Making Front Panel Measurements	52
4 - Programming External Protection and the Digital Port Functions	54
5 - Setting the HP-IB Address and RS-232 Parameters	54
6 - Saving and Recalling Operating States	55
<b>6 - INTRODUCTION TO PROGRAMMING</b>	<b>57</b>
<b>HP-IB Capabilities of the DC Source</b>	<b>57</b>
HP-IB Address	57
<b>RS-232 Capabilities of the DC Source</b>	<b>57</b>
RS-232 Data Format	57
Baud Rate	57
RS-232 Flow Control	58
<b>Introduction to SCPI</b>	<b>58</b>
SCPI References	58
HP-IB References	58
Conventions Used in This Guide	59
<b>Types of SCPI Commands</b>	<b>59</b>
Multiple Commands in a Message	60
Moving Among Subsystems	60
Including Common Commands	61
Using Queries	61
<b>Types of SCPI Messages</b>	<b>61</b>
The Message Unit	62
Headers	62
Query Indicator	62
Message Unit Separator	62
Root Specifier	62
Message Terminator	62
<b>SCPI Data Formats</b>	<b>63</b>
Numerical Data Formats	63



Suffixes and Multipliers	63
Response Data Types	63
<b>SCPI Command Completion</b>	<b>64</b>
<b>Using Device Clear</b>	<b>64</b>
<b>RS-232 Troubleshooting</b>	<b>65</b>
<b>SCPI Conformance Information</b>	<b>65</b>
SCPI Confirmed Commands	65
Non-SCPI Commands	65
<b>7 - PROGRAMMING THE DC SOURCE</b>	<b>67</b>
<b>Introduction</b>	<b>67</b>
<b>Programming the Output</b>	<b>67</b>
Power-on Initialization	67
Enabling the Output	67
Output Voltage	68
Output Current	68
<b>Triggering Output Changes</b>	<b>69</b>
SCPI Triggering Nomenclature	69
Output Trigger System Model	69
Setting the Voltage or Current Trigger Levels	69
Initiating the Output Trigger System	70
Generating Triggers	70
<b>Making Measurements</b>	<b>71</b>
Controlling Measurement Samples	71
Current Ranges and Measurement Detector (HP Model 66311B Only)	72
Window Functions	72
Voltage and Current Measurements	73
Pulse Measurements (HP Model 66311B Only)	73
Returning All Measurement Data From the Data Buffer	74
<b>Internally Triggered Measurements</b>	<b>75</b>
SCPI Triggering Nomenclature	75
Measurement Trigger System Model	75
Initiating the Measurement Trigger System	75
Selecting the Measurement Trigger Source	76
Generating Measurement Triggers	76
Pre-event and Post-event Triggering	78
<b>Programming the Status Registers</b>	<b>79</b>
Power-On Conditions	79
Operation Status Group	81
Questionable Status Group	82
Standard Event Status Group	82
Status Byte Register	82
Determining the Cause of a Service Interrupt	83
Servicing Operation Status and Questionable Status Events	83
Monitoring Both Phases of a Status Transition	84
<b>Inhibit/Fault Indicator</b>	<b>84</b>
Remote Inhibit (RI)	84
Discrete Fault Indicator (DFI)	85
Using the Inhibit/Fault Port as a Digital I/O	85
<b>8 - LANGUAGE DICTIONARY</b>	<b>87</b>
<b>Introduction</b>	<b>87</b>
Subsystem Commands	87
Common Commands	91

Programming Parameters	91
<b>Calibration Commands</b>	<b>92</b>
CALibrate:CURRent	92
CALibrate:CURRent:MEASure:LOWRange	92
CALibrate:CURRent:MEASure:AC	92
CALibrate:DATA	93
CALibrate:LEVel	93
CALibrate:PASSword	93
CALibrate:SAVE	93
CALibrate:STATe	94
CALibrate:VOLTage	94
CALibrate:VOLTage:PROTection	94
<b>Display Commands</b>	<b>95</b>
DISPlay	95
DISPlay:MODE	95
DISPlay:TEXT	95
<b>Format Commands</b>	<b>96</b>
FORMat	96
FORMat:BORDer	96
<b>Measurement Commands</b>	<b>97</b>
MEASure:ARRay:CURRent? FETCh:ARRay:CURRent?	97
MEASure:ARRay:VOLTage? FETCh:ARRay:VOLTage?	97
MEASure:CURRent? FETCh:CURRent?	98
MEASure:CURRent:ACDC? FETCh:CURRent:ACDC?	98
MEASure:CURRent:HIGH? FETCh:CURRent:HIGH?	98
MEASure:CURRent:LOW? FETCh:CURRent:LOW?	99
MEASure:CURRent:MAXimum? FETCh:CURRent: MAXimum?	99
MEASure:CURRent:MINimum? FETCh:CURRent:MINimum?	99
MEASure:VOLTage? FETCh:VOLTage?	100
MEASure:VOLTage:ACDC? FETCh:VOLTage:ACDC?	100
MEASure:VOLTage:HIGH? FETCh:VOLTage:HIGH?	100
MEASure:VOLTage:LOW? FETCh:VOLTage:LOW?	101
MEASure:VOLTage:MAXimum? FETCh:VOLTage:MAXimum?	101
MEASure:VOLTage:MINimum? FETCh:VOLTage:MINimum?	101
SENSe:CURRent:DETEctor	102
SENSe:CURRent:RANGe	102
SENSe:FUNCTion	103
SENSe:PROTection:STATe	103
SENSe:SWEEp:OFFSet:POINts	103
SENSe:SWEEp:POINts	103
SENSe:SWEEp:TINterval	104
SENSe:WINDow	104
<b>Output Commands</b>	<b>105</b>
OUTPut	105
OUTPut:DFI	105
OUTPut:DFI:SOURce	105
OUTPut:PON:STATe	106
OUTPut:PROTection:CLEAr	106
OUTPut:PROTection:DELAy	106
OUTPut:RI:MODE	107
OUTPut:TYPE	107
[SOURce:]CURRent	108
[SOURce:]CURRent:PROTection:STATe	108
[SOURce:]CURRent:TRIGger	108
[SOURce:]DIGital:DATA	109

[SOURce:]DIGital:FUNCTion	109
[SOURce:]VOLTage	109
[SOURce:]VOLTage:PROTection	110
[SOURce:]VOLTage:PROTection:STATe	110
[SOURce:]VOLTage:TRIGger	110
<b>Status Commands</b>	<b>111</b>
STATus:PRESet	111
STATus:OPERation?	111
STATus:OPERation:CONDition?	111
STATus:OPERation:ENABle	112
STATus:OPERation:NTR STATus:OPERation:PTR	112
STATus:QUEStionable?	113
STATus:QUEStionable:CONDition?	113
STATus:QUEStionable:ENABle	113
STATus:QUEStionable:NTR STATus:QUEStionable:PTR	114
<b>System Commands</b>	<b>115</b>
SYSTem:ERRor?	115
SYSTem:LANGuage	115
SYSTem:VERSIon?	115
SYSTem:LOCal	116
SYSTem:REMote	116
SYSTem:RWLock	116
<b>Trigger Commands</b>	<b>117</b>
ABORT	117
INITiate:SEquence INITiate:NAME	117
INITiate:CONTinuous:SEquence1 INITiate:CONTinuous:NAME TRANsient	117
TRIGger	118
TRIGger:SOURce	118
TRIGger:SEquence2 TRIGger:ACquire	118
TRIGger:SEquence2:COUNT:CURRent TRIGger:ACquire:COUNT:CURRent	119
TRIGger:SEquence2:COUNT:VOLTage TRIGger:ACquire:COUNT:VOLTage	119
TRIGger:SEquence2:HYSTeresis:CURRent TRIGger:ACquire:HYSTeresis:CURRent	120
TRIGger:SEquence2:HYSTeresis:VOLTage TRIGger:ACquire:HYSTeresis:VOLTage	120
TRIGger:SEquence2:LEVel:CURRent TRIGger:ACquire:LEVel:CURRent	121
TRIGger:SEquence2:LEVel:VOLTage TRIGger:ACquire:LEVel:VOLTage	121
TRIGger:SEquence2:SLOPe:CURRent TRIGger:ACquire:SLOPe:CURRent	122
TRIGger:SEquence2:SLOPe:VOLTage TRIGger:ACquire:SLOPe:VOLTage	122
TRIGger:SEquence2:SOURce TRIGger:ACquire:SOURce	123
TRIGger:SEquence1:DEFine TRIGger:SEquence2:DEFine	123
<b>Common Commands</b>	<b>124</b>
*CLS	124
*ESE	124
*ESR?	125
*IDN?	125
*OPC	125
*OPT?	126
*PSC	126
*RCL	126
*RST	127
*SAV	127
*SRE	128
*STB?	128
*TRG	129
*TST?	129
*WAI	129

<b>Additional Commands</b>	<b>130</b>
INSTrument:STATe	130
OUTPut:PROTection:TRIPped?	130
CURRent:LIMit:HIGH?	130
CURRent:LIMit:LOW?	130
CURRent:PROTection:TRIPped?	131
VOLTage:LIMit:HIGH?	131
VOLTage:LIMit:LOW?	131
VOLTage:PROTection:TRIPped?	131
<b>A - SPECIFICATIONS</b>	<b>133</b>
Specifications	133
Supplemental Characteristics	134
<b>B - VERIFICATION AND CALIBRATION</b>	<b>137</b>
Introduction	137
Equipment Required	137
Test Setup	137
Performing the Verification Tests	138
Turn-On Checkout	138
Check the Language Setting	139
Voltage Programming and Measurement Accuracy	139
Current Programming and Measurement Accuracy	139
Restore the Language Setting	140
Performing the Calibration Procedure	142
Front Panel Calibration Menu	142
Front Panel Calibration Procedure	143
Calibration Error Messages	146
Changing the Calibration Password	146
Calibration Over the HP-IB	146
<b>C - ERROR MESSAGES</b>	<b>147</b>
<b>D - EXAMPLE PROGRAMS</b>	<b>151</b>
<b>E - LINE VOLTAGE CONVERSION</b>	<b>161</b>
<b>F - COMPATIBILITY LANGUAGE</b>	<b>163</b>
<b>INDEX</b>	<b>169</b>



## Quick Reference

### The Front Panel - At a Glance

**1** A 14-character display shows output measurements and programmed values.

**2** Annunciators indicate operating modes and status conditions.

**3** Rotary control sets voltage, current, and menu parameters.

Use  and  to set the resolution; then adjust the value with the knob.

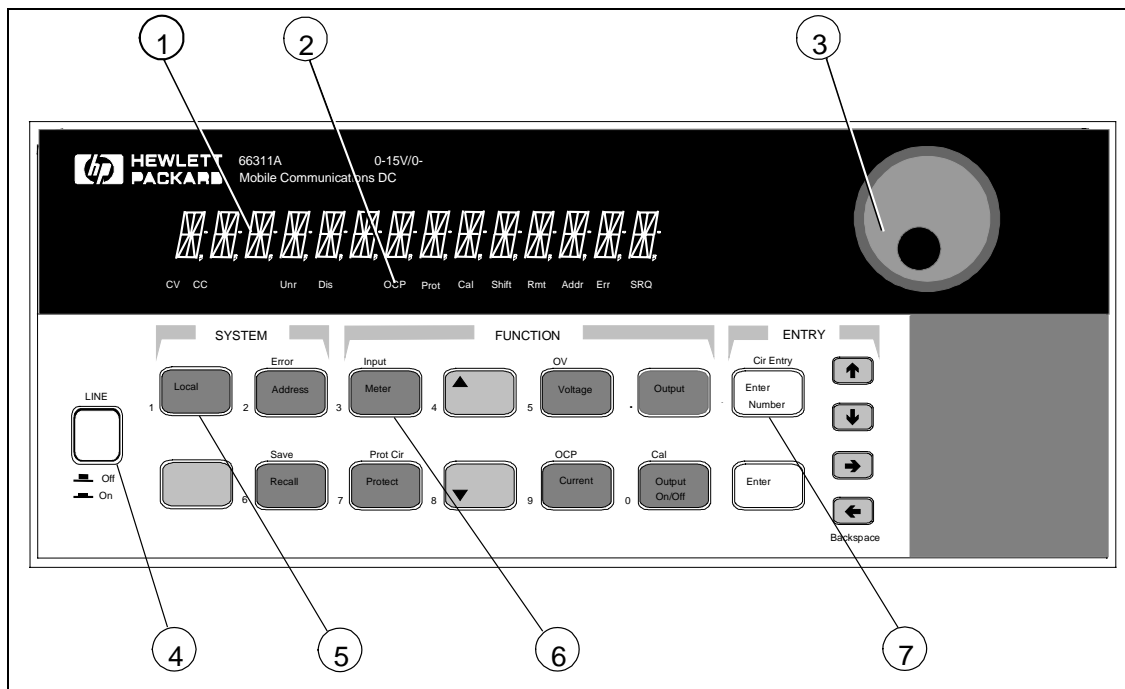



**4** Turns the dc source on and off.





**5** System keys:

- ◆ return to Local mode
- ◆ set the HP-IB address
- ◆ set the RS-232 interface
- ◆ display SCPI error codes
- ◆ save and recall instrument states
- ◆ select programming language.

**6** Function keys:

- ◆ enable/disable the output
- ◆ select metering functions
- ◆ program voltage and current
- ◆ set and clear protection functions
- ◆  and  scroll through the front panel menu commands.

**7** Entry keys:

- ◆ enter values
- ◆ increment or decrement values
- ◆  and  select front panel menu parameters.
- ◆  and  select a digit in the numeric entry field.

## The Rear Panel - At a Glance

- 1** AC calibration switch (see appendix B).      **2** HP-IB (IEEE-488) interface connector.      **3** RS-232 interface connector.      **4** INH/FLT (remote INHibit / internal FauLT) connector. Connector plug is removable.

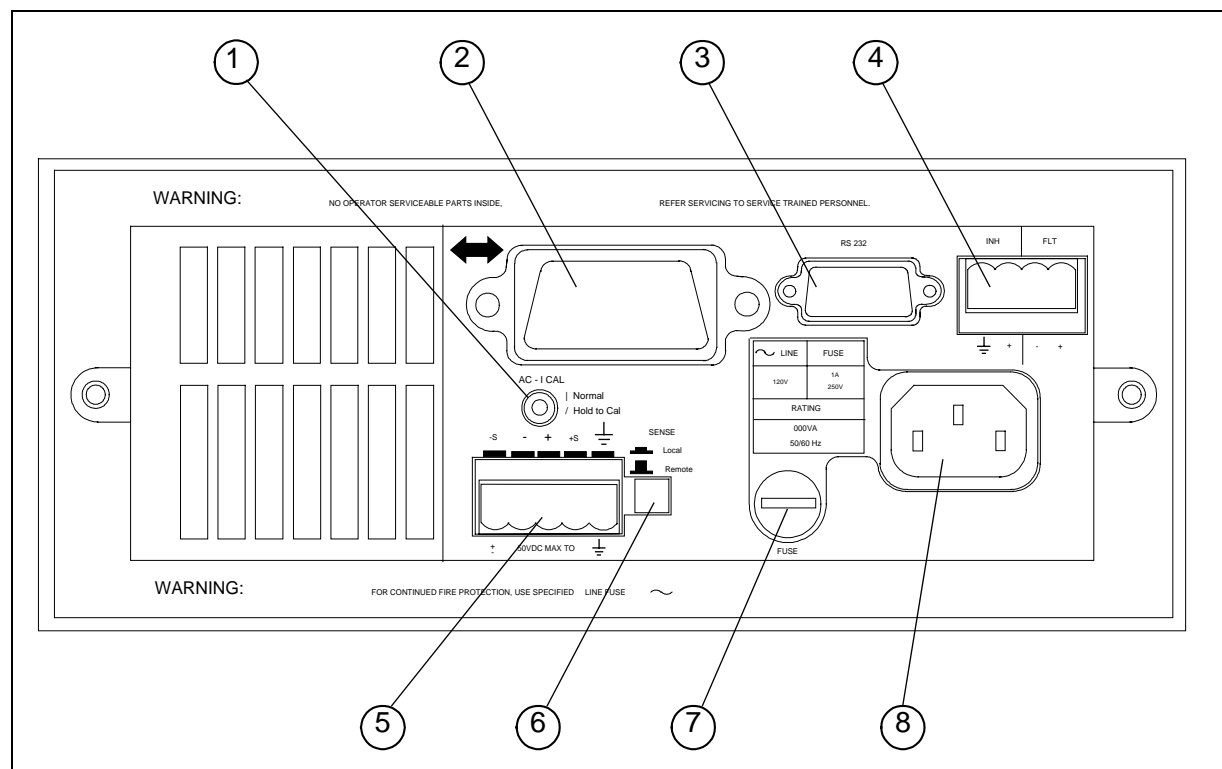

- 5** Output and Remote sense connector. Connector plug is removable.      **6** Remote or Local sense switch      **7** Fuse holder      **8** Power cord connector (IEC 320)

## Instrument Configuration

### Use the front panel Address key to configure the interface

Refer to "Front Panel Menus - At a Glance"

- ◆ Select either the HP-IB or RS-232 interface.
- ◆ Enter the HP-IB bus address.
- ◆ Configure the RS-232 baud rate, parity, and flow control.
- ◆ Select either the SCPI or COMPatibility programming language.
- ◆ Enable the optional HP 14575A remote front panel.

## Front Panel Number Entry

Enter numbers from the front panel using **one** the following methods:

### Use the arrow keys and knob to change voltage or current settings

**NOTE:** The output must be ON to see the displayed values change in Meter mode. With the output enabled, this method changes the output voltage or current immediately.

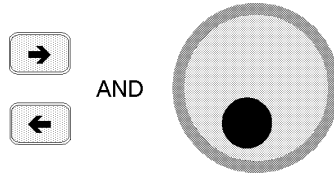

### Use the Function keys and knob to change the displayed settings

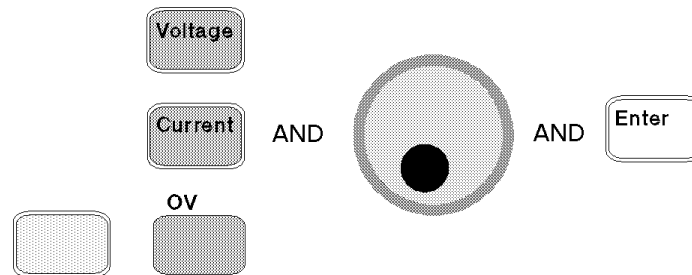

### Use the arrow keys to edit individual digits in the displayed setting

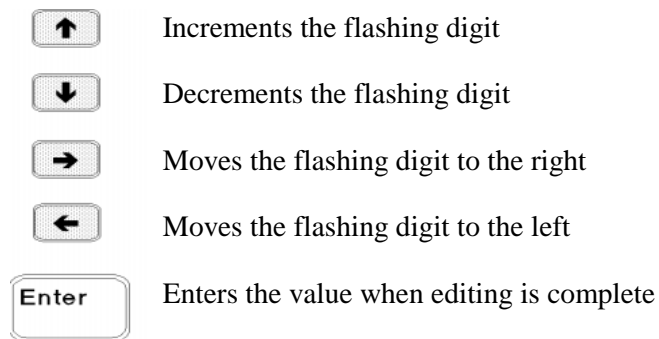

### Use the Function keys and Entry keys to enter a new value

**NOTE:** If you make a mistake, use the Backspace key to delete the number, or press the Meter key to return to meter mode.

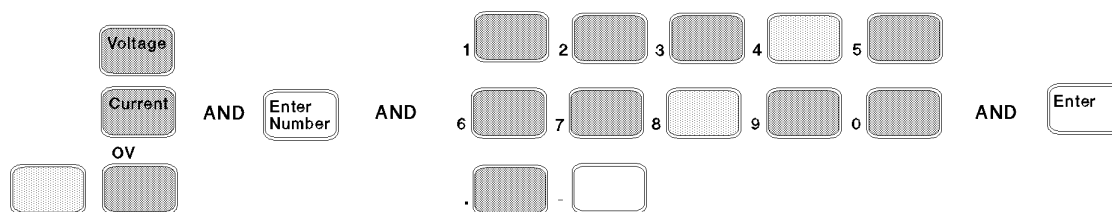

## Front Panel Annunciators

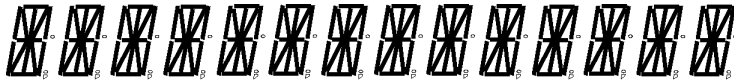

CV CC                      Unr Dis                      OCP Prot Cal Shift Rmt Addr Err SRQ

<b>CV</b>	The output is operating in constant voltage mode.
<b>CC</b>	The output is operating in constant current mode.
<b>Unr</b>	The output is unregulated.
<b>Dis</b>	The output is OFF. Press the Output On/Off key to turn the output on.
<b>OCP</b>	The over-current protection state is ON. Press the OCP key to turn over-current protection off.
<b>Prot</b>	Indicates that the output has been disabled by one of the protection features. Press the Prot Clear key to clear the protection condition.
<b>Cal</b>	Calibration mode is ON. Scroll to the Cal Off command and press the Enter key to exit the calibration mode.
<b>Shift</b>	The Shift key has been pressed.
<b>Rmt</b>	The selected Remote programming interface (either HP-IB or RS-232) is active. Press the Local key to return the unit to front panel control.
<b>Addr</b>	The interface is addressed to talk or listen.
<b>Err</b>	There is an error in the SCPI error queue. Press the Error key to view the error code.
<b>SRQ</b>	The interface is requesting service.



## Immediate Action Keys

<input type="checkbox"/> Output On/Off	A toggle switch that turns the output of the dc source on or off.
<input type="checkbox"/> Local	Activates front panel control when the unit is in remote mode (unless a Lockout command is in effect).
<input type="checkbox"/> Shift <input type="checkbox"/> Prot Clr	Resets the protection circuit and allows the unit to return to its last programmed state.
<input type="checkbox"/> Shift <input type="checkbox"/> OCP	A toggle switch that enables or disables overcurrent protection.



## Front Panel Menus - At a Glance

Address		<i>ADDRESS 7</i>	Sets the HP-IB Address
	▼	<i>INTF HPIB</i>	Selects an interface (HPIB or RS232)
	▼	<i>BAUDRATE 300</i>	Selects baud rate (300, 600, 1200, 2400, 4800, 9600)
	▼	<i>PARITY NONE</i>	Selects message parity (NONE, EVEN, ODD, MARK, SPACE)
	▼	<i>FLOW NONE</i>	Selects flow control (XON-XOFF, RTS-CTS, DTR-DSR, NONE)
	▼	<i>LANG SCPI</i>	Selects language (SCPI or COMP)
	▼	<i>REMOTE FP OFF</i>	Enables or disables HP 14575A front panel interface (ON or OFF)
Recall		<i>*RCL 0</i>	Recalls instrument state
Shift	Save	<i>*SAV 0</i>	Saves present instrument state
Shift	Error	<i>ERROR 0</i>	Displays errors in SCPI error queue
Meter		<i>12.000V 0.204A</i>	Measures output voltage and current
	▼	<i>12.500V MAX</i>	Measures peak output voltage <sup>1</sup>
	▼	<i>1.000V MIN</i>	Measures minimum output voltage <sup>1</sup>
	▼	<i>12.330V HIGH</i>	Measures the high level of a voltage pulse waveform <sup>1</sup>
	▼	<i>0.080V LOW</i>	Measures the low level of a voltage pulse waveform <sup>1</sup>
	▼	<i>12.000V RMS</i>	Measures rms voltage <sup>1</sup>
	▼	<i>0.350A MAX</i>	Measures peak output current <sup>1</sup>
	▼	<i>0.050A MIN</i>	Measures minimum output current <sup>1</sup>
	▼	<i>0.400A HIGH</i>	Measures the high level of a current pulse waveform <sup>1</sup>
	▼	<i>0.012A LOW</i>	Measures the low level of a current pulse waveform <sup>1</sup>
	▼	<i>0.210A RMS</i>	Measures rms current <sup>1</sup>
Voltage		<i>VOLT 20.000</i>	Sets the output voltage
Current		<i>CURR 2.000</i>	Sets the output current
Protect		<i>OVERCURRENT</i>	Protection status (example shows overcurrent tripped)
Output		<i>*RST</i>	Places the dc source in the factory-default state
	▼	<i>PON:STATE RST</i>	Select the power-on state command (RST or RCL0)
	▼	<i>PROT:DLY 0.08</i>	Sets the output protection delay in seconds
	▼	<i>SENSE:PROT ON</i>	Sets the broken sense lead detect circuit on
	▼	<i>RI LATCHING</i>	Sets the remote inhibit mode (LATCHING, LIVE, or OFF)
	▼	<i>DFI OFF</i>	Sets the discrete fault indicator state (ON or OFF)
	▼	<i>DFI:SOUR OFF</i>	Selects the DFI source (QUES, OPER, ESB, RQS, or OFF)
	▼	<i>PORT RIDFI</i>	Sets the output port functions (RIDFI or DIGIO)
	▼	<i>DIGIO 7</i>	Sets and reads the I/O port value (0 through 7)
	▼	<i>TYPE:CAP LOW</i>	Sets the output capacitance compensation (HIGH or LOW)
Shift	OV	<i>VOLT:PROT 22</i>	Sets the overvoltage protection level
	▼	<i>PROT:STAT ON</i>	Enables or disables overvoltage protection (ON or OFF)
Shift	Input	<i>CURR:RANG HIGH</i>	Sets the current range (HIGH, LOW, or AUTO) <sup>1</sup>
	▼	<i>CURR:DET ACDC</i>	Sets the current measurement detector (ACDC or DC) <sup>1</sup>
	▼	<i>TINT 46.8</i>	Sets the time interval for a front panel measurement in seconds
	▼	<i>POINT 2048</i>	Sets the buffer size for a front panel measurement
Shift	Cal	<i>CAL ON</i>	Accesses calibration menu (See Appendix B).

Use  and  to select parameters (table shows factory defaults). Use  to exit any menu.

<sup>1</sup>Only available on HP Model 66311B

## SCPI Programming Commands - At a Glance

**NOTE:** Some [optional] commands have been included for clarity. Refer to chapter 8 for a complete description of all programming commands.

### ABORt

#### CALibrate

```
:CURRent [:POSitive]
           :NEGAtive
           :MEASure :LOWRange1
           :AC1

:DATA <n>
:LEVel P1 | P2
:PASSword <n>
:SAVE
:STATe <bool> [, <n>]
:VOLTage [:DC]
           :PROTection
```

#### DISPlay

```
<bool>
:MODE NORMAl | TEXT
:TEXT <display_string>
```

#### FORMat

```
[:DATA] ASCII | REAL [,length]
:BORDer NORM | SWAP
```

#### INITiate

```
:SEquence[1|2]
:NAME TRANSient | ACQuire
:CONTinuous :SEquence[1], <bool>
           :NAME TRANSient, <bool>
```

#### MEASure | FETCh

```
:ARRay :CURRent?
           :VOLTage?
[:CURRent] [:DC]?
           :ACDC?1
           :HIGH?1
           :LOW?1
           :MAX?1
           :MIN?1
:VOLTage [:DC]?
           :ACDC?1
           :HIGH?1
           :LOW?1
           :MAX?1
           :MIN?1
```

#### OUTPut

```
<bool>
:DFI <bool>
           :SOURce QUES | OPER | ESB | RQS | OFF
:PON :STATe RST | RCL0
:PROTection :CLEAr
           :DELay <n>
:RI :MODE LATCHing | LIVE | OFF
:TYPE [:CAPacitance] HIGH | LOW
```

### SENSe

```
:CURRent :RANGe <n>1
           :DETEctor ACDC | DC1
:FUNCTion "VOLT" | "CURR"
:PROTection :STATe <bool>
:SWEEp :OFFSet :POINts <n>
           :POINts <n>
           :TINteRval <n>
:WINDow :TYPE "HANN" | "RECT"
[SOURce:] CURRent <n>
           :TRIGgered <n>
           :PROTection :STATe <bool>
DIGital :DATA <n>
           :FUNCTion RIDF | DIG
VOLTage <n>
           :TRIGgered <n>
           :PROTection <n>
           :STATe <bool>
```

### STATus

```
:PRESet
:OPERation [:EVENT]?
           :CONDition?
           :ENABle <n>
           :NTRAnSition <n>
           :PTRAnSition <n>
:QUESTionable [:EVENT]?
           :CONDition?
           :ENABle <n>
           :NTRAnSition <n>
           :PTRAnSition <n>
```

### SYSTEM

```
:ERRor?
:LANGUage SCPI | COMPAtibility
:VERSion?
:LOCAl
:REMote
:RWLock
```

### TRIGger

```
:SEquence2| :ACQuire [:IMMediate]
           :COUNT :CURRent <n>
           :VOLTage <n>
           :HYSTeresis:CURRent <n>
           :VOLTage <n>
           :LEVel :CURRent <n>
           :VOLTage <n>
           :SLOPe :CURRent POS | NEG | EITH
           :VOLTage POS | NEG | EITH
           :SOURce BUS | INTERNAL
[:SEquence1] :TRANSient[:IMMediate]
           :SOURce BUS
:SEquence1 :DEFine TRANSient
:SEquence2 :DEFine ACQuire
```

<sup>1</sup>Only available on HP Model 66311B

## General Information

---

### Document Orientation

This manual describes the operation of the HP Model 66111A Fast Transient and the HP Model 66311B Mobile Communications DC Source. Unless otherwise noted, these models will be referred to by the description "dc source" throughout this manual.

The following Getting Started Map will help you find the information you need to complete the specific task that you want to accomplish. Refer to the table of contents or index of each guide for a complete list of the information contained within.

#### Getting Started Map

Task	Where to find information
<b>Quick Reference Section</b>	Chapter 1
<b>Installing the unit</b> Line voltage connections Computer connections Load connections	Chapter 2
<b>Checking out the unit</b> Verifying proper operation Using the front panel Calibrating the unit	Chapter 3
<b>Using the front panel</b> Front panel keys Front panel examples	Chapter 5
<b>Using the programming interface</b> HP-IB interface RS-232 interface	Chapter 6
<b>Programming the unit using SCPI (and COMPatibility) commands</b> SCPI commands SCPI programming examples SCPI language dictionary	Chapters 7 and 8 for SCPI commands. Appendix D for SCPI examples Appendix F for COMPatibility commands
<b>Programming the unit using the HP VXI<i>plug&amp;play</i> instrument driver</b> Installing the instrument driver Instrument driver functions C/C++ example programs Visual BASIC example programs LabVIEW example programs HP VEE example programs	HP VXI <i>plug&amp;play</i> installation sheet and on-line help  <b>NOTE:</b> The driver must be installed on your pc to access the on-line information. Drivers for HP-UX are available on the web at <a href="http://www.hp.com/go/drivers">www.hp.com/go/drivers</a>

## Safety Considerations

This dc source is a Safety Class 1 instrument, which means it has a protective earth terminal. That terminal must be connected to earth ground through a power source equipped with a ground receptacle. Refer to the Safety Summary page at the beginning of this guide for general safety information. Before installation or operation, check the dc source and review this guide for safety warnings and instructions. Safety warnings for specific procedures are located at appropriate places in the guide.

## Options and Accessories

**Table 2-1. Options**

Option	Description
100	87–106 Vac, 47–63 Hz
220	191–233 Vac, 47–63 Hz
230	207–253 Vac, 47–63 Hz
8ZJ	Delete instrument feet option
AXS <sup>1</sup>	Rack mount kit for two side-by-side units of equal depth. Consists of: Lock-link kit (HP p/n 5061-9694) and Flange kit (HP p/n 5062-3974)
1CM <sup>1</sup>	Rack mount kit for one unit (HP p/n 5062-3972)
052	Device characterization software for current measurements and display (available for HP Model 66311B only)

<sup>1</sup>Support rails are required when rack mounting units. Use E3663A support rails for HP rack cabinets, and E3664A for non-HP rack cabinets.

**Table 2-2. Accessories**

Item	HP Part Number
HP-IB cables 1.0 meter (3.3 ft)	HP 10833A
2.0 meters (6.6 ft)	HP 10833B
4.0 meters (13.2 ft)	HP 10833C
0.5 meters (1.6 ft)	HP 10833D
RS-232 cable 9-pin F to 9-pin F, 2.5 meter, null modem/printer cable with one 9-pin M to 25-pin F adapter	HP 34398A
RS-232 adapter kit - contains the following 4 adapters 9-pin M to 25-pin M for pc or printer 9-pin M to 25-pin M for pc or printer 9-pin M to 25-pin M for modem 9-pin M to 9-pin M for modem	HP 34399A
Rack mount with slide - for two side-by-side units of different depths	5062-3996; 1494-0015
Rack mount - for two side by side units of different depths	5062-3996
Rack mount with slide - for one unit	5062-3996; 1494-0015; 5062-4022
Remote Front Panel - for viewing up to six HP 66111A/66311B units that are installed in a remote location where the front panels is not visible. Includes an ac/dc adapter for powering up to 3 remote panels	HP 14575A

## Description

The HP 66111A is a high performance dc power source that provides peak current sourcing and rapid, basic measurements in a compact, half-rack box. It is designed to simplify the testing of digital wireless communications products. Excellent voltage transient response characteristics prevent test interruptions due to triggering of low voltage phone shutdown. Fast command processing and voltage change response times maximize throughput. Measurement capability provides rapid dc voltage and current measurements. The 15 volt source and 5A peak current capability provides compatibility with a number of communications standards, including: GSM, CDMA, TDMA, PCS, DECT, TERA, PHS, NADC, PHS, and others.

The HP 66311B is a high performance dc power source that provides all of the capabilities of the HP 66111A plus fast dynamic measurement and analysis of voltage and current waveforms. Dynamic measurement and analysis of current waveforms combined with precision current measurement let you characterize cellular phone current requirements under all operating conditions.

**Table 2-3. HP 66111A/66311B Differences**

<b>Item</b>	<b>HP 66111A</b>	<b>HP 66311B</b>
Dynamic Measurement capability	not available	rms, high, low, max, min
Low range current measurement accuracy	not available	0.1% +2.5 $\mu$ A
+ High range current measurement accuracy	0.2% +9 mA	0.2% +0.5 mA
- High range current measurement accuracy	0.2% +9 mA	0.2% +1.1 mA

## Capabilities

- ◆ Output Voltage and Current control with 12-bit programming resolution.
  - 3 ampere current source capability (up to 5 amperes for 7 milliseconds)
- ◆ Extensive measurement capability:
  - dc voltage and current.
  - rms and peak voltage and current.
  - Current measurement capability up to approximately 7.0 amperes
  - 16-bit measurement resolution (low range has resolution better than 1 microampere).
  - Triggered acquisition of digitized current and voltage waveforms (HP 66311B only)
- ◆ Front panel control with 14-character vacuum fluorescent display, keypad, and rotary control for voltage and current settings.
- ◆ Built-in HP-IB and RS-232 interface programming with SCPI command language.
- ◆ Non-volatile state storage and recall with SCPI command language.
- ◆ Over-voltage, over-current, over-temperature, and RI/DFI protection features.
- ◆ Extensive selftest, status reporting, and software calibration.

## 2 - General Information

### Front Panel Controls

The front panel has both rotary (RPG) and keypad controls for setting the output voltage and current. The panel display provides digital readouts of a number of output measurements. Annunciators display the operating status of the dc source. System keys let you perform system functions such as setting the HP-IB address and recalling operating states. Front panel Function keys access the dc source function menus. Front panel Entry keys let you select and enter parameter values. Refer to chapter 5 for a complete description of the front panel controls.

### Remote Programming

---

**NOTE:** When shipped, all units are set to the SCPI programming language. The language setting is saved in non-volatile memory.

To change the programming language from SCPI to COMPatibility language, press the front panel **Address** key, use ▼ to scroll to the LANG command, press ↓ to select COMP, then press **Enter**. Refer to the chapters 6 through 8 for further information about remote programming.

---

The dc source may be remotely programmed via the HP-IB bus and/or from an RS-232 serial port. HP-IB programming is with SCPI commands (Standard Commands for Programmable Instruments), which make the dc source programs compatible with those of other HP-IB instruments. Dc source status registers allow remote monitoring of a wide variety of dc source operating conditions. A Compatibility language mode is also included to make the dc source compatible with the HP 6632A, 6633A, and 6634A Series dc power supplies (refer to appendix E). Note that the compatibility features of this unit are limited to the features that were originally available on HP 6632A, 6633A, and 6634A units.

### Output Characteristic

The dc source's output characteristic is shown in the following figure. The output of the dc source may be adjusted to any value within the boundaries shown.

The dc source is capable of providing a constant dc output of 15 volts with up to 3 amperes of current. It is capable of sourcing peak currents of up to 5 amperes -- provided the peak current pulse does not exceed 7 milliseconds, and the *average* current requirement does not exceed 3 amperes. If the unit attempts to draw current for longer than seven milliseconds, the current limit amplifier will limit the current to 3.0712 amps. The peak current capability is illustrated by the dotted line in Figure 2-1.

---

**NOTE:** To source up to 5 amperes of current for up to 7 milliseconds, **the current limit must be programmed for greater than 3 amperes (up to a maximum of 3.0712 A).**

---

The dc source can operate in either constant voltage (CV) or constant current (CC) over the rated output voltage and current. Figure 2-1 shows a single range – two quadrant capability. This means that the dc source is capable of sourcing as well as sinking current over the output voltage range from zero volts to the rated voltage. This negative current sinking capability provides fast downprogramming of the output of the dc source. It can also be used to sink current from a battery charger, thus providing battery charger test capability. The negative current is not programmable, and varies linearly from 1.2 amperes at the full rated voltage, to 2.8 amperes at zero output voltage.

**Figure 2-1. Dc Source Output Characteristic**

The operating point of the unit is determined by the voltage setting, current setting, and the load

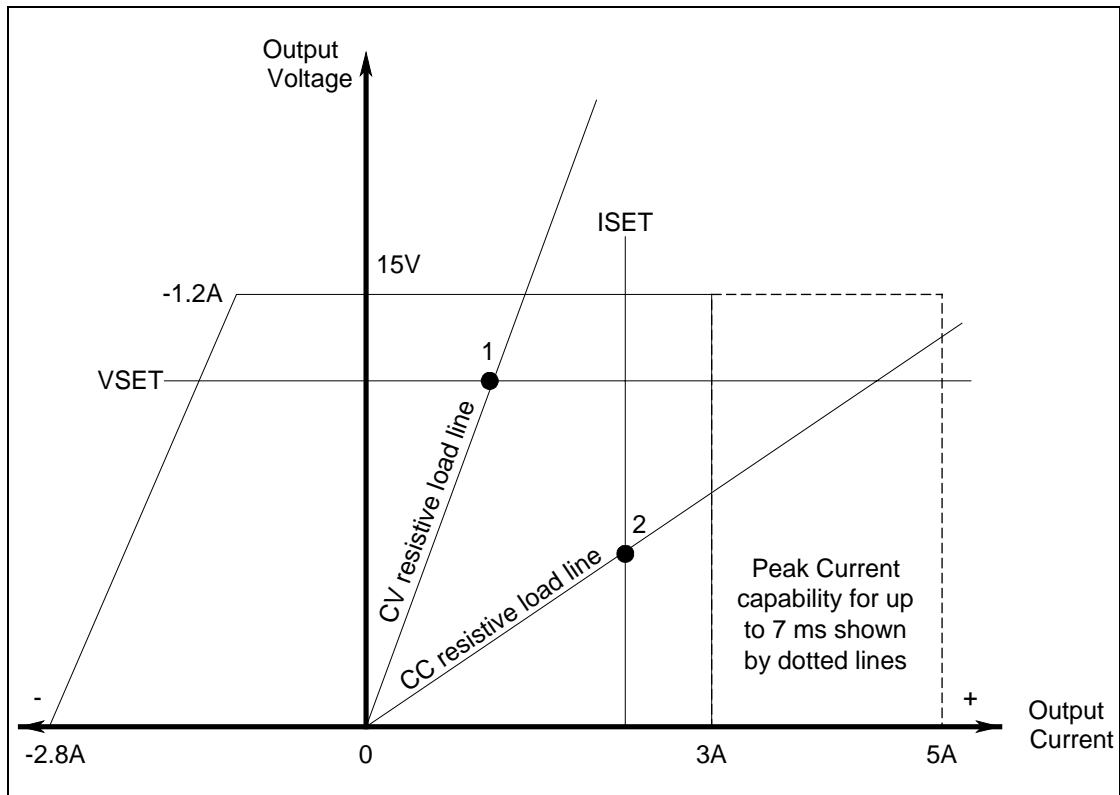

resistance. In figure 2-1, operating point 1 is defined by the load line traversing the positive operating quadrant in the constant voltage region. Operating point 2 is defined by the load line traversing the positive operating quadrant in the constant current region.

---

**NOTE:** If you attempt to operate the dc source beyond its output ratings, the output of the unit may become unregulated. This is indicated by the UNR annunciator on the front panel. The output may also become unregulated if the ac line voltage drops below the minimum rating specified in Appendix A.

---

Appendix A documents the dc source's specifications and supplemental characteristics.





## Installation

---

### Installation and Operating Checklist

#### Check the Output Compensation

**Check that the output compensation of the dc source** is appropriate for your application. Refer to “Output Compensation” in this chapter.

**High** mode provides the best transient response and can be used with phones having input capacitances from 5 to 12000  $\mu\text{F}$ . **Note** that if the last two digits on the front panel display are fluctuating when the phone is in standby, you may want to set the output compensation to Low mode.

**Low** mode is used when testing phones having input capacitances from 0 to 12000  $\mu\text{F}$ . Standard dc sources are factory-set to Low mode.

#### Check the Sense and Load Connections

**If you are remote sensing, is the sense switch on the back of the dc source in the Remote position?** Remote sensing is recommended for most applications. Push the switch out for remote sensing. Attempting to operate the unit with the switch in the out position without connecting the sense leads may result in an overvoltage or remote sense detect shutdown. Refer to “Remote Sensing” in this chapter.

**If you are remote sensing, are the + and - sense leads connected ONLY at the test fixture and within 20 inches of the phone contacts?** For best performance, the distance from sense lead termination to the phone contacts should be as short as possible. Refer to “Lead Resistance” in this chapter.

#### Check the Operating Settings and Conditions

**Are you able to communicate remotely with the dc source?** If not, check that the address setting and the programming language are set correctly. Refer to “HP-IB address” and “Language setting” in chapter 5.

**Is the Prot or Err annunciator on the front panel on?** If yes, clear the fault condition before continuing. Refer to “Clearing Protection” in chapter 5.

**Is the Overvoltage circuit shutting the unit down?** If yes, you can disable the overvoltage circuit. Refer to “Clearing Protection” in chapter 5.

**Are the front panel readings unstable?** If yes, check that the front panel sampling rate is correct. Also check the setting of the output compensation. Refer to “Front Panel Measurements” in chapter 5 and “Output Compensation” in this chapter.

#### Additional HP 66311B Operating Settings Checks

**Are you measuring dynamic output currents?** If yes, check that the current detector is set to ACDC. Refer to “Front Panel Measurements” in chapter 5.

**Are you measuring output currents under 20 mA?** If yes, check that the current range is set to LOW. Refer to “Front Panel Measurements” in chapter 5.

---

## Inspection

### Damage

When you receive your dc source, inspect it for any obvious damage that may have occurred during shipment. If there is damage, notify the shipping carrier and the nearest HP Sales and Support Office immediately. The list of HP Sales and Support Offices is at the back of this guide. Warranty information is printed in the front of this guide.

### Packaging Material

Until you have checked out the dc source, save the shipping carton and packing materials in case the unit has to be returned. If you return the dc source for service, attach a tag identifying the model number and the owner. Also include a brief description of the problem.

### Items Supplied

The following user-replaceable items are included with your dc source. Some of these items are installed in the unit.

**Table 3-1. Items Supplied**

<b>Item</b>	<b>Part Number</b>	<b>Description</b>
Power Cord	contact the nearest HP Sales and Support Office	A power cord appropriate for your location.
Digital connector	1252-1488	4-terminal digital plug that connects to the back of the unit.
Output connector	0360-2604	5-terminal plug that connects to the back of the unit.
Line Fuse	2110-0303 2110-0007	2 A slow-blow for 100/120 Vac operation 1 A slow-blow for 220/230 Vac operation
Feet	5041-8801	feet for bench mounting
User's Guide	5964-8106	Contains installation, checkout, and front panel programming information.

### Cleaning

Use a dry cloth or one slightly dampened with water to clean the external case parts. Do not attempt to clean internally.

---

**WARNING:** To prevent electric shock, unplug the unit before cleaning.

---

## Location

The outline diagram in figure 3-1 gives the dimensions of your dc source. The dc source must be installed in a location that allows sufficient space at the sides and back of the unit for adequate air circulation (see Bench Operation).

## Bench Operation

**Do not block the fan exhaust at the rear of the unit.**

A fan cools the dc source by drawing air in through the sides and exhausting it out the back. Minimum clearances for bench operation are 1 inch (25 mm) along the sides.

## Rack Mounting

The dc source can be mounted in a standard 19-inch rack panel or cabinet. Table 2-1 documents the HP part numbers for the various rack mounting options that are available for the dc source. Installation instructions are included with each rack mount option.

**NOTE:** Support rails or an instrument shelf is required when rack mounting units.

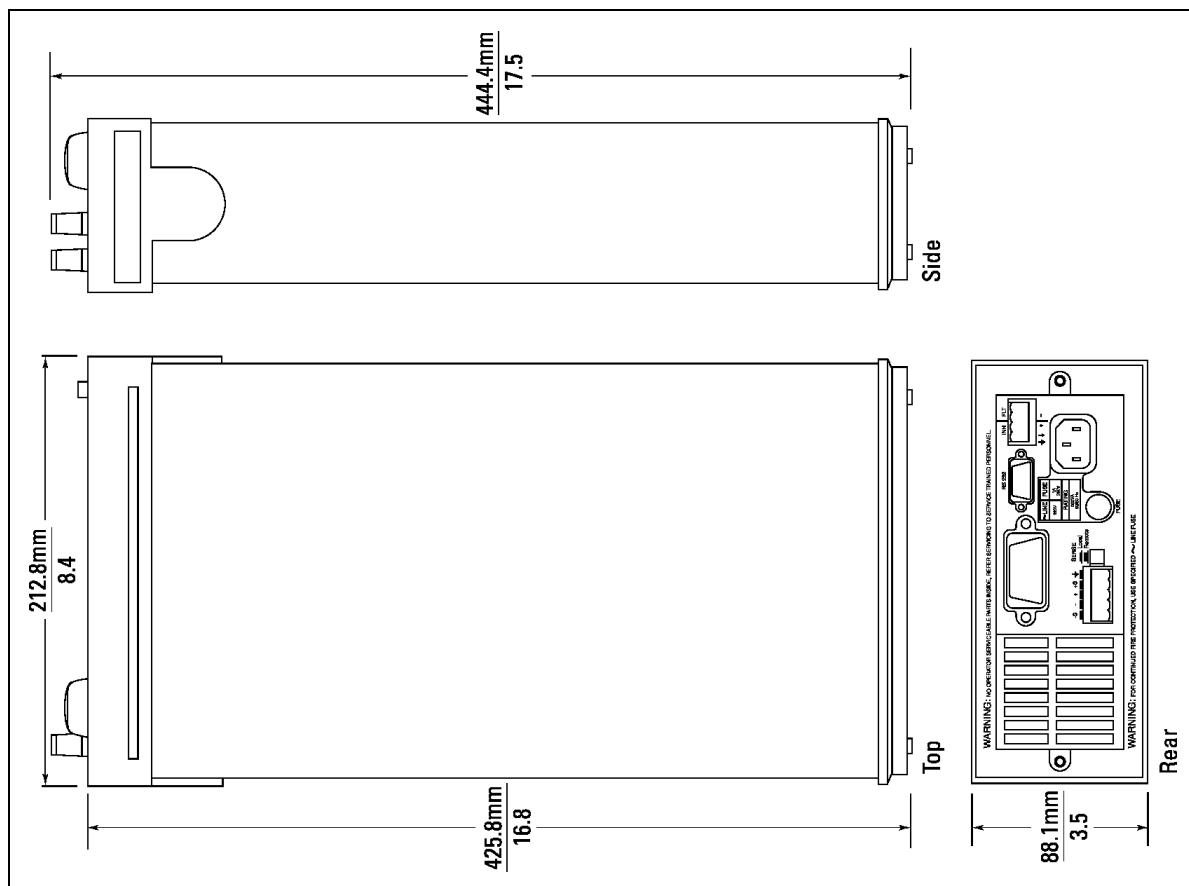

Figure 3-1. Outline Diagram

---

## Input Connections

### Connect the Power Cord

1. Unscrew the line fuse cap from the rear panel and verify that the fuse rating matches what is specified on the FUSES label on the rear panel. Reinstall the fuse. (See table 3-1 for fuse part numbers.)
2. Connect the power cord to the IEC 320 connector on the rear of the unit. If the wrong power cord was shipped with your unit, contact your nearest HP Sales and Support Office to obtain the correct cord (refer to the list at the back of this guide).

---

## Output Connections

**Turn the unit off before connecting any wires.**

The output connector has a termination for the + and – output, the + and – sense terminals, and an earth ground terminal. The 5-pin connector is removable and accepts wires sizes from AWG 22 to AWG 12. Disconnect the mating plug from the unit by pulling it straight back.

### Current Ratings

---

**Fire Hazard** To satisfy safety requirements, load wires must be large enough not to overheat when carrying the maximum short-circuit current of the dc source.

---

The following table lists the characteristics of AWG (American Wire Gage) copper wire.

**Table 3-2. Ampacity and Resistance of Stranded Copper Conductors**

AWG No.	Maximum Ampacity (in free air)	Resistance (at 20 deg. C)	
		$\Omega/m$	$\Omega/ft$
24	3.52	0.0843	0.0257
22	5.0	0.0531	0.0162
20	8.33	0.0331	0.0101
18	15.4	0.0210	0.00639
16	19.4	0.0132	0.00402
14	31.2	0.0083	0.00252
12	40	0.0052	0.00159

### Voltage Drops and Lead Resistance

To optimize the performance and transient response in your test system, please observe the following guidelines:

- ◆ Twist the load leads together and keep them short. The shorter the leads, the better the performance.
- ◆ When remote sensing, twist the sense leads together but do not bundle them in with the load leads.
- ◆ Keep the total cable length to 18 inches or less when local sensing.
- ◆ Keep the total cable length to the load to 20 ft or less when remote sensing. (Note that the unit has been tested with cable lengths of up to 40 feet.)

The load wires must also be of a diameter large enough to avoid excessive voltage drops due to the impedance of the wires. In general, if the wires are heavy enough to carry the maximum short circuit current without overheating, excessive voltage drops will not be a problem.

The maximum allowable value of load lead resistance is 4 ohms total (2 ohms per side). This may be further limited to a lower value, based on peak current loading, by the maximum allowable dc voltage drop of 8 volts total (4 volts per side) as specified for remote sense operation. To illustrate, for up to 2 amps peak, the maximum allowable resistance is 4 ohms total, resulting in a maximum voltage drop of up to 8 volts. For 4 amps peak the maximum allowable resistance is 2 ohms total, again resulting in a maximum allowable voltage drop of up to 8 volts.

In addition to keeping dc resistance low, you also need to minimize the total impedance. For higher slew rate currents (0.2 to 0.3 amps/ $\mu$ s) and long wiring lengths (10 to 20 ft.) the inductance can have as much effect as the resistance. To minimize inductance, twist the load leads. The inductance will be on the order of 0.15  $\mu$ H/ft if twisted, and 0.4  $\mu$ H/ft if untwisted. In addition to lowering the inductance, twisting the leads will reduce noise pick up. If you are using remote sense leads, connect these as a second twisted pair. Do not twist or bundle them with the load leads.

---

**NOTE:** The use of relays between the dc source and the phone also increases impedance. Low resistance relays will improve system performance.

---

---

## Remote Sensing

**Turn the unit off before connecting any wires.**

**With the Remote/Local switch in the Remote position**, the dc source regulates the output voltage at the output terminals on the back of the unit. External sense terminals are available on the **back** of the unit that allow the output voltages to be sensed at the load, compensating for impedance losses in the load wiring. Remote sensing is illustrated in figure 3-2.

---

**NOTE:** For the majority of phone applications, remote sensing is highly recommended. In many cases, remote sensing must be used to ensure stability and optimize transient response.

---

The output connector accepts wires sizes from AWG 22 to AWG 12. Disconnect the mating plug to make your wiring connections. When the sense wire connections are complete, set the Remote/Local switch on the back of the unit to Remote (switch is out).

### 3 - Installation

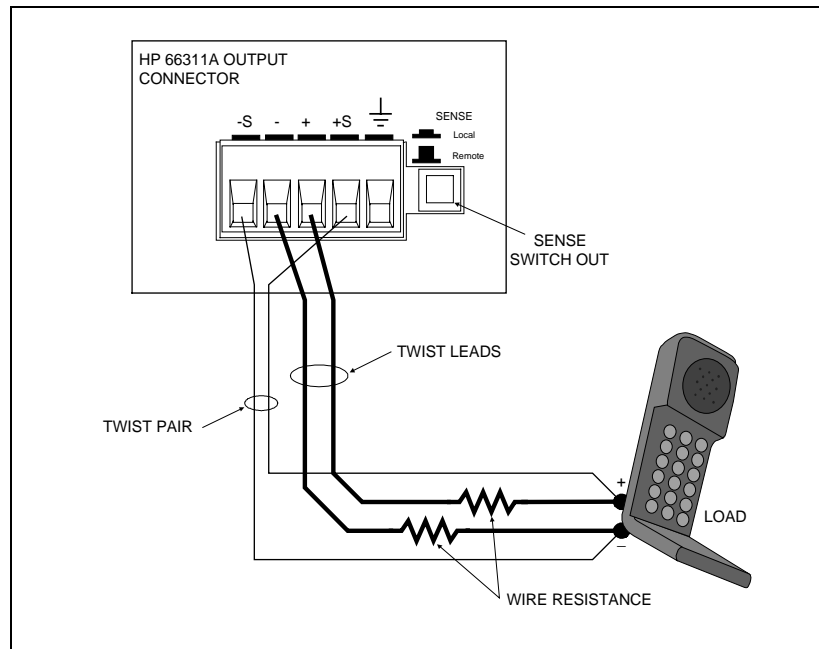

**Figure 3-2. Remote Sense Connections**

#### Remote Sense Leads

Testing has verified stable performance with the sense leads connected up to 20 inches from the phone. However, for optimum performance, connect the sense leads as close as possible to the phone under test. To minimize inductance, connect the sense leads as a separate twisted pair.

The sense leads are part of the dc source's feedback path and must be kept at a low resistance (less than several ohms) to maintain optimal performance. Connect the sense leads carefully so that they do not become open-circuited. If the sense leads are left unconnected or become open during operation, the dc source will not regulate the output voltage. See "Open Sense Lead Protection".

Connect the remote sense leads only to the remote sense connections at the output connector and at the location on the test fixture where you want to sense the output voltage. There must not be any continuity from the sense leads to earth ground or from the sense leads to the output leads other than at the test fixture. The open sense detect circuit will check for continuity in the sense leads when the output is turned.

Figure 3-3 shows how to connect remote sense leads and load leads when external disconnect relays are included in the load path.

---

**NOTE:** In this arrangement, the output of the unit should be programmed OFF *before* the relays are switched. This is because if the load leads are opened before the sense leads, the overvoltage protection circuit will trip if it is enabled.

---

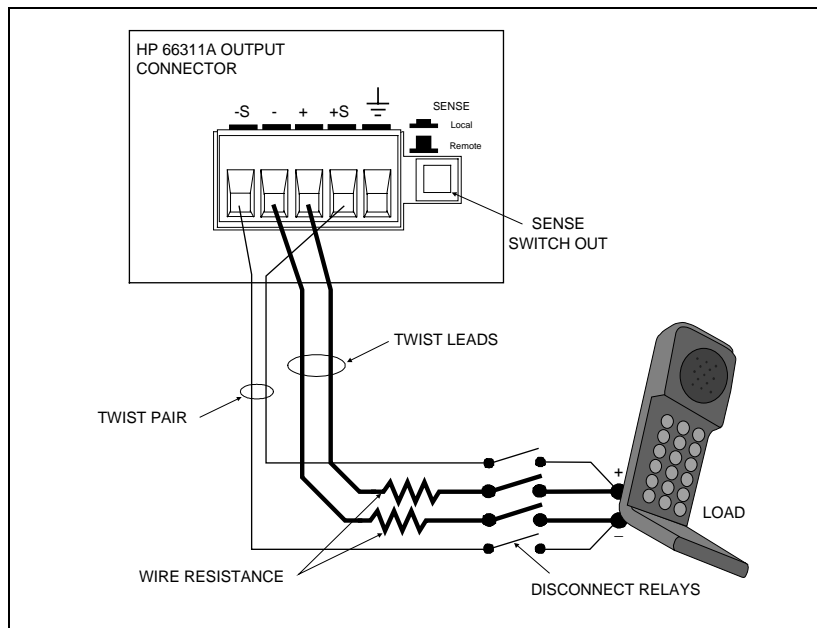

**Figure 3-3. Remote Sense Connections with External Relays**

Figure 3-4 shows how to connect remote sense leads when using a removable test fixture. Note that in this configuration, the wires in the part of the test fixture where the phone is located must be less than 20 inches in length. This is for stability as well as for the fact that the remote sense leads cannot compensate for the voltage drop in this part of the test fixture.

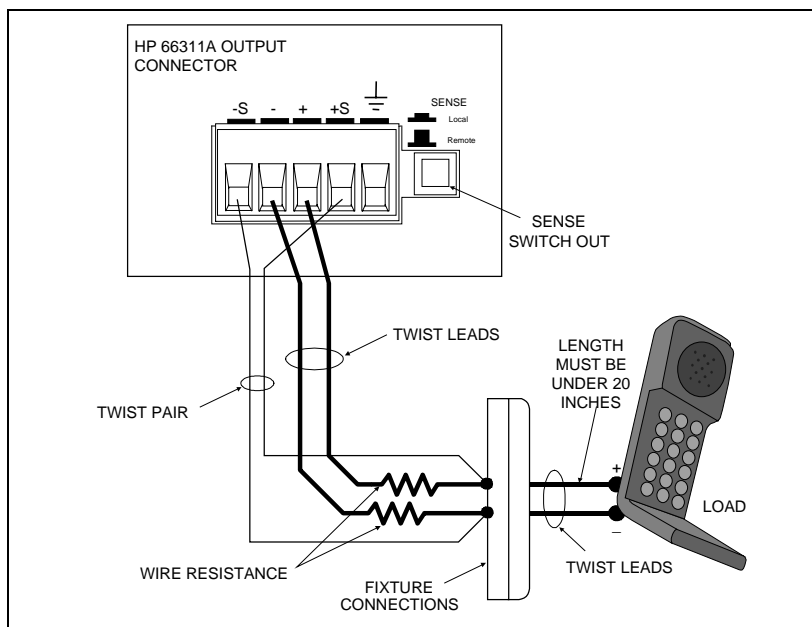

**Figure 3-4. Remote Sense Connections with Test Fixture**

### 3 - Installation

The overvoltage protection circuit senses voltage near the output terminals, not at the load. Therefore the signal sensed by the OVP circuit can be significantly higher than the actual voltage at the load. When using remote sensing, you must program the OVP trip voltage high enough to compensate for the voltage drop between the output terminals and the load. Also, if the sum of the programmed voltage and the load-lead drop exceeds the maximum voltage rating of the dc source, this may also trip the OV protection circuit. Refer to OVP considerations for more information.

### Maintaining Stability while Remote Sensing

The remote sense bandwidth and slew rate of standard dc power sources are adequate for compensating for load lead voltage drop for slow to moderate rates of load changes. However, the high pulsed current draw of digital cellular phones presents a challenge to standard dc power sources operating in remote sense mode. Their bandwidth and slew rate are not adequate for dealing with the 0.05 to 0.2 amp/ $\mu$ s slew rates imposed by these devices. A large voltage transient occurs at the load, due to the inability of the dc source to keep up with the rate of load change.

In remote sense mode, the HP 66111A/66311B effectively compensates for load lead voltage drops resulting from very high slew rate load current transitions and thus keeps the remotely sensed output voltage at a constant level. For 0.05 amp/ $\mu$ s to 0.2 amp/ $\mu$ s slew rate loading in typical test applications, the transient voltage is reduced more than an order of magnitude over that of a standard dc source.

### Open Sense Lead Protection

The dc source has built-in open sense protection circuitry that detects if a remote sense lead has opened. For battery powered devices, undetected open sense connections can cause incorrect battery charger calibration, incorrect test results due to erroneous voltage settings, and low voltage phone shutdown due to a large transient voltage drop.

If the open sense lead protection circuit detects a resistance greater than 100K ohms in the sense leads, the **Prot** annunciator on the front panel turns on and the output turns off. Bit 5 in the Questionable Status Registers is also set (see chapter 7 under "Programming the Status Registers"). On the front panel, press the **Prot** key, and one of the following error messages will be reported on the front panel:

<u>Message</u>	<u>Description</u>
+ sense open	Positive sense lead is open
- sense open	Negative sense lead is open
+/- sense open	Both positive and negative sense leads are open
sense open	Incorrect resistance reading on the sense leads This may be caused by an external power source paralleled with the output, or in rare instances, by the voltage being out of calibration.

The sense leads are checked every time the output state transitions from disabled to enabled. This can be done using the Output On/Off key or the Output On command. If a sense lead opens while the output is enabled, this will not be detected by the open sense circuit until the output transitions from disabled to enabled. Meanwhile, the output voltage will either increase or decrease, depending on which one of the sense leads is open. Figure 3-5 illustrates the actual output voltage change that occurs with zero output current if a sense lead opens. Turning the output Off, then On, when this occurs will cause the unit to check the sense leads and determine if a sense lead is indeed open.



The default setting for the open sense lead protection circuit is disabled or **OFF**. This is because applications that apply an external voltage to the output or that use external disconnect relays may interfere with the operation of the open sense detect circuit. If you are using external voltages or relays, you can enable the open sense detect at the beginning of the test procedure. Make sure that the external voltage is disabled and that any relays are in the closed position. Perform the remote sense check by cycling the output off, then on. Then disable the open sense detect circuit and continue using the unit.

**To enable open sense lead detection** from the front panel, press the **Output** key, use **p** to scroll to **SENS:PROT**, press **↵** to select **ON**, then press **Enter**. To have the unit turn on with open sense detection enabled, save this state in location 0 and set the power-on state to RCL 0.

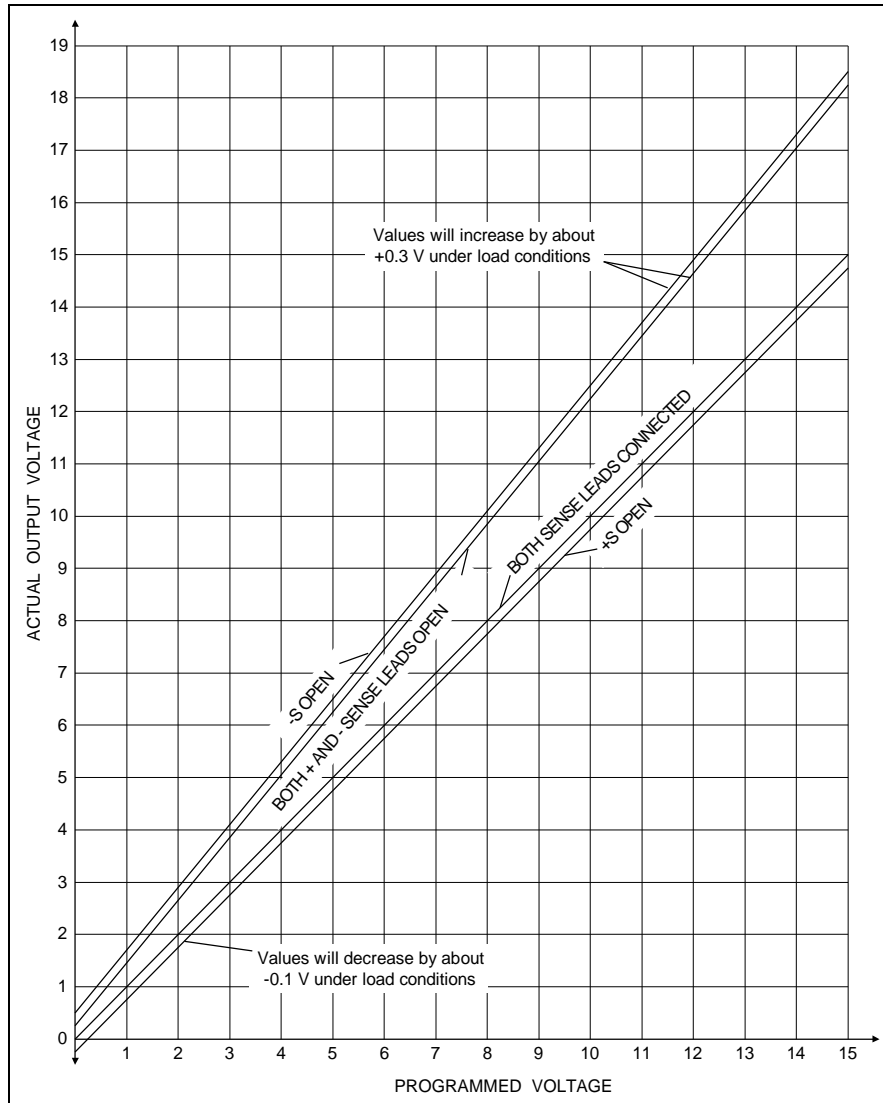

**Figure 3-5. Output Voltage vs. Programmed Voltage with Open Sense Condition**

## Output Compensation (High Mode/Low Mode)

High bandwidth performance and stability are achieved by using a software-switchable output compensation circuit. This compensation circuit sets the remote sensing response of the dc source for the capacitance of the cellular phones. The compensation function is set using either the front panel TYPE:CAP command located in the Output menu (see chapter 5), or the OUTput:TYPE[:CAPacitance] SCPI command as explained in chapter 8. The circuit covers the following capacitance ranges:

- ◆ Low Mode: 0 to 12,000  $\mu\text{F}$
- ◆ High Mode: 5  $\mu\text{F}$  to 12,000  $\mu\text{F}$

The HP 66311B is shipped from the factory with the output compensation set to Low Mode. If you do not know the input capacitance of the phone that you are testing, leave the input capacitance set to Low Mode initially. This is because in Low Mode, the output of the dc source will be stable when testing cellular phones that have virtually any input capacitance (from 0  $\mu\text{F}$  to 12,000  $\mu\text{F}$ ). Low mode however, has a slower transient response (see appendix A).

The High Mode output compensation setting provides faster transient response performance for most phones. (Most phones have input capacitances greater than 5  $\mu\text{F}$ .) In High Mode however, the operation of the dc source may be momentarily unstable with phones that have input capacitances *less* than 5  $\mu\text{F}$ .

If you are testing phones in High Mode and want to determine if the input capacitance of your phone is less than 5  $\mu\text{F}$ , perform the following test.

---

**NOTE:** It is important that this test is done with the dc source installed in the test system where it will be used, since system stability is also dependent on wiring and the phone impedance.

---

1. Connect the phone to the dc source and place it in standby mode.
2. Check the last *two* digits of the voltage reading on the front panel of the dc source.
3. If the last two digits are fluctuating, it is an indication that the phone capacitance may be less than 5  $\mu\text{F}$  and the dc source is momentarily unstable.
4. Place the output compensation of the dc source in Low Mode.
5. If the last two digits of the voltage reading are now stable, your phone has an input capacitance less than 5  $\mu\text{F}$ .

---

## Local Sensing

Remote sensing is preferred when connecting the output of the dc source to the load. However, you may also connect the output to the load without remote sensing provided that you observe the following:

- ◆ Keep load leads as short as possible. Load leads cannot exceed 18 inches (per side) when local sensing.
- ◆ Bundle or twist the leads tightly together to minimize inductance.

- ◆ Set the Sense switch on the back of the unit to **Local** by pushing it in.

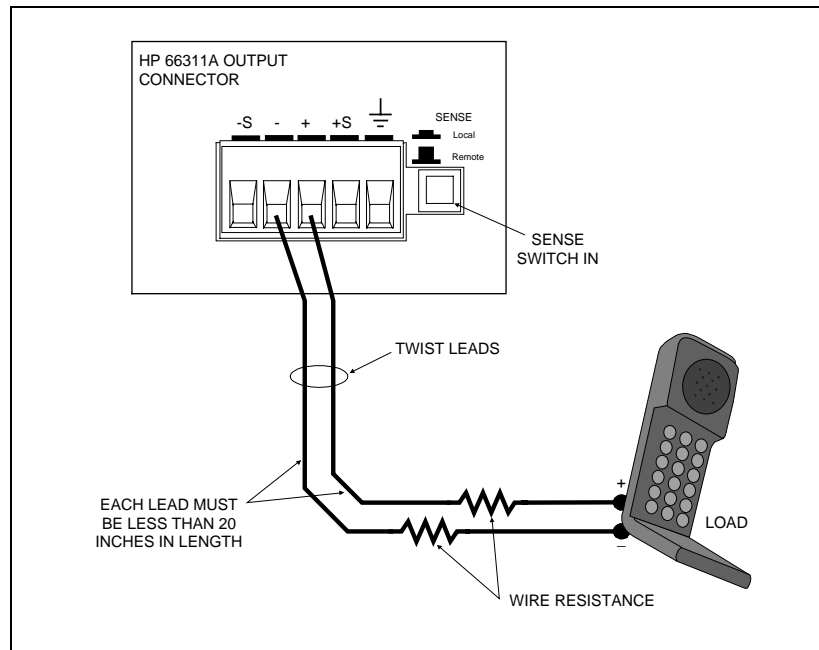

Figure 3-6. Local Sensing

---

## OVP Considerations

---

**CAUTION:** Disabling the OVP protection circuit may cause excessive output voltages, such as can occur if remote sense leads are shorted, to damage the equipment under test.

---

The dc source is shipped from the factory with its overvoltage protection circuit enabled. You can disable the OVP circuit using either the front panel VOLT PROT command located in the OV menu, or the VOLTage:PROTection:STATe SCPI command as explained in chapter 8.

The OVP circuit contains a crowbar SCR, which effectively shorts the output of the dc source whenever the OVP trips. However, if an external current source such as a battery is connected across the output and the OVP is inadvertently triggered, the SCR will continuously sink a large current from the battery, possibly damaging the dc source.

To avoid this, either disable the OVP circuit or program it to its maximum value to prevent it from inadvertently tripping. Additionally, you can connect an external protection diode in series with the output of the dc source. Connect the anode of the diode to the + output terminal.

The OVP circuit's SCR crowbar has also been designed to discharge capacitances up to a specific limit, which is 50,000  $\mu\text{F}$ . If your load capacitance approaches this limit, it is recommended that you do not intentionally trip the OVP and discharge the capacitance through the SCR as part of your normal testing procedure, as this may lead to long-term failure of some components.

## External Protection Connections

This rear panel connector, has a fault output port and an inhibit input port. The fault (FLT) output, also referred to as the DFI (discrete fault indicator) signal in the front panel and SCPI commands, is an open collector circuit that pulls the positive output low with respect to the negative (chassis-referenced) common. The high impedance inhibit (INH) input, also referred to as the RI (remote inhibit) signal in the front panel and SCPI commands, is used to shut down the dc source output whenever the INH + is pulled low with respect to the INH (chassis-referenced) common.

The connector accepts wires sizes from AWG 22 to AWG 12. Disconnect the mating plug to make your wire connections.

**NOTE:** It is good engineering practice to twist and shield all signal wires to and from the digital connectors. If shielded wire is used, connect only one end of the shield to chassis ground to prevent ground loops.

Figure 3-7 shows how you can connect the FLT/INH circuits of the dc source.

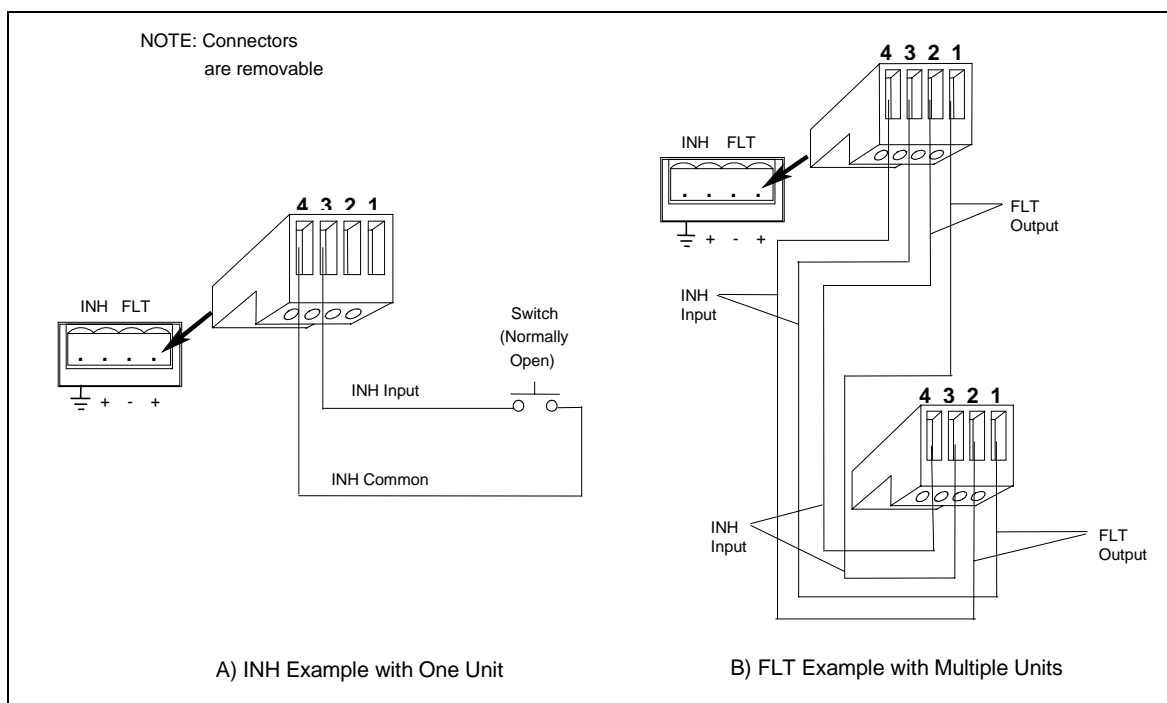

**Figure 3-7. FLT/INH Examples**

**In example A**, the INH input connects to a switch that shorts the Inhibit pin (+) to common whenever it is necessary to disable output of the unit. This activates the remote inhibit (RI) circuit, which turns off the dc output. The front panel Prot annunciator comes on and the RI bit is set in the Questionable Status Event register. To re-enable the unit, first open the connection between pins INH + and common and then clear the protection circuit. This can be done either from the front panel or over the HP-IB/RS-232.

**In example B**, the FLT output of one unit is connected to the INH input of another unit. A fault condition in one of the units will disable all of them without intervention either by the controller or external circuitry. The controller can be made aware of the fault via a service request (SRQ) generated by the Questionable Status summary bit. Note that the FLT output can also be used to drive an external relay circuit or signal other devices whenever a user-definable fault occurs.

## Digital I/O Connections

As shown in Table 3-3 and Figure 3-8, the FLT/INH connector can also be configured as a digital I/O port. Information on programming the digital I/O port is found in chapter 5 and under [SOURCE:]DIGital:DATA and [SOURCE:]DIGital:FUNCTion commands in chapter 8. The electrical characteristics of the digital connector are described in appendix A.

**Table 3-3. FLT/INH DIGITAL I/O Connector**

PIN	FAULT/INHIBIT	DIGITAL I/O
1	FLT Output	Output 0
2	FLT Common	Output 1
3	INH Input	Input/Output 2
4	INH Common	Common

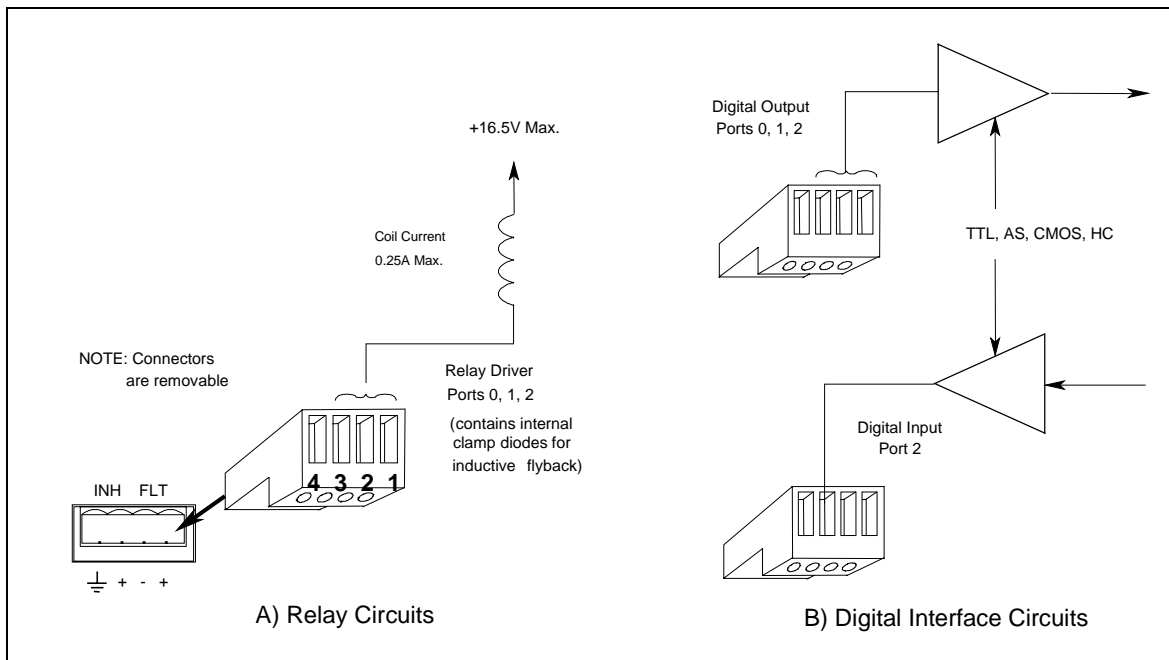

**Figure 3-8. Digital I/O Examples**

## Controller Connections

The dc source can be controlled either through an HP-IB or an RS-232 interface.

### HP-IB Interface

Each dc source has its own HP-IB bus address, which can be set using the front panel **Address** key as described in chapter 5. HP-IB address data is stored in non-volatile memory. The dc source is shipped with its HP-IB address set to 5.

Dc sources may be connected to the HP-IB interface in series configuration, star configuration, or a combination of the two, provided the following rules are observed:

- ◆ The total number of devices including the controller is no more than 15.
- ◆ The total length of all cables used is no more than 2 meters times the number of devices connected together, up to a maximum of 20 meters. (Refer to table 2-2 for a list of HP-IB cables available from Hewlett-Packard.)
- ◆ Do not stack more than three connector blocks together on any HP-IB connector.
- ◆ Make sure all connectors are fully seated and the lock screws are firmly finger-tightened.

### RS-232 Interface

The dc source has an RS-232 programming interface, which is activated by commands located in the front panel **Address** menu. All SCPI and COMPAtibility commands are available through RS-232 programming. When the RS-232 interface is selected, the HP-IB interface is disabled.

The RS-232 connector is a DB-9, male connector. Adapters are available to connect the dc source to any computer or terminal with a properly configured DB-25 connector (see Table 2-2).

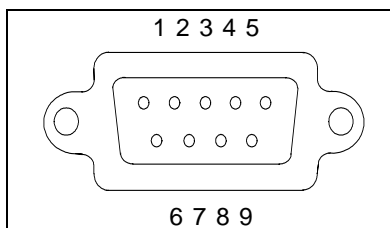

**Figure 3-9. RS-232 Connector**

Pin	Input/Output	Description
1	-	no connection
2	Input	Receive Data (RxD)
3	Output	Transmit Data (TxD)
4	Output	Data Terminal Ready (DTR)
5	Common	Signal ground
6	Input	Data Set Ready (DSR)
7	Output	Request to Send (RQS)
8	Input	Clear to Send (CTS)
9	-	no connection

## Turn-On Checkout

---

### Checkout Procedure

Successful tests in this chapter provide a high degree of confidence that the unit is operating properly. For verification tests, see appendix B. Complete performance tests are given in the Service Guide.

---

**NOTE:** To perform the checkout procedure, you will need a wire for shorting the output terminals together.

---

The following procedure assumes that the unit turns on in the factory-default state. If you need more information about the factory default state, refer to the \*RST command in chapter 8. Note that the values shown in the Display column may not exactly match the values that appear on the front panel of your unit.

If you have not already done so, connect the power cord to the unit and plug it in.

Procedure	Display	Explanation
1. Turn the unit on. The dc source undergoes a self-test when you first turn it on.	***** ADDRESS 5 0.004V .0006A	During selftest, all display segments are briefly lit, followed by the HP-IB Address.  The display then goes into meter mode with the Dis annunciator on, and all others off. In Meter mode the *****V digits indicate the output voltage and the *****A digits indicate the output current. The flashing digit on the display indicates the digit that will be affected if changes are made to the displayed values using the rotary control or the ↑ and ↓ keys. <i>You will only see the changes if the output is ON.</i>

---

**NOTE:** Press the Meter key to exit a menu at any time and return to meter mode. If the Err annunciator on the display is on, press the **Shift** key followed by the **Error** key to see the error number. See table 4-1 at the end of this chapter.

---

2. Check that the dc source fan is on		You should be able to hear the fan and feel the air coming from the back of the unit.
3. Press <b>Voltage, Enter Number, &lt;15&gt;, Enter</b>	VOLT 0.000 VOLT 15	Programs the output to 15 volts. After the value is entered, the display returns to Meter mode. Because the output has not been enabled, the meter still indicates approximately 0 volts.
4. Press <b>Output On/Off</b>	15.003V 0.0006A	Turns the output on. The <b>Dis</b> annunciator should be off and <b>CV</b> should be on.
5. Press <b>Shift, OV</b>	VOLT:PROT 22.00	Display shows the overvoltage protection trip voltage for your unit.

#### 4 - Turn-On Checkout

	<b>Procedure</b>	<b>Display</b>	<b>Explanation</b>
6.	Press <b>Enter Number, 8, Enter</b>	VOLT:PROT 8	Programs the OVP to 8 volts, which is less than the previously set output voltage.
		0.449V 0.145A	Because the OVP voltage entered was less than the output voltage, the OVP circuit tripped. The output dropped to zero, <b>CV</b> turned off, and <b>Prot</b> turned on.
7.	Press <b>Shift, OV, Enter Number, &lt;22&gt;, Enter</b>	VOLT:PROT <22>	Programs the OVP to a value greater than the output voltage setting of the unit. This prevents the OV circuit from tripping again when the protection condition is cleared.
8.	Press <b>Shift, Prot Clear</b>	<15.003>V 0.0034A	Clears the protection condition, thus restoring the output of the unit. <b>Prot</b> turns off and <b>CV</b> turns on.
9.	Press <b>Output on/off</b>		Turn the output off.
10.	Connect a jumper wire across the + and - output terminals.		Shorts the output of the unit.
11.	Press <b>Output on/off</b> .	0.0005V <0.3071>A	The <b>CC</b> annunciator is on, indicating that the unit is in constant current mode. The unit is sourcing output current at 10% of the maximum rating (the default output current limit setting).
12.	Press <b>Current, Enter Number, &lt;3&gt;, Enter</b> .	0.0452V <2.998>A	Programs the output current to 3 amperes.
13.	Press <b>Shift, OCP</b>	0.0005V 0.0003A	You enabled the overcurrent protection circuit. The circuit then tripped because the unit was operating in constant current mode. The <b>CC</b> annunciator turns off and the <b>OCP</b> and <b>Prot</b> annunciators come on.
14.	Press <b>Shift, OCP</b>	0.0005V 0.0003A	You have disabled the overcurrent protection circuit. The <b>OCP</b> annunciator turns off.
15.	Press <b>Shift, Prot Clear</b>	0.0452V <2.998>A	Restores the output. The <b>Prot</b> annunciator turns off. <b>CC</b> is on.
16.	Turn the unit off and remove the shorting wire from the output terminals.		The next time the unit turns on it will be restored to the *RST or factory default state.



## In Case of Trouble

Dc source failure may occur during power-on selftest or during operation. In either case, the display may show an error message that indicates the reason for the failure.

### Selftest Error Messages

Pressing the **Shift, Error** keys will show the error number. Selftest error messages appear as: ERROR <n> where "n" is a number listed in the following table. If this occurs, turn the power off and then back on to see if the error persists. If the error message persists, the dc source requires service.

**Table 4-1. Power-On Selftest Errors**

<b>Error No.</b>	<b>Failed Test</b>
Error 0	No error
Error 1	Non-volatile RAM RD0 section checksum failed
Error 2	Non-volatile RAM CONFIG section checksum failed
Error 3	Non-volatile RAM CAL section checksum failed
Error 4	Non-volatile RAM STATE section checksum failed
Error 5	Non-volatile RST section checksum failed
Error 10	RAM selftest
Error 11 to 14	VDAC/IDAC selftest 1 to 4
Error 15	OVDAC selftest
Error 80	Digital I/O selftest error

### Runtime Error Messages

Appendix C lists other error messages that may appear at runtime. Some of these messages will also appear on the front panel when the Prot key is pressed. To clear the error, you must remove the condition that caused the error and then press the Prot Clear key.

**Table 4-2. Runtime Error Messages**

<b>Error</b>	<b>Description</b>
Overvoltage	an overvoltage condition has occurred
Overcurrent	an overcurrent condition has occurred
Overtemperature	an overtemperature condition has occurred
Remote inhibit	a remote inhibit signal has been applied to the RI input
+ sense open	positive sense lead is open
- sense open	positive sense lead is open
+/- sense open	positive and negative sense lead is open
sense open	incorrect voltage reading on the sense leads, the unit may need to be recalibrated

If the front panel display shows **OVLD**, this indicates that the output voltage or current is beyond the range of the meter readback circuit. If this is the case, check that the setting of the output compensation is correct for the phone you are testing. If the front panel display indicates **-- -- -- -- --**, an HP-IB measurement is in progress.

## 4 - Turn-On Checkout

### Line Fuse

If the dc source appears "dead" with a blank display and the fan not running, check your power source to be certain line voltage is being supplied to the dc source. If the power source is normal, the fuse may be defective.

1. Turn off the front panel power switch and unplug the power cord.
2. Remove the fuse from the rear panel.
3. If the fuse is defective, replace it with a fuse of the same type (see Input Connections in chapter 3).
4. Turn on the dc source and check the operation.

---

**NOTE:** If the dc source has a defective fuse, replace it only once. If it fails again, the dc source requires service.

---

## Front panel Operation

### Introduction

Here is what you will find in this chapter:

- ◆ a complete description of the front panel controls
- ◆ front panel programming examples

**NOTE:** The dc source must be in set to Local mode to use the front panel controls. Press the **Local** key on the front panel to put the unit in local mode.

### Front Panel Description

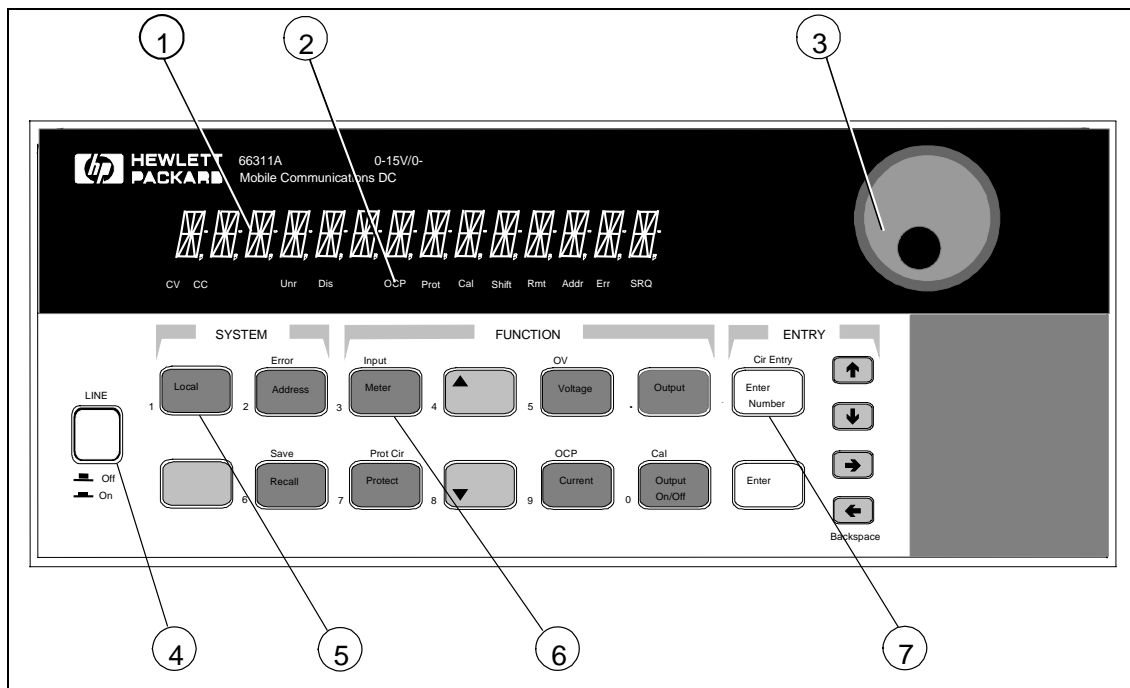

Figure 5-1. Front Panel, Overall View

## 5 – Front Panel Operation

<b>∅ Display</b>	14-character vacuum fluorescent display for showing output measurements and programmed values.
<b>κ Annunciators</b>	Annunciators light to indicate operating modes and status conditions: <b>CV</b> The dc source output is in constant-voltage mode. <b>CC</b> The dc source output is in constant-current mode. <b>Unr</b> The dc source output is in an unregulated state. <b>Dis</b> The dc source output is disabled (off). <b>OCP</b> The overcurrent protection state is enabled. <b>Prot</b> One of the dc source's output protection features is activated. <b>Cal</b> The dc source is in calibration mode. <b>Shift</b> The Shift key is pressed to access an alternate key function. <b>Rmt</b> The selected interface (HP-IB or RS-232) is in a remote state. <b>Addr</b> The interface is addressed to talk or to listen. <b>Err</b> There is a message in the SCPI error queue. <b>SRQ</b> The interface is requesting service from the controller.
<b>λ Rotary Control</b>	The rotary control lets you set the output voltage or current as well as menu parameters. Press <b>←</b> and <b>→</b> to select the resolution, then adjust the value with the knob.
<b>μ Line</b>	This turns the dc source on or off.
<b>ν System Keys</b>	The system keys let you: Return to Local mode (front panel control) Set the dc source HP-IB address Selects the remote programming interface Set the RS-232 interface communication baud rate and parity bit Display SCPI error codes and clear the error queue Save and recall up to 4 instrument operating configurations Select the programming language Enable/disable the remote front panel interface
<b>ο Function Keys</b>	Function access command menus that let you: Enable or disable the output Select metering functions Program output voltage and current Display the protection status state Set and clear protection functions Set the output state at power-on Calibrate the dc source Select the output compensation <b>▲</b> and <b>▼</b> scroll through the front panel menu commands
<b>π Entry Keys</b>	Entry keys let you: Enter programming values Increment or decrement programming values <b>↑</b> and <b>↓</b> select the front panel menu parameters

## System Keys

Refer to the examples later in this chapter for more details on the use of these keys.

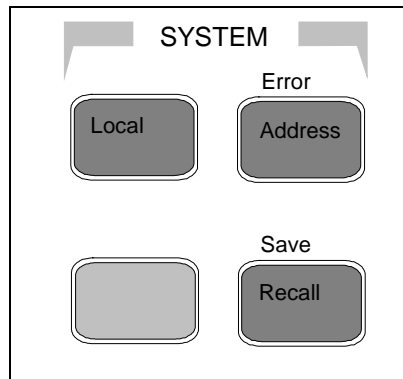

Figure 5-2. System Keys

This is the blue, unlabeled key, which is also shown as  in this guide. Pressing this key accesses the alternate or shifted function of a key (such as **ERROR**). Release the key after you press it. The **Shift** annunciator is lit, indicating that the shifted keys are active.

Press to change the dc source's selected interface from remote operation to local (front panel) operation. Pressing the key will have no effect if the interface state is already Local, Local-with-Lockout, or Remote-with-Lockout.

Press to access the system address menu. This menu lets you configure the dc source's interface. All Address menu entries are stored in non-volatile memory.

<b>Display</b>	<b>Command Function</b>
ADDRESS <value>	Sets the HP-IB Address
INTF <char>	Selects an interface (HPIB or RS232)
BAUDRATE<char>	Selects baud rate (300, 600, 1200, 2400, 4800, 9600)
PARITY <char>	Message parity (NONE, EVEN, ODD, MARK, SPACE)
FLOW <char>	Flow control (XON-XOFF, RTS-CTS, DTR-DSR, NONE)
LANG <char>	Selects language (SCPI or COMP)
REMOTE FP <char>	Enable/disable HP 14575A front panel interface (ON or OFF)

value = a numeric value

char = a character string parameter

Use  and  to scroll through the command list.

Use  and  to scroll through the parameter list.

Press to place the dc source into a previously stored state. You can recall up to 4 previously stored states (0 through 3).

Press to display the system error codes stored in the SCPI error queue. This action also clears the queue. If there is no error in the queue, 0 is displayed.

Press to store an existing dc source state in non-volatile memory. The parameters saved are listed under \*SAV as described in chapter 8. You can save up to 4 states (0 through 3).

## Function Keys

Refer to the examples later in this chapter for more details on the use of these keys.

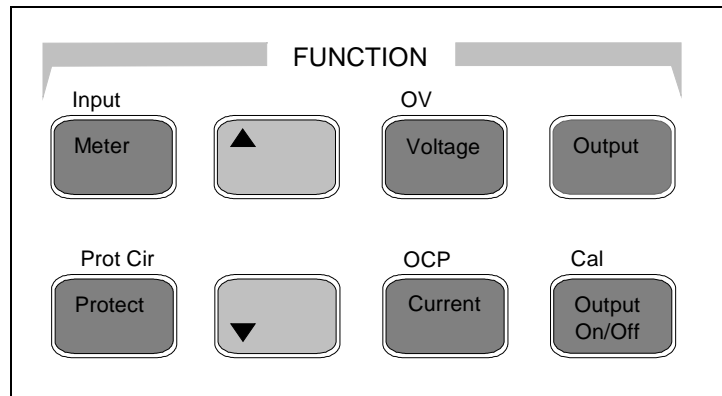

Figure 5-3. Function Keys

### Immediate Action Keys

Immediate action keys immediately execute their corresponding function when pressed. Other function keys have commands underneath them that are accessed when the key is pressed.

Output  
On/Off

This key toggles the output of the dc source between the on and off states. It immediately executes its function as soon as you press it. When off, the dc source output is disabled and the **Dis** annunciator is on.

Shift Prot Clr

Press this key to reset the protection circuit and allow the unit to return to its last programmed state. The condition that caused the protection circuit to become active must be removed prior to pressing this key, or the unit will shut down again and display the **Prot** annunciator again.

Shift OCP

Press this key to toggle between OCP enabled and disabled. If OCP is enabled the output will become disabled if the output mode changes from CV to CC mode. The OCP annunciator indicates the state of OCP.

### Scrolling Keys

Scrolling keys let you move through the commands in the presently selected function menu.

▲ ▼

Press ▼ to bring up the next command in the list. Press ▲ to go back to the previous command in the list. Function menus are circular; you can return to the starting position by continuously pressing either key. The following example shows the commands in the Input function menu:

▼ CURR:RANGE <char>  
▼ CURR:DET <char>

## Metering Keys

Metering keys control the metering functions of the dc source. As set from the factory, all front panel measurements are calculated from a total of 2048 readings taken at a 46.8 microsecond sampling rate. Therefore, the factory default acquisition time for a single front panel measurement is about 100 milliseconds. Refer to “Making Front Panel Measurements” for more information about changing the front panel sampling rate and the number of measurement points.

**NOTE:** The front panel sample rate and data point settings are separate and independent of the sample rate and data point settings that are programmed over the HP-IB interface. When an HP-IB measurement is in progress, the front panel display temporarily indicates ---. Front panel measurements resume when the HP-IB measurement completes. HP-IB measurements are discussed in chapter 7.

**Meter** Press this key to access the meter menu list. Also use this key to exit a menu at any time and return to meter mode.

Display	Measurement
<reading>V <reading>A	Measures output dc voltage and current
<reading>V MAX	Measures peak output voltage <sup>1</sup>
<reading>V MIN	Measures minimum output voltage <sup>1</sup>
<reading>V HIGH	Measures the high level of a voltage pulse waveform <sup>1</sup>
<reading>V LOW	Measures the low level of a voltage pulse waveform <sup>1</sup>
<reading>V RMS	Measures rms voltage <sup>1</sup>
<reading>A MAX	Measures peak output current <sup>1</sup>
<reading>A MIN	Measures minimum output current <sup>1</sup>
<reading>A HIGH	Measures the high level of a current pulse waveform <sup>1</sup>
<reading>A LOW	Measures the low level of a current pulse waveform <sup>1</sup>
<reading>A RMS	Measures rms current <sup>1</sup>

**Shift** **Input** Press this key to access the following metering functions.

Display	Command Function
CURR:RANGE <char>	Select current range (AUTO, LOW or HIGH) <sup>1</sup>
CURR:DET <char>	Select current measurement bandwidth (ACDC or DC) <sup>1</sup>
TINT <value>	Sets the front panel measurement interval in <i>seconds</i> (15.6 $\mu$ s to 1 second)
POINTS <char>	Sets the number of points in the front panel measurement buffer ( 1, 2, 4, 8, 16, 32, 64, 128, 256, 512, 1024, 2048)



### Notes:



<sup>1</sup>Only available on HP Model 66311B



reading = the returned measurement

value = a numeric value

char = a character string parameter

Use  and  to scroll through the menu commands.

Use  and  to scroll through the menu parameters.

Use  and  to select a digit in a numeric entry field.

## 5 – Front Panel Operation

### Output Control Keys

Output control keys control the output functions of the dc source.

**Voltage**

Press this key to access the voltage menu.

<b>Display</b>	<b>Command Function</b>
----------------	-------------------------

VOLT <value>	Sets the output voltage
--------------	-------------------------

**Current**

Press this key to access the current menu.

<b>Display</b>	<b>Command Function</b>
----------------	-------------------------

CURR <value>	Sets the output current
--------------	-------------------------

**Output**

Press this key to access the output menu list.

<b>Display</b>	<b>Command Function</b>
----------------	-------------------------

*RST	Places the dc source in the factory-default state
------	---

PON:STATE <char>	Select the power-on state command (RST or RCL0) <sup>1</sup>
------------------	--

RI <char>	Sets the remote inhibit mode (LATCHING, LIVE, or OFF) <sup>1</sup>
-----------	--

DFI <char>	Sets the discrete fault indicator state (ON or OFF)
------------	---

DFI:SOUR <char>	Selects the DFI source (QUES, OPER, ESB, RQS, or OFF) <sup>2</sup>
-----------------	--

PORT <char>	Sets the output port functions (RIDFI or DIGIO) <sup>1</sup>
-------------	--

DIGIO <char>	Sets and reads the I/O port value (0 through 7)
--------------	---

PROT:DLY <value>	Sets the output protection delay in seconds
------------------	---

TYPE:CAP <char>	Sets the output compensation (HIGH or LOW) <sup>1</sup>
-----------------	---

**Protect**

Press this key to display protection status.

<b>Display</b>	<b>Command Function</b>
----------------	-------------------------

OVER CURRENT	Status of the protection features (example shows overcurrent)
--------------	---

NO FAULT	Status of the protection features (example shows none tripped)
----------	--

**Shift**

**OV**

Press this key to access the overvoltage protection menu.

<b>Display</b>	<b>Command Function</b>
----------------	-------------------------

PROT:STAT <char>	Enables or disables overvoltage protection (ON or OFF)
------------------	--

PROT:LEV <value>	Sets the overvoltage protection level
------------------	---------------------------------------

**Shift**

**Cal**

This key accesses the calibration menu (Refer to Appendix B for details).



#### Notes:



<sup>1</sup>These parameters are stored in non-volatile memory



<sup>2</sup>These status summary bits are explained in chapter 7

value = a numeric value

char = a character string parameter

Use  and  to scroll through the menu commands.

Use  and  to scroll through the menu parameters.

Use  and  to select a digit in a numeric entry field.



## Entry Keys

Refer to the examples later in this chapter for more details on the use of these keys.

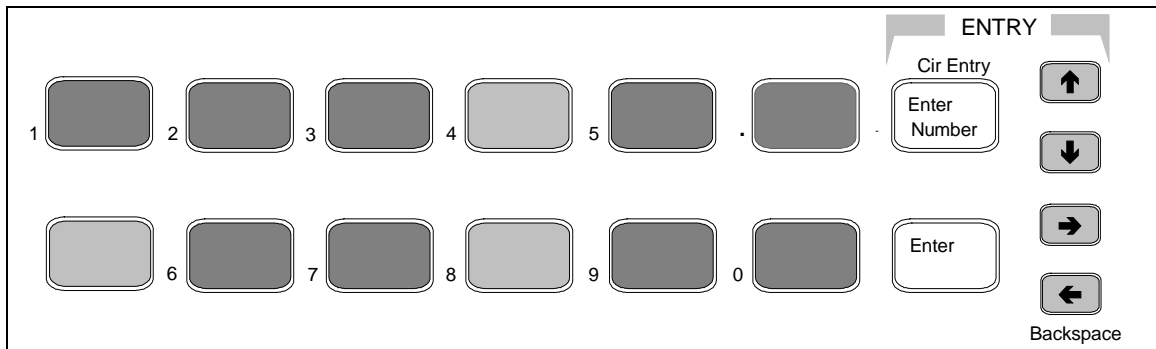

**Figure 5-4. Entry Keys**



These keys let you scroll through choices in a **parameter** list that apply to a specific command. Parameter lists are circular; you can return to the starting position by continuously pressing either key. If the command has a numeric range, these keys increment or decrement the existing value. In meter mode, these keys can be used to adjust the magnitude of the output voltage or current. Only the flashing digit is changed by these keys. Use the ← and → keys to move the flashing digit.



These keys move the flashing digit in a numeric entry field to the right or left. This lets you increment or decrement a specific digit in the entry field using the ↑ and ↓ keys or the RPG knob.

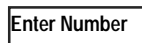

Used only to access a third level key function - the numeric entry keys. These third level function keys are labeled in green.

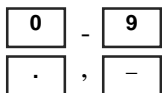

**0** through **9** are used for entering numeric values. **.** is the decimal point. **-** is the minus sign. For example, to enter 33.6 press: **Enter Number, 3, 3, ., 6, Enter.**

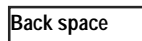

The backspace key deletes the last digit entered from the keypad. This key lets you correct one or more wrong digits before they are entered.

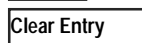

This key aborts a keypad entry by clearing the value. This key is convenient for correcting a wrong value or aborting a value entry. The display then returns to the previously set function.



This key executes the entered value or parameter of the presently accessed command. Until you press this key, the parameters you enter with the other Entry keys are displayed but not entered into the dc source. Before pressing **Enter**, you can change or abort anything previously entered into the display. After **Enter** is pressed, the dc source returns to Meter mode.

---

## Examples of Front Panel Programming

You will find these examples on the following pages:

- 1 Setting the output voltage, current, and compensation
- 2 Querying and clearing output protection
- 3 Making front panel measurements
- 4 Programming the digital port
- 5 Setting the HP-IB address or RS-232 parameters
- 6 Saving and recalling operating states

### 1 - Setting the Output Voltage, Current, and Compensation

This example shows you how to set the output voltage and current. It also shows you how to set the compensation circuit for either high or low capacitance cellular phones. Note that no front panel changes affect the output of the unit unless it has been enabled.

#### Set the output voltage

<b>Action</b>	<b>Display</b>
1. To enter an approximate value without using the voltage menu: On the Entry keypad, press <b>←</b> or <b>→</b> to select the 1's digit in the voltage field. Then rotate the front panel RPG knob to obtain 7 V. <i>If the unit is in CC mode, you won't see the output voltage change until the voltage setting is low enough to cause the unit to go into CV mode.</i>	7.003V 0.004A
2. The easiest way to enter an accurate value: On the Function keypad, press <b>Voltage</b> . On the Entry keypad, press <b>Enter Number, 7, Enter</b> .	VOLT 7.000
3. To make minor changes to an existing value: On the Function keypad, press <b>Voltage</b> . On the Entry keypad, press <b>←</b> or <b>→</b> to select the digit in the numeric field that you wish to change. For example, move the flashing digit to the ones column to change a value in this column. Then, press <b>↑</b> to scroll from 7.000 to 8.000. Then press <b>Enter</b> .	VOLT 8.000

#### Set the output current limit

<b>Action</b>	<b>Display</b>
1. To enter an approximate value without using the current menu: On the Entry keypad, press <b>←</b> or <b>→</b> to select the tenths digit in the current field. Rotate the front panel RPG knob to obtain 0.4A. <i>If the unit is in CV mode, you will not see the output current change until the current setting is low enough to cause the unit to go into CC mode.</i>	8.003V 0.400A
2. The easiest way to enter an accurate value: On the Function keypad, press <b>Current</b> . On the Entry keypad, press <b>Enter Number, .4, Enter</b> .	CURR 0.400
3. To make minor changes to an existing value: On the Function keypad, press <b>Current</b> . On the Entry keypad, press <b>←</b> or <b>→</b> to select the digit in the numeric field that you wish to change. For example, move the flashing digit to the tenths column to change a value in this column. Then, press <b>↑</b> to scroll from 0.400 to 0.500. Then press <b>Enter</b> .	CURR 0.500

---

**NOTE:** To output currents pulses greater than 3 A and up to 5 A peak, you must set the output current limit to greater than 3 amperes (3.0712 amperes max).

---

### Set the output compensation

Action	Display
1. On the Function keypad, press <b>Output</b> . Then press ▼ until you obtain the TYPE:CAP command. Use the ↓ key and select either LOW or HIGH. Then press <b>Enter</b> . Use HIGH compensation for phones with input capacitances greater than 5 μF. Use LOW compensation for phones with input capacitances under 5 μF.	TYPE:CAP HIGH

### Enable the output

Action	Display
1. On the Function keypad, press <b>Output On/Off</b> to enable the output. The <b>Dis</b> annunciator will go off, indicating that the voltage is now applied to the output terminals. The A display indicates the actual output current.	8.003V 0.500A

## 2 - Querying and Clearing Output Protection and Errors

If an overvoltage, overcurrent, overtemperature or remote inhibit condition occurs, the **Prot** annunciator on the front panel will be on and the dc source will disable its output. If necessary, you can disable the overcurrent or overvoltage protection circuit if its operation interferes with the proper operation of your phone test. Note that if you disable the overvoltage protection, the equipment under test will not be protected from output voltage overshoot conditions. You can also disable the broken sense lead detect circuit if you have an application where an external voltage applied to the output may interfere with the broken sense lead detect circuitry.

Error messages can occur at any time during the operation of the unit. When the **Err** annunciator on the front panel is on it means that either an error has occurred on the HP-IB bus, or a selftest error has occurred. Appendix C lists error numbers and descriptions.

### Query and clear the dc source overcurrent protection as follows:

Action	Display
1. On the Function keypad, press <b>Protect</b> . In this example, an over current condition has occurred. Refer to Table 4-2 for other protection indicators.	OVERCURRENT
2. On the Function keypad, press <b>Current</b> . This displays the present current limit.	CURR 3.0712
3. To restore normal operation <i>after the cause of the overcurrent condition has been removed</i> , press <b>Shift, Prot Clr</b> . The <b>Prot</b> annunciator then will go off.	
4. To disable overcurrent protection, press <b>Shift, OCP</b> . This key toggles between OCP enabled and disabled. The OCP annunciator is off when OCP is disabled.	

### Disable Overvoltage Protection as follows:

1. On the Function keypad, press <b>Shift, OV</b> . Then press ▼ to obtain the PROT:STAT command. Use the ↓ key and select OFF to disable the overvoltage protection function. Then press <b>Enter</b> . To recall this state when the unit is powered on, save this instrument setup or state in location 0 as explained in example #6.	PROT:STAT OFF
--	---------------

### Query and Clear Errors as follows:

1. On the Function keypad, press <b>Shift, Error</b> . This displays and clears the error in the error queue. Repeatedly press these keys to clear all errors in the queue. If errors persist, your unit may require service.	ERROR 0
---	---------

### 3 – Making Front Panel Measurements

As shipped from the factory, front panel measurements are calculated from a total of 2048 readings taken at a 46.8 microsecond sampling rate. The unit alternates between voltage and current measurements. Therefore, the data acquisition time for a single front panel voltage or current measurement is about 100 milliseconds. This sampling rate and data acquisition time combined with a built-in windowing function, reduces errors due to sampling a non-integral number of cycles of a waveform for frequencies of 25 Hz or greater. Note that the windowing function is less accurate when measuring output waveforms for frequencies less than 25 Hz, causing the front panel meter to jitter.

There are no trigger controls for front panel measurements. However, you can vary both the sampling rate and the number of data points in each front panel measurement using commands in the Input menu. With this flexibility, measurement accuracy can be improved for waveforms with frequencies as low as several Hertz. The sample buffer size may be varied from 1 to 2048 data points in discrete binary values. The sampling rate may be varied from 15.6 microseconds to 1 second. Values are rounded to the nearest 15.6 microsecond interval. Note that the front panel sample interval and buffer size settings are independent of the sample interval and buffer size that you program over the HP-IB. This is because you can qualify measurement triggers over the HP-IB, which makes the HP-IB measurements independent of the front panel measurements. Refer to chapter 8 for more information about HP-IB measurements.

#### HP 66311B Enhanced Measurement Capabilities:

The following figure illustrates the enhanced measurement capabilities of the HP 66311B for measuring output waveforms. These include peak (max), minimum, high level, and low level measurements as illustrated in the following figure. Rms and dc voltages are calculated from the number of points in the measurement window.

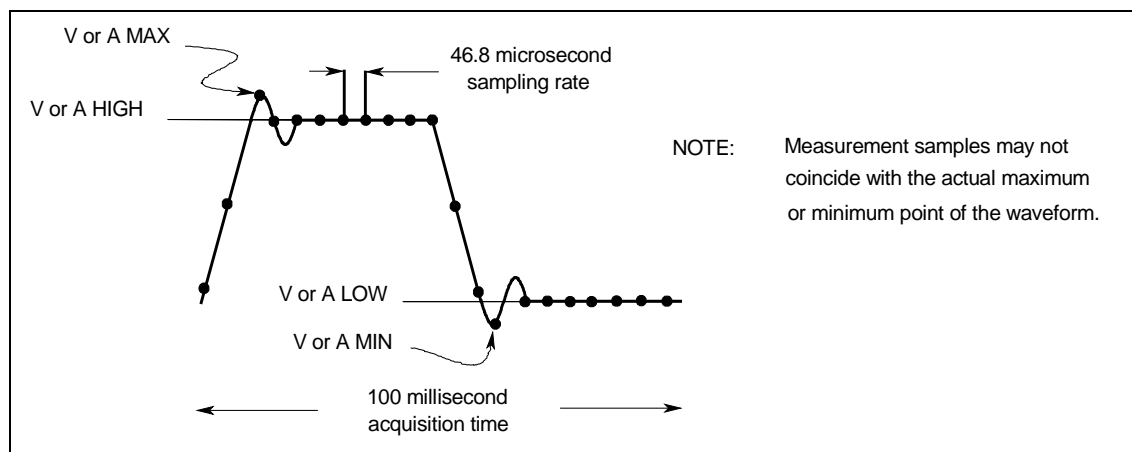

**Figure 5-5. Default Front Panel Measurement Parameters**

The HP 66311B has two current measurement ranges that can be selected in the Input menu. A high current range is available for measuring output currents of up to 7 amperes. A low current range is available for improved resolution when measuring output currents below 20 milliamperes. The low current measurement range is accurate to 0.1% of the reading  $\pm 2.5$  microamperes. When the current Range is set to AUTO, the unit automatically selects the range with the best measurement resolution.

---

**NOTE:** If the front panel display indicates OVLD, the output has exceeded the measurement capability of the instrument. If the front panel display indicates - - - - - , an HP-IB measurement is in progress.

---

**Use the Meter menu for making front panel measurements:**

<b>Action</b>	<b>Display</b>
1. On the Function keypad press <b>Meter</b> and press ▼ repeatedly to access the following measurement parameters: <ul style="list-style-type: none"> <li>◆ dc voltage and current</li> <li>◆ peak voltage<sup>1</sup></li> <li>◆ minimum voltage<sup>1</sup></li> <li>◆ high level of a voltage pulse waveform<sup>1</sup></li> <li>◆ low level of a voltage pulse waveform<sup>1</sup></li> <li>◆ rms voltage<sup>1</sup></li> <li>◆ peak current<sup>1</sup></li> <li>◆ minimum current<sup>1</sup></li> <li>◆ high level of a current pulse waveform<sup>1</sup></li> <li>◆ low level of a current pulse waveform<sup>1</sup></li> <li>◆ rms current<sup>1</sup></li> </ul>	<reading>V <reading>A <reading>V MAX <reading>V MIN <reading>V HIGH <reading>V LOW <reading>V RMS <reading>A MAX <reading>A MIN <reading>A HIGH <reading>A LOW <reading>A RMS
<sup>1</sup> Only available on HP Model 66311B	
2. To change the front panel time interval and buffer size for output waveform measurements, press <b>Shift, Input</b> . Then press ▼ until you obtain the TINT command. Use the Entry keys to enter a value from 15.6 microseconds to 1 second in <i>seconds</i> . Then press <b>Enter</b> .	TINT 0.002
3. Continue by pressing <b>Shift, Input</b> and ▼ until you obtain the POINT command. Press ▼ to select a different buffer size. The choices are: 1, 2, 4, 8, 16, 32, 64, 128, 256, 512, 1024, and 2048. Then press <b>Enter</b> .	POINT 1024

One reason to change the front panel time interval and data points is if the waveform being measured has a period shorter than 3 times the present front panel acquisition time.

**HP 66311B Enhanced Measurement Capabilities:**

4. For current measurements, press <b>Shift, Input</b> . Then press ▼ until you obtain the CURR:RANG AUTO command. Press <b>Enter</b> to activate autoranging. Two other selections are also available. Select the HIGH range when measuring currents above 20 mA. Select the LOW range for improved resolution when measuring currents below 20 mA. Note that the LOW range is only appropriate for making dc measurements.	CURR:RANG AUTO
5. For output waveform measurements, press <b>Shift, Input</b> . Then press ▼ until you obtain the CURR:DET command. Check to make sure that the ACDC current detector is selected. This provides the best accuracy for waveform measurements. Only select the DC current detector if you are making dc current measurements and you require a dc measurement offset better than 2mA on the High current measurement range. Press <b>Enter</b> to activate any changes.	CURR:DET ACDC <sup>1</sup>

---

**NOTE:** In the LOW current measurement range, the current detector is fixed at DC. With the current detector in dc, accurate current measurements cannot be made on waveforms with frequency contents over 1 kilohertz.

---

## 5 – Front Panel Operation

### 4 - Programming External Protection and the Digital Port Functions

Your dc source is shipped with the output port function set to RIDFI mode. In this mode the port functions as a remote inhibit input with a discrete fault indicator output signal. You can also configure the port to act as a Digital Input/Output device.

**To configure the RIDFI mode of the port, proceed as follows:**

Action	Display
1. On the Function keypad, press <b>Output</b> .	*RST
2. Scroll through the Output menu by pressing ▼. The PORT command lets you select either the RIDFI or the DIGIO function. Press <b>Enter</b> when done.	PORT RIDFI
3. Scroll to the RI command to configure the Remote INHibit indicator. Use the ↑ and ↓ keys to select either LIVE or LATCHING, either of which enable the RI indicator. Then press <b>Enter</b> . With RI enabled, a low-true on the INH input will disable the output of the unit. LIVE causes the output of the unit to track the state of the INH input. LATCHING latches the output of the unit off in response to the inhibit signal.	RI LIVE RI LATCHING
4. Access the Output menu again and scroll through the menu. The DFI command lets you enable the Discrete Fault Indicator. Use the ↓ key and select ON to enable the FLT output. Then press <b>Enter</b> . With the FLT output enabled, the open-collector logic signal can be used to signal external devices when a fault condition is detected.	DFI ON
5. Scroll to the DFI:SOUR command to select the internal source that drives this signal. Use the ↓ key to select from the RQS or ESB bits, or the Operation or Questionable status registers. Then press <b>Enter</b> . Status summary bits are explained in chapter 7.	DFI:SOUR RQS DFI:SOUR ESB DFI:SOUR OPER DFI:SOUR QUES

**To configure the DIGIO mode of the port, proceed as follows:**

Action	Display
1. On the Function keypad, press <b>Output</b> .	*RST
2. Scroll through the Output menu by pressing ▼. The PORT command lets you select either the RIDFI or the DIGIO function. Press <b>Enter</b> when done.	PORT DIGIO
3. Scroll to the DIGIO command to set and read the Digital Input/Output Port. Press <b>Enter Number</b> and enter a number from 0 to 7 to program the three bits (0 programs all bits low; 7 programs all bits high). Press <b>Enter</b> when done.	DIGIO 5

### 5 - Setting the HP-IB Address and RS-232 Parameters

Your dc source is shipped with the HP-IB address set to 5. This address can only be changed from the front panel using the Address menu located under the **Address** key. This menu is also used to select the RS-232 interface and specify RS-232 parameters such baud rate and parity.

**Set the HP-IB address as follows:**

Action	Display
1. On the System keypad, press <b>Address</b> .	ADDRESS 5
2. Enter the new address. For example, Press <b>Enter Number, 7, Enter</b> .	ADDRESS 7

**Configure the RS-232 interface as follows:**

<b>Action</b>	<b>Display</b>
1. On the System keypad, press <b>Address</b> .	ADDRESS 5
2. Scroll through the Address menu by pressing ▼. The interface command lets you select the RS-232 interface. The baudrate command lets you select the baudrate. The parity command lets you select the parity. The flow command selects the flow control options.	INTF RS232 BAUDRATE 9600 PARITY EVEN FLOW XON-XOFF
3. The ↑ and ↓ keys let you select the command parameters. Press <b>Enter</b> when done.	

## 6 - Saving and Recalling Operating States

You can save up to 4 states (from location 0 to location 3) in non-volatile memory and recall them from the front panel. All programmable settings are saved. This capability is only available when the unit is set to the SCPI programming language.

---

**NOTE:** You can program the unit to automatically power-on according to the operating state that is saved in location 0 as shown in the third example on this page.

---

### Save an operating state in location 0 as follows:

<b>Action</b>	<b>Display</b>
1. Set the instrument to the operating state that you want to save.	
2. Save this state to location 0. Press <b>Save, Enter Number, 0, Enter</b> .	*SAV 0

### Recall a saved state as follows:

<b>Action</b>	<b>Display</b>
1. Recall the state saved in location 0 by pressing <b>Recall, Enter Number, 0, Enter</b>	*RCL 0

### Select the power-on state of the dc source as follows:

<b>Action</b>	<b>Display</b>
1. On the Function keypad, press <b>Output</b> , and scroll through the Output menu until you get to the PON state command.	PON:STATE RST
2. Use the ↑ and ↓ keys to select either RST or RCL0. RST sets the power-on state of the unit as defined by the *RST command. RCL0 sets the power-on state of the unit to the state saved in *RCL location 0. Press <b>Enter</b> when done.	

### Clear the non-volatile memory of the dc source as follows:

<b>Action</b>	<b>Display</b>
1. On the Function keypad, press <b>Output, Enter</b> . This returns the unit to the factory-default settings.	*RST
2. Save these settings to location 0. Press <b>Save, Enter Number, 0, Enter</b> .	*SAV 0
3. Repeat step #2 for memory locations 1 through 3.	*SAV 1 *SAV 2 *SAV 3





## Introduction to Programming

---

### HP-IB Capabilities of the DC Source

All dc source functions except for setting the HP-IB address are programmable over the HP-IB. The IEEE 488.2 capabilities of the dc source are listed in the Specifications Table in Appendix A.

#### HP-IB Address

The dc source operates from an HP-IB address that is set from the front panel. To set the HP-IB address, press the **Address** key on the front panel and enter the address using the Entry keys. The address can be set from 0 to 30. The HP-IB address is stored in non-volatile memory.

ADDRESS <value>                      Enter a value to set the HP-IB Address

---

### RS-232 Capabilities of the DC Source

The dc source provides an RS-232 programming interface, which is activated by commands located under the front panel **Address** key. All SCPI and COMPatibility commands are available through RS-232 programming. When the RS-232 interface is selected, both the HP-IB interface and the optional HP 14575A Remote Front Panel interface is disabled.

The EIA RS-232 Standard defines the interconnections between Data Terminal Equipment (DTE) and Data Communications Equipment (DCE). The dc source is designed to be a DTE. It can be connected to another DTE such as a PC COM port through a null modem cable.

---

**NOTE:**                      The RS-232 settings in your program must match the settings specified in the front panel Address menu. Press the front panel **Address** key if you need to change the settings.

---

#### RS-232 Data Format

The RS-232 data is a 10-bit word with one start bit and one stop bit. The number of start and stop bits is not programmable. The following parity options are selectable using the front panel Address key:

EVEN	Seven data bits with even parity
ODD	Seven data bits with odd parity
MARK	Seven data bits with mark parity (parity is always true)
SPACE	Seven data bits with space parity (parity is always false)
NONE	Eight data bits without parity

Parity options are stored in non-volatile memory.

#### Baud Rate

The front panel Address key lets you select one of the following baud rates, which is stored in non-volatile memory:    300        600        1200        2400        4800        9600

## 6 - Introduction to Programming

### RS-232 Flow Control

The RS-232 interface supports several flow control options that are selected using the front panel Address key. For each case, the dc source will send a maximum of five characters after holdoff is asserted by the controller. The dc source is capable of receiving as many as fifteen additional characters after it asserts holdoff.

XON-XOFF	A software handshake that uses the ASCII control code DC3 (decimal code 19) to assert hold-off, and control code DC1 (decimal code 17) to release hold-off.
RTS-CTS	The dc source asserts its Request to Send (RTS) line to signal hold-off when its input buffer is almost full, and it interprets its Clear to Send (CTS) line as a hold-off signal from the controller.
DTR-DSR	The dc source asserts its Data Terminal Ready (DTR) line to signal hold-off when its input buffer is almost full, and it interprets its Data Set Ready (DSR) line as a hold-off signal from the controller.
NONE	There is no flow control.

Flow control options are stored in non-volatile memory.

---

## Introduction to SCPI

SCPI (Standard Commands for Programmable Instruments) is a programming language for controlling instrument functions over the HP-IB. SCPI is layered on top of the hardware-portion of IEEE 488.2. The same SCPI commands and parameters control the same functions in different classes of instruments. For example, you would use the same DISPlay command to control the dc source display and the display of a SCPI-compatible multimeter.

### SCPI References

The following documents will assist you with programming in SCPI:

- ◆ *Standard Commands for Programmable Instruments Volume 1, Syntax and Style*
- ◆ *Standard Commands for Programmable Instruments Volume 2, Command References*
- ◆ *Standard Commands for Programmable Instruments Volume 3, Data Interchange Format*
- ◆ *Standard Commands for Programmable Instruments Volume 4, Instrument Classes*

To obtain a copy of the above documents, contact: Fred Bode, Executive Director, SCPI Consortium, 8380 Hercules Drive, Suite P3, Ls Mesa, CA 91942, USA

### HP-IB References

The most important HP-IB documents are your controller programming manuals - HP BASIC, HP-IB Command Library for MS DOS, etc. Refer to these for all non-SCPI commands (for example: Local Lockout).

The following are two formal documents concerning the HP-IB interface:

- ◆ *ANSI/IEEE Std. 488.1-1987 IEEE Standard Digital Interface for Programmable Instrumentation.*  
Defines the technical details of the HP-IB interface. While much of the information is beyond the need of most programmers, it can serve to clarify terms used in this guide and in related documents.
- ◆ *ANSI/IEEE Std. 488.2-1987 IEEE Standard Codes, Formats, Protocols, and Common Commands.*  
Recommended as a reference only if you intend to do fairly sophisticated programming. Helpful for finding precise definitions of certain types of SCPI message formats, data types, or common commands.

The above two documents are available from the IEEE (Institute of Electrical and Electronics Engineers), 345 East 47th Street, New York, NY 10017, USA. The WEB address is [www.ieee.org](http://www.ieee.org).

## Conventions Used in This Guide

Angle brackets	< >	Items within angle brackets are parameter abbreviations. For example, <NR1> indicates a specific form of numerical data.
Vertical bar		Vertical bars separate alternative parameters. For example, NORM   TEXT indicates that either "TEXT" or "NORM" can be used as a parameter.
Square Brackets	[ ]	Items within square brackets are optional. The representation [SOURce:]. VOLTage means that SOURce: may be omitted.
Braces	{ }	Braces indicate parameters that may be repeated zero or more times. It is used especially for showing arrays. The notation <A>{<,B>} shows that parameter "A" must be entered, while parameter "B" may be omitted or may be entered one or more times.
<b>Boldface</b> font		Boldface font is used to emphasize syntax in command definitions. <b>TRIGger:COUNT:CURRENT &lt;NRf&gt;</b> shows command definition.
Computer font		Computer font is used to show program lines in text. <code>TRIGger:COUNT:CURRENT 10</code> shows a program line.

---

## Types of SCPI Commands

SCPI has two types of commands, common and subsystem.

- ◆ Common commands generally are not related to specific operation but to controlling overall dc source functions, such as reset, status, and synchronization. All common commands consist of a three-letter mnemonic preceded by an asterisk: \*RST \*IDN? \*SRE 8
- ◆ Subsystem commands perform specific dc source functions. They are organized into an inverted tree structure with the "root" at the top. The following figure shows a portion of a subsystem command tree, from which you access the commands located along the various paths. You can see the complete tree in Table 8-1.

## 6 - Introduction to Programming

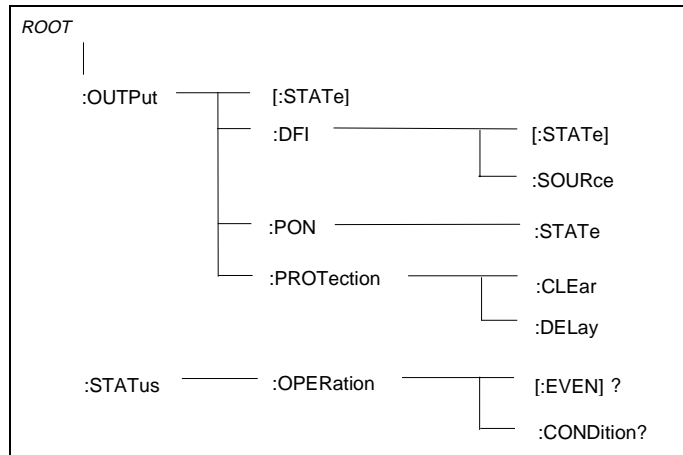

Figure 6-1. Partial Command Tree

### Multiple Commands in a Message

Multiple SCPI commands can be combined and sent as a single message with one message terminator. There are two important considerations when sending several commands within a single message:

- ◆ Use a semicolon to separate commands within a message.
- ◆ There is an implied header path that affects how commands are interpreted by the dc source.

The header path can be thought of as a string that gets inserted **before** each command within a message. For the first command in a message, the header path is a null string. For each subsequent command the header path is defined as the characters that make up the headers of the previous command in the message up to and including the last colon separator. An example of a message with two commands is:

```
OUTP:STAT ON;PROT:DEL 2
```

which shows the use of the semicolon separating the two commands, and also illustrates the header path concept. Note that with the second command, the leading header "OUTP" was omitted because after the "OUTP:STAT ON" command, the header path was became defined as "OUTP" and thus the instrument interpreted the second command as:

```
OUTP:PROT:DEL 2
```

In fact, it would have been syntactically incorrect to include the "OUTP" explicitly in the second command, since the result after combining it with the header path would be:

```
OUTP:OUTP:PROT:DEL 2
```

which is incorrect.

### Moving Among Subsystems

In order to combine commands from different subsystems, you need to be able to reset the header path to a null string within a message. You do this by beginning the command with a colon (:), which discards any previous header path. For example, you could clear the output protection and check the status of the Operation Condition register in one message by using a root specifier as follows:

```
OUTPut:PROTection:CLEAr;:STATus:OPERation:CONDition?
```

The following message shows how to combine commands from different subsystems as well as within the same subsystem:

```
VOLTage:LEVEl 20;PROTection 28;;CURREnt:LEVEl 3;PROTection:STATe ON
```

Note the use of the optional header `LEVEL` to maintain the correct path within the voltage and current subsystems, and the use of the root specifier to move between subsystems.

## Including Common Commands

You can combine common commands with system commands in the same message. Treat the common command as a message unit by separating it with a semicolon (the message unit separator). Common commands *do not affect the header path*; you may insert them anywhere in the message.

```
VOLTage:TRIGgered 17.5;;INITialize;*TRG
OUTPut OFF;*RCL 2;OUTPut ON
```

## Using Queries

Observe the following precautions with queries:

- ◆ Set up the proper number of variables for the returned data.
- ◆ Read back all the results of a query before sending another command to the dc source. Otherwise a *Query Interrupted* error will occur and the unreturned data will be lost.

---

## Types of SCPI Messages

There are two types of SCPI messages, program and response.

- ◆ A *program message* consists of one or more properly formatted SCPI commands sent from the controller to the dc source. The message, which may be sent at any time, requests the dc source to perform some action.
- ◆ A *response message* consists of data in a specific SCPI format sent from the dc source to the controller. The dc source sends the message only when commanded by a program message "query."

The following figure illustrates SCPI message structure:

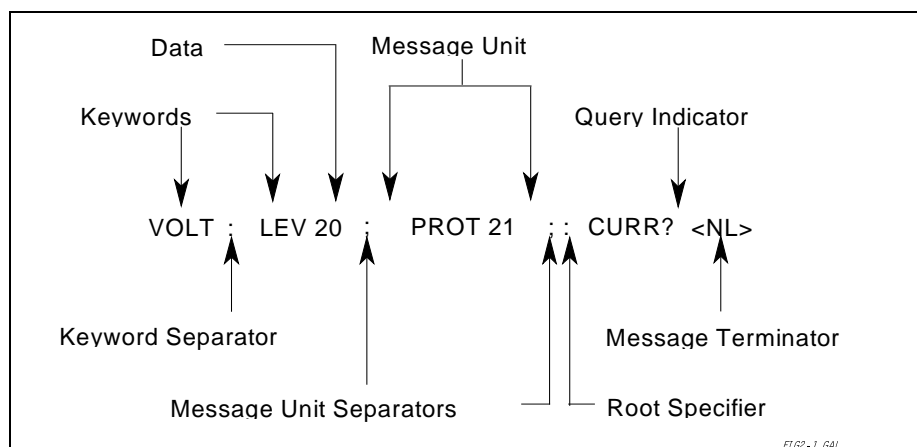

**Figure 6-2. Command Message Structure**

## 6 - Introduction to Programming

### The Message Unit

The simplest SCPI command is a single message unit consisting of a command header (or keyword) followed by a message terminator. The message unit may include a parameter after the header. The parameter can be numeric or a string.

```
ABORt<NL>
VOLTage 20<NL>
```

### Headers

Headers, also referred to as keywords, are instructions recognized by the dc source. Headers may be either in the long form or the short form. In the long form, the header is completely spelled out, such as VOLTAGE, STATUS, and DELAY. In the short form, the header has only the first three or four letters, such as VOLT, STAT, and DEL.

### Query Indicator

Following a header with a question mark turns it into a query (VOLTage?, VOLTage:PROTection?). If a query contains a parameter, place the query indicator at the end of the last header.

```
VOLTage:PROTection? MAX
```

### Message Unit Separator

When two or more message units are combined into a compound message, separate the units with a semicolon.

```
STATus:OPERation?;QUESTionable?
```

### Root Specifier

When it precedes the first header of a message unit, the colon becomes the root specifier. It tells the command parser that this is the root or the top node of the command tree.

### Message Terminator

A terminator informs SCPI that it has reached the end of a message. Three permitted message terminators are:

- ◆ newline (<NL>), which is ASCII decimal 10 or hex 0A.
- ◆ end or identify (<END>)
- ◆ both of the above (<NL><END>).

In the examples of this guide, there is an assumed message terminator at the end of each message.

---

**NOTE:** All RS-232 response data sent by the dc source is terminated by the ASCII character pair <carriage return><newline>. This differs from HP-IB response data, which is terminated by the single character <newline> with EOI asserted.

---

## SCPI Data Formats

All data programmed to or returned from the dc source is ASCII. The data may be numerical or character string.

### Numerical Data Formats

Symbol	Data Form
	<u>Talking Formats</u>
<NR1>	Digits with an implied decimal point assumed at the right of the least-significant digit. Examples: <b>273</b>
<NR2>	Digits with an explicit decimal point. Example: <b>.0273</b>
<NR3>	Digits with an explicit decimal point and an exponent. Example: <b>2.73E+2</b>
	<u>Listening Formats</u>
<Nrf>	Extended format that includes <NR1>, <NR2> and <NR3>. Examples: <b>273 273. 2.73E2</b>
<Nrf+>	Expanded decimal format that includes <Nrf> and <b>MIN MAX</b> . Examples: <b>273 273. 2.73E2 MAX. MIN</b> and <b>MAX</b> are the minimum and maximum limit values that are implicit in the range specification for the parameter.
<Bool>	Boolean Data. Example: <b>0   1</b> or <b>ON   OFF</b>

### Suffixes and Multipliers

Class	Suffix	Unit	Unit with Multiplier
Current	A	ampere	MA (milliampere)
Amplitude	V	volt	MV (millivolt)
Time	S	second	MS (millisecond)
<b>Common Multipliers</b>			
	1E3	K	kilo
	1E-3	M	milli
	1E-6	U	micro

### Response Data Types

Character strings returned by query statements may take either of the following forms, depending on the length of the returned string:

- <CRD> Character Response Data. Permits the return of character strings.
- <AARD> Arbitrary ASCII Response Data. Permits the return of undelimited 7-bit ASCII. This data type has an implied message terminator.
- <SRD> String Response Data. Returns string parameters enclosed in double quotes.

## SCPI Command Completion

SCPI commands sent to the dc source are processed either sequentially or in parallel. Sequential commands finish execution before a subsequent command begins. Parallel commands allow other commands to begin executing while the parallel command is still executing. Commands that affect trigger actions are among the parallel commands.

The `*WAI`, `*OPC`, and `*OPC?` common commands provide different ways of indicating when all transmitted commands, including any parallel ones, have completed their operations. The syntax and parameters for these commands are described in chapter 8. Some practical considerations for using these commands are as follows:

<code>*WAI</code>	This prevents the dc source from processing subsequent commands until all pending operations are completed.
<code>*OPC?</code>	This places a 1 in the Output Queue when all pending operations have completed. Because it requires your program to read the returned value before executing the next program statement, <code>*OPC?</code> can be used to cause the controller to wait for commands to complete before proceeding with its program.
<code>*OPC</code>	This sets the OPC status bit when all pending operations have completed. Since your program can read this status bit on an interrupt basis, <code>*OPC</code> allows subsequent commands to be executed.

---

**NOTE:** The trigger subsystem must be in the Idle state in order for the status OPC bit to be true. Therefore, as far as triggers are concerned, OPC is false whenever the trigger subsystem is in the Initiated state.

---

---

## Using Device Clear

You can send a device clear at any time abort a SCPI command that may be hanging up the HP-IB interface. The status registers, the error queue, and all configuration states are left unchanged when a device clear message is received. Device clear performs the following actions:

- ◆ The input and output buffers of the dc source are cleared.
- ◆ The dc source is prepared to accept a new command string.

The following statement shows how to send a device clear over the HP-IB interface using *HP BASIC*:

```
CLEAR 705      IEEE-488 Device Clear
```

The following statement shows how to send a device clear over the HP-IB interface using the HP-IB command library for *C* or *QuickBASIC*:

```
IOCLEAR (705)
```

---

**NOTE:** For RS-232 operation, sending a Break will perform the same operation as the IEEE-488 device clear message.

---



## RS-232 Troubleshooting

If you are having trouble communicating over the RS-232 interface, check the following:

- ◆ The computer and the dc source must be configured for the same baud rate, parity, number of data bits, and flow control options. Note that the dc source is configured for 1 start bit and 1 stop bit (these values are fixed).
- ◆ The correct interface cables or adapters must be used, as described under RS-232 Connector. Note that even if the cable has the proper connectors for your system, the internal wiring may be incorrect.
- ◆ The interface cable must be connected to the correct serial port on your computer (COM1, COM2, etc.).

## SCPI Conformance Information

The HP 66111A and 66311B conform to SCPI Version 1995.0.

### SCPI Conformed Commands

ABOR	OUTP:PROT:DEL	STAT:QUES:ENAB
CAL:DATA	OUT:PROT:STAT	STAT:QUES:NTR
CAL:STAT	[SOUR]:CURR[:LEV][:IMM][:AMPL]	STAT:QUES:PTR
DISP[:WIND][:STAT]	[SOUR]:CURR[:LEV]:TRIG[:AMPL]	SYST:ERR?
DISP[:WIND]:TEXT[:DATA]	[SOUR]:CURR:PROT:STAT	SYST:LANG
INIT[:IMM]:SEQ   NAME	[SOUR]:VOLT[:LEV][:IMM][:AMPL]	SYST:VERS?
INIT:CONT:SEQ	[SOUR]:VOLT[:LEV]:TRIG[:AMPL]	TRIG[:SEQ1   :TRAN][:IMM]
MEAS   FETC:ARR:CURR[:DC]?	[SOUR]:VOLT:PROT	TRIG[:SEQ1   :TRAN]:SOUR
MEAS   FETC:ARR:VOLT[:DC]?	SENS:CURR[:DC]:RANG[:UPP]	TRIG:SEQ2   ACQ[:IMM]
MEAS   FETC[:SCAL]:CURR[:DC]?	SENS:FUNC	TRIG:SEQ2   ACQ:SOUR
MEAS   FETC[:SCAL]:CURR:HIGH?	SENS:SWE:OFFS:POIN	TRIG:SEQ:DEF
MEAS   FETC[:SCAL]:CURR:LOW?	SENS:SWE:POIN	*CLS
MEAS   FETC[:SCAL]:CURR:MAX?	SENS:SWE:TINT	*ESE*ESE?*ESR?
MEAS   FETC[:SCAL]:CURR:MIN?	STAT:OPER[:EVEN]?	*IDN?
MEAS   FETC[:SCAL]:VOLT[:DC]?	STAT:OPER:COND?	*OPC*OPC?*OPT?
MEAS   FETC[:SCAL]:VOLT:HIGH?	STAT:OPER:ENAB	*PSC*PSC?
MEAS   FETC[:SCAL]:VOLT:LOW?	STAT:OPER:NTR	*RCL*RST
MEAS   FETC[:SCAL]:VOLT:MAX?	STAT:OPER:PTR	*SAV*SRE*STB?
MEAS   FETC[:SCAL]:VOLT:MIN?	STAT:PRES	*TRG*TST?
OUTP[:STAT]	STAT:QUES[:EVEN]?	*WAI
OUTP:PROT:CLE	STAT:QUES:COND?	

### Non-SCPI Commands

CAL:CURR[:SOUR][:DC][:POS]	OUTP:DFI[:STAT]
CAL:CURR[:SOUR][:DC]:NEG	OUTP:DFI:SOUR
CAL:MEAS[:DC]:LOWR	OUTP:PON:STAT
CAL:MEAS:AC	OUTP:RI:MODE
CAL:LEV	OUTP:TYPE
CAL:PASS	SENS:CURR:DET
CAL:SAVE	[SOUR]:DIG:DATA[:VAL]
CAL:VOLT[:DC]	[SOUR]:DIG:FUNC
CAL:VOLT:PROT	TRIG:SEQ2   ACQ:COUN:CURR   :VOLT
DISP[:WIND]:MODE	TRIG:SEQ2   ACQ:HYST:CURR   :VOLT
MEAS   FETC[:SCAL]:CURR:ACDC?	TRIG:SEQ2   ACQ:LEV:CURR   :VOLT
MEAS   FETC[:SCAL]:VOLT:ACDC?	TRIG:SEQ2   ACQ:SLOP:CURR   :VOLT



# Programming the DC Source

---

## Introduction

This chapter contains examples on how to program your dc source. Simple examples show you how to program:

- ◆ output functions such as voltage and current
- ◆ internal and external triggers
- ◆ measurement functions
- ◆ the status and protection functions

---

**NOTE:** These examples in this chapter show which commands are used to perform a particular function, but do not show the commands being used in any particular programming environment. Refer to Appendix D for some examples of SCPI commands in a specific programming environment.

---

---

## Programming the Output

### Power-on Initialization

When the dc source is first turned on, it wakes up with the output state set OFF. In this state the output voltage is set to 0. The following commands are given implicitly at power-on:

```
*RST
*CLS
STATus:PRESet
*SRE 0
*ESE 0
```

\*RST is a convenient way to program all parameters to a known state. Refer to the \*RST command in chapter 8 to see how each programmable parameter is set by \*RST. Refer to the \*PSC command in chapter 8 for more information on the power-on initialization of the \*ESE and the \*SRE registers.

### Enabling the Output

To enable the output, use the command:

```
OUTPut ON
```

## 7 - Programming the DC Source

### Output Voltage

The output voltage is controlled with the VOLTage command. For example, to set the output voltage to 15 volts, use:

```
VOLTage 15
```

### Maximum Voltage

The maximum rms output voltage that can be programmed can be queried with:

```
VOLTage? MAX
```

### Overvoltage Protection

The dc source can be programmed to turn off its output if the output voltage exceeds a preset peak voltage limit. As explained in chapter 8, this protection feature is implemented with the following command:

```
VOLTage:PROTection <n>
```

where <n> is the voltage protection level.

---

**NOTE:** Use the VOLT:PROT:STAT 0 command to disable the overvoltage protection circuit if its operation interferes with the proper operation of your phone test.

---

### Output Current

All models have a programmable current function. The command to program the current is:

```
CURRent <n>
```

where <n> is the current limit in amperes.

If the load attempts to draw more current than the programmed limit, the output voltage is reduced to keep the current within the limit.

### Maximum Current

The maximum output current that can be programmed can be queried with:

```
CURRent? MAX
```

### Overcurrent Protection

The dc source can also be programmed to turn off its output if the current limit is reached. As explained in chapter 8, this protection feature is implemented the following command:

```
CURRent:PROTection:STATe ON | OFF
```

---

**NOTE:** Use the OUTP:PROT:DEL command to prevent momentary current limit conditions caused by programmed output changes from tripping the overcurrent protection.

---

## Triggering Output Changes

The dc source has two independent trigger systems. One is used for generating output changes, and the other is used for triggering measurements. This section describes the output trigger system. The measurement trigger system is described under "Triggering Measurements".

### SCPI Triggering Nomenclature

In SCPI terms, trigger systems are called sequences. When more than one trigger system exists, they are differentiated by naming them SEQUENCE1 and SEQUENCE2. SEQUENCE1 is the transient trigger system and SEQUENCE2 is the measurement trigger system. The dc source uses aliases with more descriptive names for these sequences. These aliases can be used instead of the sequence forms.

Sequence Form	Alias
SEQUENCE1	TRANSient
SEQUENCE2	ACQUIRE

### Output Trigger System Model

Figure 7-1 is a model of the output trigger system. The rectangular boxes represent states. The arrows show the transitions between states. These are labeled with the input or event that causes the transition to occur.

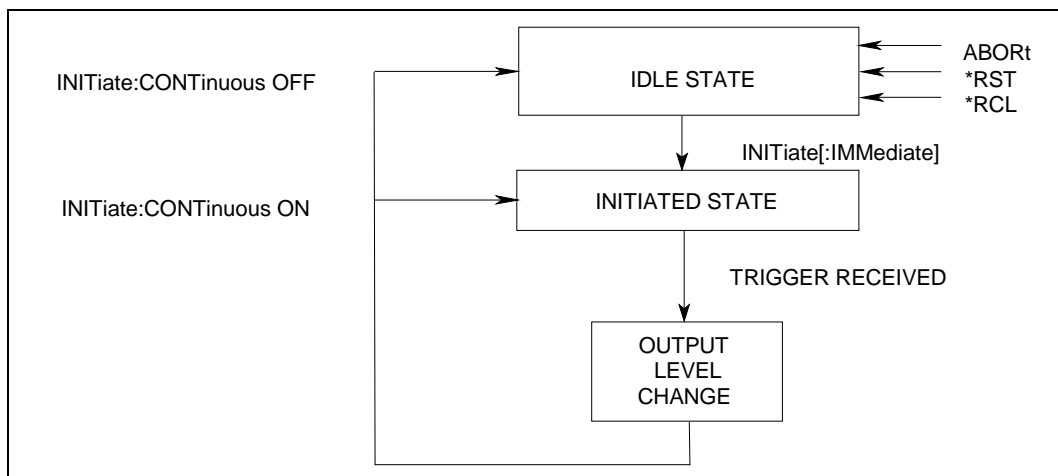

Figure 7-1. Model of Output Triggers

### Setting the Voltage or Current Trigger Levels

To program output trigger levels, you must first specify a voltage or current trigger level that the output will go to once a trigger signal is received. Use the following commands to set the output trigger level:

```
VOLTage:TRIGgered <n>    or
CURRent:TRIGgered <n>
```

**NOTE:** Until they are programmed, trigger levels will be the same as the corresponding voltage or current levels. For example, if a dc source is powered up and the voltage is programmed to 6, then the trigger level is also set to 6. Once you program a trigger level, it will stay at that value regardless of how you subsequently reprogram the voltage.

## 7 - Programming the DC Source

### Initiating the Output Trigger System

When the dc source is turned on, the trigger subsystem is in the idle state. In this state, the trigger subsystem ignores all triggers. Sending the following commands at any time returns the trigger system to the idle state:

```
ABORt
*RST
*RCL
```

The INITiate commands move the trigger system from the idle state to the initiated state. This enables the dc source to receive triggers. To initiate for a single triggered action, use:

```
INITiate:SEQuence1 or
INITiate:NAME TRANSient
```

After a trigger is received and the action completes, the trigger system will return to the idle state. Thus it will be necessary to initiate the system each time a triggered action is desired.

To keep the transient trigger system initiated for multiple actions without having to send an initiate command for each trigger, use:

```
INITiate:CONTinuous:SEQuence1 ON or
INITiate:CONTinuous:NAME TRANSient, ON
```

### Generating Triggers

You can only program output triggers over the HP-IB bus. Since BUS is the only trigger source for output triggers, the following command is provided for completeness only:

```
TRIGger:SOURce BUS
```

### Single Triggers

After you have specified the appropriate trigger source, you can generate triggers by sending one of the following commands over the HP-IB:

```
TRIGger:IMMediate
*TRG
a group execute trigger
```

When the trigger system enters the Output Change state upon receipt of a trigger (see figure 7-1), the triggered functions are set to their programmed trigger levels. When the triggered actions are completed, the trigger system returns to the idle state.

### Multiple Triggers

When you have programmed INITiate:CONTinuous:SEQuence1 ON as previously discussed, the trigger system does not need to be initiated for each trigger; it responds to the next trigger as soon as it is received. When each triggered action completes, the trigger system returns to the initiated state to wait for the next trigger.

## Making Measurements

The HP 66111A and the HP 66311B both have excellent output voltage and current measurement capability. The HP 66311B Mobile Communications Dc Source also has the ability to make several types of voltage or current measurements. These expanded measurement capabilities are particularly useful for loads that draw current in pulses.

---

**NOTE:** Because there is only one measurement buffer, you cannot measure output voltage and current simultaneously.

---

All measurements are performed by digitizing the instantaneous output voltage or current for a defined number of samples and sample interval, storing the results in a buffer, and then calculating the measured result. Many parameters of the measurement are programmable. These include the number of samples, the time interval between samples, and the method of triggering. Note that there is a tradeoff between these parameters and the speed, accuracy, and stability of the measurement in the presence of noise.

There are two ways to make measurements:

- ◆ Use the MEASure commands to immediately start acquiring new voltage or current data, and return measurement calculations from this data as soon as the buffer is full. This is the easiest way to make measurements, since it requires no explicit trigger programming.
- ◆ Use an acquisition trigger to acquire the data as discussed under “Triggering Measurements”. Then use the FETCh commands to return calculations from the data that was retrieved by the acquisition trigger. This method gives you the flexibility to synchronize the data acquisition with a transition in the output voltage or current. FETCh commands do not trigger the acquisition of new measurement data, but they can be used to return many different calculations from the data that was retrieved by the acquisition trigger. Note that if you take a voltage measurement, you can fetch only voltage data.

---

**NOTE:** For each MEASure query, there exists a corresponding FETCh query. FETCh queries perform the same calculation as MEASure queries, but do **not** acquire new data.

---

## Controlling Measurement Samples

You can vary both the number of data points in a measurement sample, as well as the time between samples. This is illustrated in Figure 7-2.

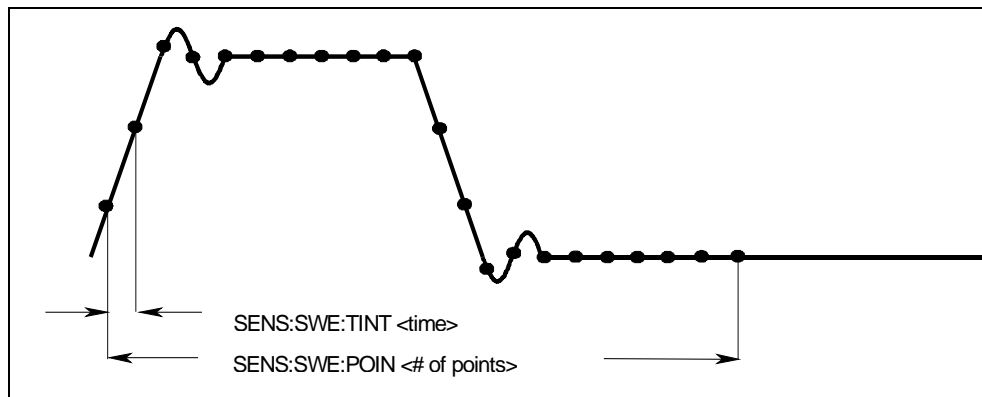

Figure 7-2. Commands that Control Measurement Time

## 7 - Programming the DC Source

When the instrument is turned on and at \*RST, the output voltage or current sampling rate is 15.6 microseconds, and the sweep size is set to 2048 data points. This means that it takes about 32 milliseconds to fill up 2048 data points in the data buffer. Adding a command processing overhead of about 20 milliseconds results in a total measurement time of about 50 milliseconds per measurement. You can vary this data sampling rate with:

```
SENSE:SWEEP:TINTERVAL <sample_period>  
SENSE:SWEEP:POINTS <points>
```

For example, to set the time interval to 46.8 microseconds per measurement with 1500 samples, use

```
SENSE:SWEEP:TINTERVAL 46.8E-6;POINTS 1500.
```

Note that reducing the number of sample points increases the speed of the measurement; however, the tradeoff is greater measurement uncertainty in the presence of noise..

### Current Ranges and Measurement Detector (HP Model 66311B Only)

The dc source has two current measurement ranges. The command that controls the ranges is:

```
SENSE:CURRENT:RANGE MIN | MAX
```

When the range is set to MIN, the maximum current that can be measured is 20 milliamperes. The crossover value of the high and low ranges is 20 milliamperes.

The dc source also has two measurement detectors. Check that the current detector is set to ACDC when measuring current pulses or other waveforms with a frequency content greater than a few kilohertz.

```
SENSE:CURRENT:DETECT ACDC
```

Select DC as the measurement detector if you are making only DC current measurements and you require a measurement offset better than 2mA on the High current measurement range. Note that this selection gives inaccurate results on current waveforms that have ac content.

```
SENSE:CURRENT:DETECT DC
```

### Window Functions

The dc source lets you select from two measurement window functions: Hanning and Rectangular. To select a window function, use:

```
SENSE:WINDOW: HANN | RECT
```

As shipped from the factory, the dc source measurement functions use a Hanning window. The Hanning window applies a  $\cos^4$  weighting function to the data in the measurement buffer when computing measurements such as average and rms. This returns accurate data even if an integral number of waveform cycles are not captured, provided that at least three or more waveform cycles are in the measurement buffer. If there are only one or two waveform cycles, the Hanning window will not give accurate results.

With a Rectangular window, no weighting function is applied to the data in the measurement buffer. However, to use the Rectangular window function to return accurate data for one or more waveform cycles, an integral number of waveform cycles must be captured in the measurement buffer. This means that you must accurately know the waveform period beforehand. In this way you can chose the sample



interval and the number of data points so that an integral number of waveform cycles will end up in the measurement buffer.

## Voltage and Current Measurements

The HP 66311B has a number of waveform measurement capabilities. The SCPI language MEASure and FETCh queries are used to return the various measurement parameters of voltage and current waveforms.

### Average Measurements

To measure the average output voltage or current, use:

```
MEASure:VOLTage? or
MEASure:CURRent?
```

Average voltage and current is measured by acquiring a number of readings at the selected time interval, applying the Hanning window function to the readings, and *averaging* the readings. Windowing is a signal conditioning process that reduces the error in average measurements made in the presence of periodic signals such as pulse current waveforms, which are generated when TDMA cellular phones are transmitting. The power-on and \*RST sample interval and sweep size settings yield a data acquisition time of 32 milliseconds per measurement.

Ripple rejection is a function of the number of cycles of the ripple frequency contained in the acquisition window. More cycles in the acquisition window results in better ripple rejection. If you increase the data acquisition time for each measurement to 45 microseconds for example, this results in 5.53 cycles in the acquisition window at 60 Hz, for a ripple rejection of about 70 dB.

### RMS Measurements (HP Model 66311B Only)

To read the rms content of a voltage or current waveform, use:

```
MEASure:VOLTage:ACDC? or
MEASure:CURRent:ACDC?
```

This returns the total rms measurement.

Making rms or average measurements on ac waveforms for which a non-integral number of cycles of data has been acquired may result in measurement errors due to the last partial cycle of acquired data. The instrument reduces this error by using a Hanning window function when making the measurement. If the measurement readings vary from sample to sample, try increasing the data acquisition time to reduce measurement error.

### Pulse Measurements (HP Model 66311B Only)

Use fetch queries to return all measurement data in the shortest time. The fetch functions do not trigger the acquisition of new measurement data, but are used to return different calculations from the data that was retrieved by the acquisition trigger. If you take a voltage measurement you can fetch only voltage data; if you take a current measurement you can fetch only current data, otherwise an error will occur.

The dc source has several measurement queries that return key parameters of pulse waveforms as shown in Figure 7-3.

## 7 - Programming the DC Source

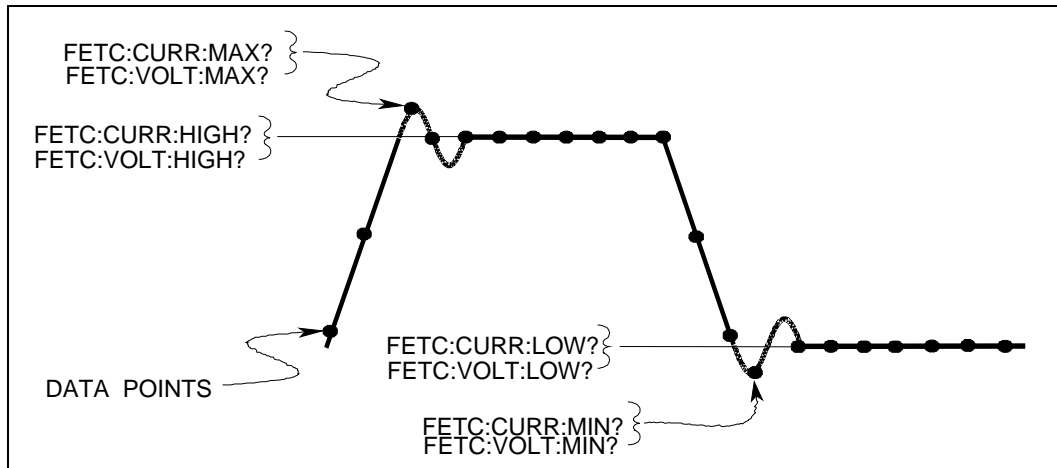

Figure 7-3. Measurement Commands Used to Return Pulse Data

### Minimum and Maximum Measurements

To return the maximum or minimum value of a pulse or ac waveform use:

```
FETCh:VOLTage:MAXimum? or  
FETCh:VOLTage:MINimum?  
FETCh:CURRent:MAXimum? or  
FETCh:CURRent:MINimum?
```

### High/Low Measurements

The value of the high level or low level of a pulse can also be measured. High and low level measurements are defined as follows: The instrument first measures the minimum and maximum data points of the pulse waveform. It then generates a histogram of the pulse waveform using 1024 bins between the maximum and minimum data points. The bin containing the most data points above the 50% point is the high bin. The bin containing the most data points below the 50% point is the low bin. The average of all the data points in the high bin is returned as the High level. The average of all the data points in the low bin is returned as the Low level. If no high or low bin contains more than 1.25% of the total number of acquired points, then the maximum or minimum value is returned by these queries.

To return the average value of the high bin, use:

```
FETCh:CURRent:HIGH? or  
FETCh:VOLTage:HIGH?
```

To return the average value of the low bin, use:

```
FETCh:CURRent:LOW? or  
FETCh:VOLTage:LOW?
```

### Returning All Measurement Data From the Data Buffer

The MEASure:ARRay and FETCh:ARRay queries return all data values of the instantaneous voltage or current buffer. No weighting function is applied when returning the raw data from the array. The commands are:

```
MEASure:ARRay:CURRent?  
MEASure:ARRay:VOLTage?
```

## Internally Triggered Measurements

You can use the data acquisition trigger system to synchronize the timing of the voltage and current data acquisition with a BUS or internal trigger source. Then use the FETCh commands to return different calculations from the data acquired by the measurement trigger.

### SCPI Triggering Nomenclature

As previously explained under "Triggering Output Changes", the dc source uses the following sequence name and alias for the measurement trigger system. This alias can be used instead of the sequence form.

Sequence Form	Alias
SEquence2	ACQuire

### Measurement Trigger System Model

Figure 7-4 is a model of the measurement trigger system. The rectangular boxes represent states. The arrows show the transitions between states. These are labeled with the input or event that causes the transition to occur.

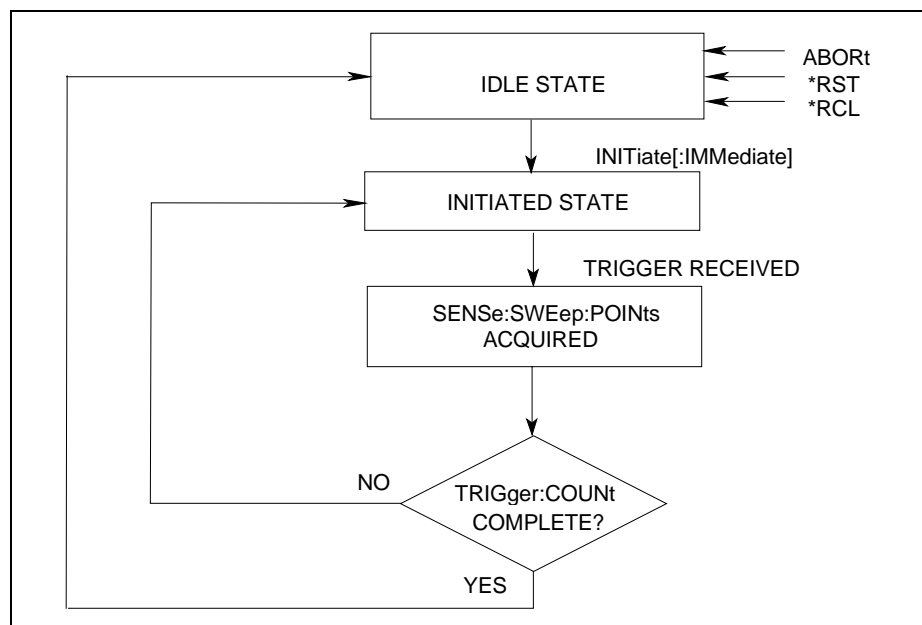

Figure 7-4. Model of Measurement Triggers

### Initiating the Measurement Trigger System

When the dc source is turned on, the trigger system is in the idle state. In this state, the trigger system ignores all triggers. Sending the following commands at any time returns the trigger system to the idle state:

```

ABORt
*RST
*RCL
  
```

## 7 - Programming the DC Source

The INITiate commands move the trigger system from the idle state to the initiated state. This enables the dc source to receive triggers. To initiate for a measurement trigger, use:

```
INITiate:SEquence2 or  
INITiate:NAME ACquire
```

After a trigger is received and the data acquisition completes, the trigger system will return to the idle state (unless multiple measurements are desired). Thus it will be necessary to initiate the system each time a triggered acquisition is desired.

---

**NOTE:** You cannot initiate measurement triggers continuously. Otherwise, the measurement data in the data buffer would continuously be overwritten by each triggered measurement.

---

### Selecting the Measurement Trigger Source

The trigger system is waiting for a trigger signal in the initiated state. Before you generate a trigger, you must select a trigger source. The following measurement trigger sources can be selected:

**BUS** - selects HP-IB bus triggers.  
**INTernal** - selects the dc source's output as the measurement trigger.

To select HP-IB bus triggers (group execute trigger, device trigger, or \*TRG command), use:

```
TRIGger:SEquence2:SOURce BUS or  
TRIGger:ACquire:SOURce BUS
```

To select internal triggers (measurements triggered off the output signal) use:

```
TRIGger:SEquence2:SOURce INTernal or  
TRIGger:ACquire:SOURce INTernal
```

### Generating Measurement Triggers

There is only one measurement converter in the dc source. Before you generate a measurement trigger, you must specify a measurement acquisition of either voltage or current. To specify a measurement acquisition use:

```
SENSE:FUNCTion "CURRent" or  
SENSE:FUNCTion "VOLTage"
```

### Single Triggers

After you specify the appropriate trigger source and measurement acquisition, you can generate triggers as follows:

**HP-IB Triggers** Send one of the following commands over the HP-IB:  
TRIGger:IMMEDIATE (not affected by the trigger source setting)  
\*TRG  
a group execute trigger

**Internal Triggers** To trigger off of the output signal, you must specify the output level that generates the trigger, the rising or falling edge of the slope, and a hysteresis to qualify trigger conditions. This is illustrated in figure 7-5.

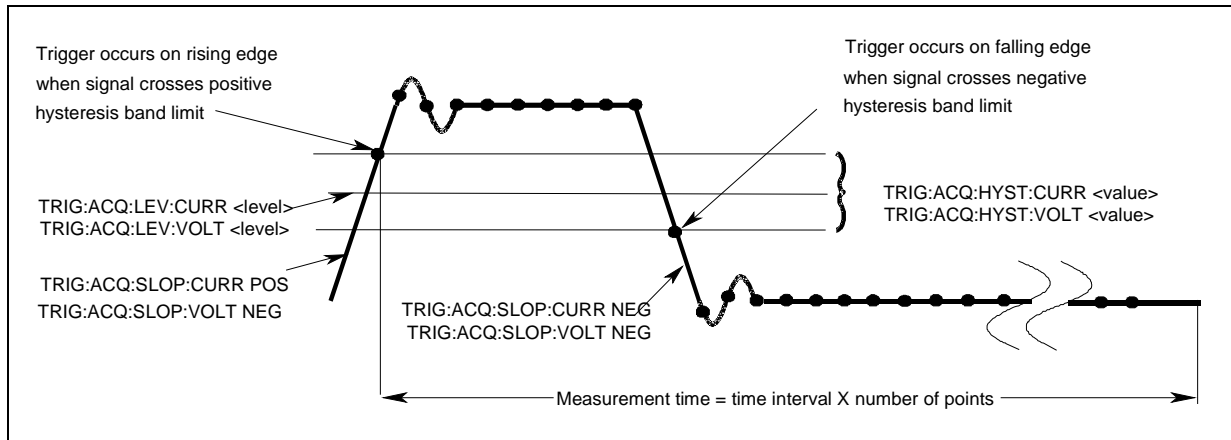

**Figure 7-5. Commands Used to Control Measurement Triggers**

To specify the **output level** that will generate triggers for both positive- and negative-going signals use:

```
TRIGger:SEquence2:LEVel:CURRent <value> or
TRIGger:ACQuire:LEVel:CURRent <value>
```

To specify the **slope** on which triggering occurs use the following commands. You can specify a POSitive, a NEGative, or EITHER type of slope.

```
TRIGger:SEquence2:SLOPe:CURRent <slope> or
TRIGger:ACQuire:SLOPe:CURRent <slope>
```

To specify a **hysteresis band** to qualify the positive- or negative-going signal use:

```
TRIGger:SEquence2:HYSTeresis:CURRent <value> or
TRIGger:ACQuire:HYSTeresis:CURRent <value>
```

---

**NOTE:** When using internal triggers, do not INITiate the measurement until after you have specified the slope, level, and hysteresis.

---

When the acquisition finishes, any of the FETCh queries can be used to return the results. Once the measurement trigger is initiated, if a FETCh query is sent before the data acquisition is triggered or before it is finished, the response data will be delayed until the trigger occurs and the acquisition completes. This may tie up the controller if the trigger condition does not occur immediately.

One way to wait for results without tying up the controller is to use the SCPI command completion commands. For example, you can send the \*OPC command after INITIALize, then occasionally poll the OPC status bit in the standard event status register for status completion while doing other tasks. You can also set up an SRQ condition on the OPC status bit going true, and do other tasks until an SRQ interrupt occurs.

## 7 - Programming the DC Source

### Multiple Triggers

As shown in Figure 7-6, the dc source also has the ability to set up several measurements in succession.

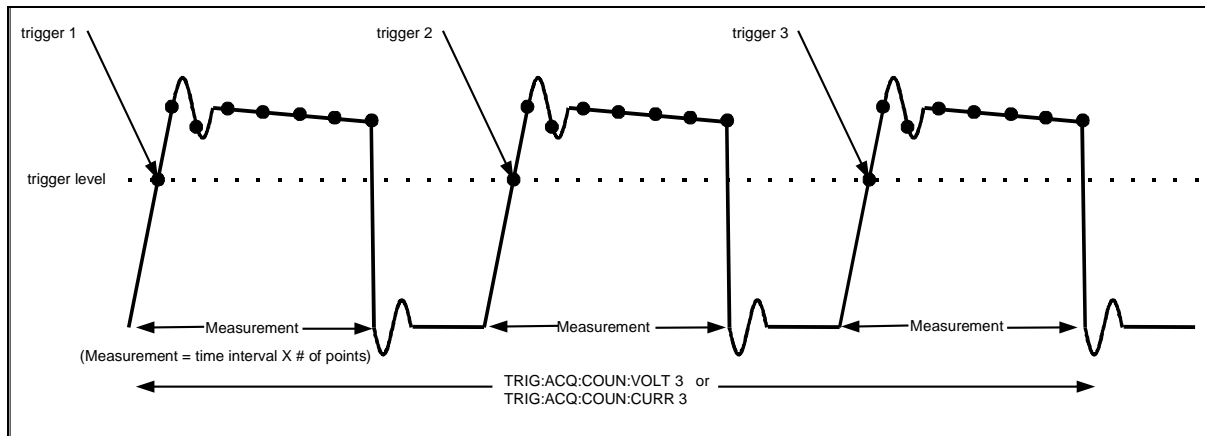

**Figure 7-6. Multiple Measurements**

To set up the trigger system for a number of sequential acquisitions use:

```
TRIGger:ACQuire:COUNT:CURRENT <number> or  
TRIGger:ACQuire:COUNT:VOLTage <number>
```

With this setup, the instrument performs each acquisition sequentially, storing the digitized readings in the internal measurement buffer. It is only necessary to initialize the measurement once at the start; after each completed acquisition the instrument will wait for the next valid trigger condition to start another. When all measurements complete, use FETCh commands to return the data.

By varying the measurement parameters, you can accurately measure specific portions of an output pulse. For example, if you set the measurement time to match the pulse width, you can measure just the high level of a specific number of output pulses. If you increase the measurement time to include the entire waveform, you will return measurement data based on the entire waveform. To calculate the correct time interval for your measurement, simply divide the desired measurement time by the number of points or samples in the measurement.

---

**NOTE:** The total number of data points cannot exceed 4096. This means that the count multiplied by the points in each measurement cannot exceed 4096; otherwise an error will occur.

---

### Pre-event and Post-event Triggering

When a measurement is initiated, the dc source continuously samples either the instantaneous output voltage or current. As shown in figure 7-7, you can move the block of data being read into the acquisition buffer with reference to the acquisition trigger. This permits pre-event or post-event data sampling.

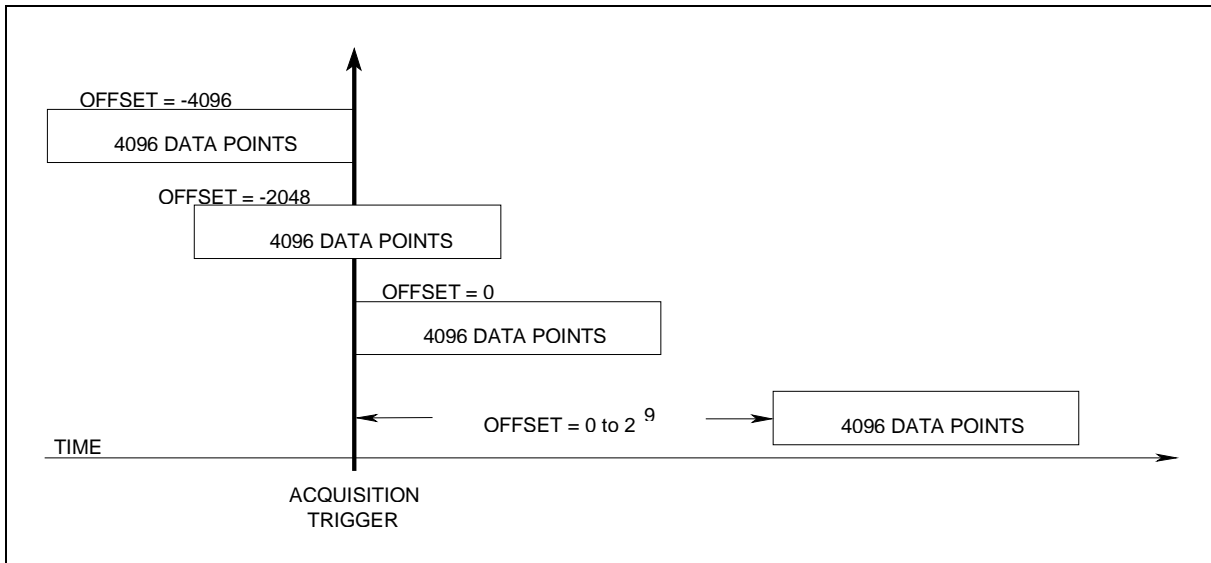

**Figure 7-7. Pre-event and Post-event Triggering**

To offset the beginning of the acquisition buffer relative to the acquisition trigger, use:

```
SENSe:SWEep:OFFSet:POINTs <offset>
```

The range for the offset is -4096 to 2,000,000,000 points. As shown in the figure, when the offset is negative, the values at the beginning of the data record represent samples taken prior to the trigger. When the value is 0, all of the values are taken after the trigger. Values greater than zero can be used to program a delay time from the receipt of the trigger until the data points that are entered into the buffer are valid. (Delay time = offset x sample period).

---

## Programming the Status Registers

You can use status register programming to determine the operating condition of the dc source at any time. For example, you may program the dc source to generate an interrupt (assert SRQ) when an event such as a current limit occurs. When the interrupt occurs, your program can then act on the event in the appropriate fashion.

Figure 7-7 shows the status register structure of the dc source. Table 7-1 defines the status bits. The Standard Event, Status Byte, and Service Request Enable registers and the Output Queue perform standard HP-IB functions as defined in the *IEEE 488.2 Standard Digital Interface for Programmable Instrumentation*. The Operation Status and Questionable Status registers implement functions that are specific to the dc source.

### Power-On Conditions

Refer to the \*RST command description in chapter 8 for the power-on conditions of the status registers.

## 7 - Programming the DC Source

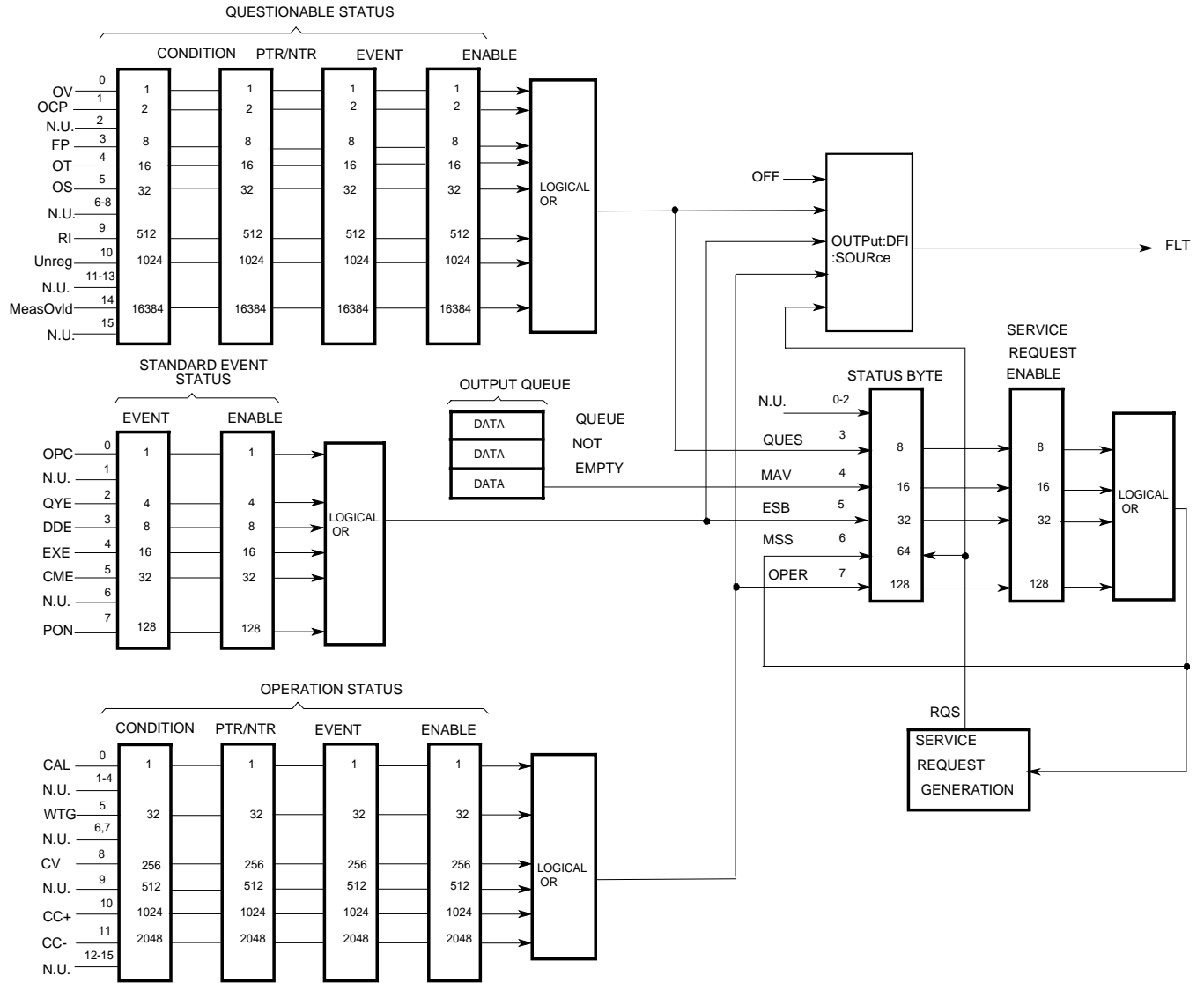

FIG4-6.GAL

Figure 7-7. DC Source Status Model



**Table 7-1. Bit Configurations of Status Registers**

Bit	Signal	Meaning
<b>Operation Status Group</b>		
0	CAL	The dc source is computing new calibration constants
5	WTG	The dc source is waiting for a trigger
8	CV	The dc source is in constant voltage mode
10	CC+	The dc source is in constant current mode
11	CC-	The dc source is in negative constant current mode
<b>Questionable Status Group</b>		
0	OV	The overvoltage protection has tripped
1	OCP	The overcurrent protection has tripped
3	FP	A front panel key has been depressed while in local mode
4	OT	The overtemperature protection has tripped
5	OS	An open sense lead has been detected
9	RI	The remote inhibit state is active
10	Unreg	The output is unregulated
14	MeasOvld	Current measurement exceeded capability of low range
<b>Standard Event Status Group</b>		
0	OPC	Operation complete
2	QYE	Query error
3	DDE	Device-dependent error
4	EXE	Execution error
5	CME	Command error
7	PON	Power-on
<b>Status Byte and Service Request Enable Registers</b>		
3	QUES	Questionable status summary bit
4	MAV	Message Available summary bit
5	ESB	Event Status Summary bit
6	MSS	Master Status Summary bit
	RQS	Request Service bit
7	OPER	Operation status summary bit

## Operation Status Group

The Operation Status registers record signals that occur during normal operation. As shown below, the group consists of a Condition, PTR/NTR, Event, and Enable register. The outputs of the Operation Status register group are logically-ORed into the OPERation summary bit (7) of the Status Byte register.

Register	Command	Description
Condition	STAT:OPER:COND?	A register that holds real-time status of the circuits being monitored. It is a read-only register.
PTR Filter	STAT:OPER:PTR <n>	A positive transition filter that functions as described under STAT:OPER:NTR PTR commands in chapter 8. It is a read/write register.
NTR Filter	STAT:OPER:NTR <n>	A negative transition filter that functions as described under STAT:OPER:NTR PTR commands in chapter 8. It is a read/write register.
Event	STAT:OPER:EVEN?	A register that latches any condition that is passed through the PTR or NTR filters. It is a read-only register that is cleared when read.
Enable	STAT:OPER:ENAB <n>	A register that functions as a mask for enabling specific bits from the Event register. It is a read/write register.

## 7 - Programming the DC Source

### Questionable Status Group

The Questionable Status registers record signals that indicate abnormal operation of the dc source. As shown in figure 7-7, the group consists of the same type of registers as the Status Operation group. The outputs of the Questionable Status group are logically-ORed into the QUEStionable summary bit (3) of the Status Byte register.

Register	Command	Description
Condition	STAT:QUES:COND?	A register that holds real-time status of the circuits being monitored. It is a read-only register.
PTR Filter	STAT:QUES:PTR <n>	A positive transition filter that functions as described under STAT:QUES:NTR   PTR commands in chapter 8. It is a read/write register.
NTR Filter	STAT:QUES:NTR <n>	A negative transition filter that functions as described under STAT:QUES:NTR   PTR commands in chapter 8. It is a read/write register.
Event	STAT:QUES:EVEN?	A register that latches any condition that is passed through the PTR or NTR filters. It is a read-only register that is cleared when read.
Enable	STAT:QUES:ENAB <n>	A register that functions as a mask for enabling specific bits from the Event register. It is a read/write register..

### Standard Event Status Group

This group consists of an Event register and an Enable register that are programmed by Common commands. The Standard Event event register latches events relating to instrument communication status (see figure 7-7). It is a read-only register that is cleared when read. The Standard Event enable register functions similarly to the enable registers of the Operation and Questionable status groups.

Command	Action
*ESE	programs specific bits in the Standard Event enable register.
*PSC ON	clears the Standard Event enable register at power-on.
*ESR?	reads and clears the Standard Event event register.

### The PON (Power On) Bit

The PON bit in the Standard Event event register is set whenever the dc source is turned on. The most common use for PON is to generate an SRQ at power-on following an unexpected loss of power. To do this, bit 7 of the Standard Event enable register must be set so that a power-on event registers in the ESB (Standard Event Summary Bit), bit 5 of the Service Request Enable register must be set to permit an SRQ to be generated, and \*PSC OFF must be sent. The commands to accomplish these conditions are:

```
*PSC OFF
*ESE 128
*SRE 32
```

### Status Byte Register

This register summarizes the information from all other status groups as defined in the *IEEE 488.2 Standard Digital Interface for Programmable Instrumentation*. See Table 7-1 for the bit configuration.

Command	Action
*STB?	reads the data in the register but does not clear it (returns MSS in bit 6)
serial poll	clears RQS inside the register and returns it in bit position 6 of the response.

## The MSS Bit

This is a real-time (unlatched) summary of all Status Byte register bits that are enabled by the Service Request Enable register. MSS is set whenever the dc source has one or more reasons for requesting service. \*STB? reads the MSS in bit position 6 of the response but does not clear any of the bits in the Status Byte register.

## The RQS Bit

The RQS bit is a latched version of the MSS bit. Whenever the dc source requests service, it sets the SRQ interrupt line true and latches RQS into bit 6 of the Status Byte register. When the controller does a serial poll, RQS is cleared inside the register and returned in bit position 6 of the response. The remaining bits of the Status Byte register are not disturbed.

## The MAV Bit and Output Queue

The Output Queue is a first-in, first-out (FIFO) data register that stores dc source-to-controller messages until the controller reads them. Whenever the queue holds one or more bytes, it sets the MAV bit (4) of the Status Byte register.

## Determining the Cause of a Service Interrupt

You can determine the reason for an SRQ by the following actions:

- |        |   |
|--------|---|
| Step 1 | Determine which summary bits are active. Use:<br>*STB? or serial poll   |
| Step 2 | Read the corresponding Event register for each summary bit to determine which events caused the summary bit to be set. Use:<br>STATUS:QUESTIONABLE:EVENT?<br>STATUS:OPERATION:EVENT?<br>ESR?<br>When an Event register is read, it is cleared. This also clears the corresponding summary bit.  |
| Step 3 | Remove the specific condition that caused the event. If this is not possible, the event may be disabled by programming the corresponding bit of the status group Enable register or NTR PTR filter. A faster way to prevent the interrupt is to disable the service request by programming the appropriate bit of the Service Request Enable register |

## Servicing Operation Status and Questionable Status Events

This example assumes you want a service request generated whenever the dc source switches to the CC (constant current) operating mode, or whenever the dc source's overvoltage, overcurrent, or overtemperature circuits have tripped. From figure 7-7, note the required path for a condition at bit 10 (CC) of the Operation Status register to set bit 6 (RQS) of the Status Byte register. Also note the required path for Questionable Status conditions at bits 0, 1, and 4 to generate a service request (RQS) at the Status Byte register. The required register programming is as follows:

## 7 - Programming the DC Source

- Step 1            Program the Operation Status PTR register to allow a positive transition at bit 10 to be latched into the Operation Status Event register, and allow the latched event to be summed into the Operation summary bit. Use:  
STATus:OPERation:PTR 1024;ENABle 1024
- Step 2            Program the Questionable Status PTR register to allow a positive transition at bits 0, 1, or 4 to be latched into the Questionable Status Event register, and allow the latched event to be summed into the Questionable summary bit. Use:  
STATus:QUESTionable:PTR 19;ENABle 19                    (1 + 2 + 16 = 19)
- Step 3            Program the Service Request Enable register to allow both the Operation and the Questionable summary bits from the Status Byte register to generate RQS. Use:  
\*SRE 136            (8 + 128 = 136)
- Step 4            When you service the request, read the event registers to determine which Operation Status and Questionable Status Event register bits are set, and clear the registers for the next event. Use:  
STATus:OPERation:EVENT;QUESTionable:EVENT?

### Monitoring Both Phases of a Status Transition

You can monitor a status signal for both its positive and negative transitions. For example, to generate RQS when the dc source either enters the CC+ (constant current) condition or leaves that condition, program the Operational Status PTR/NTR filter as follows:

```
STATus:OPERational:PTR 1024;NTR 1024
STATus:OPERational:ENABle 1024;*SRE 128
```

The PTR filter will cause the OPERational summary bit to set RQS when CC+ occurs. When the controller subsequently reads the event register with STATus:OPERational:EVENT?, the register is cleared. When CC+ subsequently goes false, the NTR filter causes the OPERational summary bit to again set RQS.

---

## Inhibit/Fault Indicator

The remote inhibit(INH) and discrete fault(FLT) indicators are implemented through the respective **INH** and **FLT** connections on the rear panel. Refer to Table A-2 for the electrical parameters. Refer to Appendix E for a programming example.

### Remote Inhibit (RI)

Remote inhibit is an external, chassis-referenced logic signal routed through the rear panel INH connection, which allows an external device to signal a fault. To select an operating modes for the remote inhibit signal, use:

```
OUTPut:RI:MODE LATCHing | LIVE | OFF
```

## Discrete Fault Indicator (DFI)

The discrete fault indicator is an open-collector logic signal connected to the rear panel FLT connection that can be used to signal external devices when a fault condition is detected. To select the internal fault source that drives this signal, use:

```
OUTPut:DFI:SOURce QUESTIONable | OPERATION | ESB | RQS | OFF
```

To enable or disable the DFI output, use:

```
OUTPut:DFI:STATE ON | OFF
```

## Using the Inhibit/Fault Port as a Digital I/O

You can configure the inhibit/fault port to provide a digital input/output to be used with custom digital interface circuits or relay circuits. As shipped from the factory, the port is shipped for inhibit/fault operation. You can change the configuration of the port to operate as a general-purpose digital input output port with the following command:

```
[SOURce:]DIGital:FUNCTION RIDFi | DIGio
```

The following table shows the pin assignments of the mating plug when used in RI/DFI mode as well as Digital I/O mode. Refer to Table A-2 for the electrical characteristics of the port.

Pin	FAULT/INHIBIT	DIGITAL I/O	Bit Weight
1	FLT Output	OUT 0	0
2	FLT Output	OUT 1	1
3	INH Input	IN/OUT 2	2
4	INH Common	Common	not programmable

To program the digital I/O port use:

```
[SOURce:]DIGital:DATA <data>
```

where the data is an integer from 0 to 7 that sets pins 1 to 3 according to their binary weight. Refer to the DIGital:DATA command for more information.



# Language Dictionary

---

## Introduction

This section gives the syntax and parameters for all the IEEE 488.2 SCPI commands and the Common commands used by the dc source. It is assumed that you are familiar with the material in chapter 6, which explains the terms, symbols, and syntactical structures used here and gives an introduction to programming. You should also be familiar with chapter 5, in order to understand how the dc source functions.

The programming examples are simple applications of SCPI commands. Because the SCPI syntax remains the same for all programming languages, the examples given for each command are generic.

<b>Syntax Forms</b>	Syntax definitions use the long form, but only short form headers (or "keywords") appear in the examples. Use the long form to help make your program self-documenting.
<b>Parameters</b>	Most commands require a parameter and all queries will return a parameter. The range for a parameter may vary according to the model of dc source. When this is the case, refer to the Specifications table in the Appendix A.
<b>Related Commands</b>	Where appropriate, related commands or queries are included. These are listed because they are either directly related by function, or because reading about them will clarify or enhance your understanding of the original command or query.
<b>Order of Presentation</b>	The dictionary is organized according to the following functions: calibration, display, measurement, output, status, system, trigger, and common commands. Both the subsystem commands and the common commands that follow are arranged in alphabetical order under each heading.

## Subsystem Commands

Subsystem commands are specific to functions. They can be a single command or a group of commands. The groups are comprised of commands that extend one or more levels below the root.

The subsystem command groups are arranged according to function: Calibration, Display, Measurement, Output, Status, System, and Trigger. Commands under each function are grouped alphabetically. Commands followed by a question mark (?) take only the query form. When commands take both the command and query form, this is noted in the syntax descriptions. Table 8-1 lists all of the subsystem commands in alphabetical order.

**Table 8-1. Subsystem Commands Syntax**

<b>ABORt</b>	Resets the trigger system to the Idle state
<b>CALibrate</b>	
<b>:CURRent</b>	
<b>[:SOURce]</b>	
<b>[:DC] [:POSitive]</b>	Calibrate positive output current and high current measurement range
<b>:MEASure</b>	
<b>[:DC] :LOWRange</b>	Calibrate low current measurement range
<b>:AC</b>	Calibrate ac current measurement circuits
<b>:DATA &lt;n&gt;</b>	Input a calibration measurement
<b>:LEVel &lt;level&gt;</b>	Advance to next calibration step (P1   P2)
<b>:PASSword &lt;n&gt;</b>	Set calibration password
<b>:SAVE</b>	Save new cal constants in non-volatile memory
<b>:STATE &lt;bool&gt; [,&lt;n&gt;]</b>	Enable or disable calibration mode
<b>:VOLTag</b>	
<b>[:DC]</b>	Calibrate output voltage and voltage readback
<b>:PROTection</b>	Begin voltage protection calibration sequence
<b>DISPlay</b>	
<b>[:WINDow]</b>	
<b>[:STATe] &lt;bool&gt;</b>	Enable/disable front panel display
<b>:MODE &lt;mode&gt;</b>	Set display mode (NORM   TEXT)
<b>:TEXT [:DATA] &lt;string&gt;</b>	Sets the text that is displayed
<b>INITiate</b>	
<b>[:IMMediate]</b>	
<b>:SEquence&lt;n&gt;</b>	Initiate a specific numbered sequence (1   2)
<b>:NAME &lt;name&gt;</b>	Initiate a specific named sequence (TRAN   ACQ)
<b>CONTInuous</b>	
<b>:SEquence1, &lt;bool&gt;</b>	Set continuous initialization
<b>:NAME TRANSient, &lt;bool&gt;</b>	Set continuous initialization
<b>MEASure   FETCh</b>	
<b>:ARRay</b>	
<b>:CURRent [:DC]?</b>	Returns the digitized instantaneous current
<b>:VOLTag [:DC]?</b>	Returns the digitized instantaneous voltage
<b>[:SCALar]</b>	
<b>:CURRent [:DC]?</b>	Returns dc current
<b>:ACDC?</b>	Returns the total rms current (ac+dc)
<b>:HIGH?</b>	Returns the HIGH level of a current pulse
<b>:LOW?</b>	Returns the LOW level of a current pulse
<b>:MAX?</b>	Returns maximum current
<b>:MIN?</b>	Returns minimum current
<b>:VOLTag [:DC]?</b>	Returns dc voltage
<b>:ACDC?</b>	Returns the total rms voltage (ac+dc)
<b>:HIGH?</b>	Returns the HIGH level of a voltage pulse
<b>:LOW?</b>	Returns the LOW level of a voltage pulse
<b>:MAX?</b>	Returns maximum voltage
<b>:MIN?</b>	Returns minimum voltage



Table 8-1. Subsystem Commands Syntax (continued)

<b>OUTPut</b>	
<b>[:STATe] &lt;bool&gt;</b>	Enables/disables the dc source output
<b>:TYPE [:CAPacitance] &lt;setting&gt;</b>	Sets output capacitor compensation (HIGH   LOW)
<b>:DFI</b>	
<b>[:STATe] &lt;bool&gt;</b>	Enables/disables the DFI output
<b>:SOURce &lt;source&gt;</b>	Selects event source (QUES   OPER   ESB   RQS   OFF)
<b>:PON</b>	
<b>:STATe &lt;state&gt;</b>	Set power-on state (*RST   RCL0)
<b>:PROTection</b>	
<b>:CLEar</b>	Reset latched protection
<b>:DELay &lt;n&gt;</b>	Delay after programming/before protection
<b>:RI</b>	
<b>:MODE &lt;mode&gt;</b>	Sets remote inhibit input (LATC   LIVE   OFF)
<b>SENSe</b>	
<b>:CURRent</b>	
<b>[:DC]</b>	
<b>RANGe [:UPPer] &lt;n&gt;</b>	Selects the high current measurement range
<b>:DETeCTOR &lt;detector&gt;</b>	Selects the current measurement detector (ACDC   DC)
<b>:FUNction &lt;function&gt;</b>	Configures the measurement sensor ("VOLT"   "CURR")
<b>:PROTection</b>	
<b>:STATe &lt;state&gt;</b>	Enables/disables open sense lead detection
<b>:SWEep</b>	
<b>:OFFSet</b>	
<b>:POINts &lt;n&gt;</b>	Defines the offset in the data sweep
<b>:POINts &lt;n&gt;</b>	Define the number of data points in a sweep
<b>:TINterval &lt;n&gt;</b>	Sets the digitizer sample spacing
<b>:WINDow [:TYPE] &lt;type&gt;</b>	Sets the measurement window function (HANN   RECT)
<b>[SOURce:]</b>	
<b>CURRent</b>	
<b>[:LEVel]</b>	
<b>[:IMMediate][:AMPLitude] &lt;n&gt;</b>	Sets the output current level
<b>:TRIGgered [:AMPLitude] &lt;n&gt;</b>	Sets the triggered output current level
<b>:PROTection</b>	
<b>:STATe &lt;bool&gt;</b>	Enables/disables current limit protection
<b>DIGital</b>	
<b>:DATA [:VALue] &lt;n&gt;</b>	Sets and reads the digital control port
<b>:FUNction &lt;function&gt;</b>	Configures digital control port (RIDF   DIG)
<b>VOLTage</b>	
<b>[:LEVel]</b>	
<b>[:IMMediate][:AMPLitude] &lt;n&gt;</b>	Sets the dc voltage level
<b>:TRIGgered [:AMPLitude] &lt;n&gt;</b>	Sets the transient voltage level
<b>:PROTection</b>	
<b>[:LEVel] &lt;n&gt;</b>	Sets the overvoltage protection threshold
<b>:STATe &lt;bool&gt;</b>	Enables/disables overvoltage protection

Table 8-1. Subsystem Commands Syntax (continued)

<b>STATus</b>	
<b>:PRESet</b>	Presets all enable and transition registers to power-on
<b>:OPERation</b>	
[:EVENT]?	Returns the value of the event register
:CONDition?	Returns the value of the condition register
:ENABle <n>	Enables specific bits in the Event register
:NTRansition<n>	Sets the Negative transition filter
:PTRansition<n>	Sets the Positive transition filter
<b>:QUESTionable</b>	
[:EVENT]?	Returns the value of the event register
:CONDition?	Returns the value of the condition register
:ENABle <n>	Enables specific bits in the Event register
:NTRansition<n>	Sets the Negative transition filter
:PTRansition<n>	Sets the Positive transition filter
<b>SYSTem</b>	
:ERRor?	Returns the error number and error string
:LANGUage <language>	Sets the programming language (SCPI   COMP)
:VERSion?	Returns the SCPI version number
:LOCal	Go to local mode (for RS-232 operation)
:REMote	Go to remote mode (for RS-232 operation)
:RWLock	Go to remote with local lockout (for RS-232 operation)
<b>TRIGger</b>	
<b>:SEquence2   :ACquire</b>	
[:IMMEDIATE]	Triggers the measurement immediately
:COUnT	
:CURRent <n>	Sets the number of sweeps per current measurement
:VOLTagE <n>	Sets the number of sweeps per voltage measurement
:HYSTeresis	
:CURRent <n>	Qualifies the trigger when measuring current
:VOLTagE <n>	Qualifies the trigger when measuring voltage
:LEVel	
:CURRent <n>	Sets the trigger level for measuring current
:VOLTagE <n>	Sets the trigger level for measuring voltage
:SLOPe	
:CURRent <slope>	Sets the triggered current slope (POS   NEG   EITH)
:VOLTagE <slope>	Sets the triggered voltage slope (POS   NEG   EITH)
:SOURce <source>	Sets the trigger source (BUS   INT)
<b>[:SEquence1   :TRANSient]</b>	
[:IMMEDIATE]	Triggers the output immediately
:SOURce <source>	Sets the trigger source (BUS)
<b>:SEquence1</b>	
:DEFine TRANSient	Sets or queries the SEQ1 name
<b>:SEquence2</b>	
:DEFine ACquire	Sets or queries the SEQ2 name

## Common Commands

Common commands begin with an \* and consist of three letters (command) or three letters and a ? (query). They are defined by the IEEE 488.2 standard to perform common interface functions. Common commands and queries are categorized under System, Status, or Trigger functions and are listed at the end of the chapter. The dc source responds to the following common commands:

**Table 8-2. Common Commands Syntax**

<b>*CLS</b>	Clear status
<b>*ESE &lt;n&gt;</b>	Standard event status enable
<b>*ESE?</b>	Return standard event status enable
<b>*ESR?</b>	Return event status register
<b>*IDN?</b>	Return instrument identification
<b>*OPC</b>	Enable "operation complete" bit in ESR
<b>*OPC?</b>	Return a "1" when operation complete
<b>*OPT?</b>	Return option number
<b>*PSC &lt;bool&gt;</b>	Power-on status clear state set/reset
<b>*PSC?</b>	Return power-on status clear state
<b>*RCL &lt;n&gt;</b>	Recall instrument state
<b>*RST</b>	Reset
<b>*SAV &lt;n&gt;</b>	Save instrument state
<b>*SRE &lt;n&gt;</b>	Set service request enable register
<b>*SRE?</b>	Return service request enable register
<b>*STB?</b>	Return status byte
<b>*TRG</b>	Trigger
<b>*TST?</b>	Perform selftest, then return result
<b>*WAI</b>	Hold off bus until all device commands done

## Programming Parameters

The following table lists the output programming parameters.

**Table 8-3. Output Programming Parameters**

Parameter	Value
[SOUR:]CURR[:LEV][:IMM] MAX and [SOUR:]CURR[:LEV]:TRIG MAX	3.0712
*RST Current Value	10% of MAX value
[SOUR:]VOLT[:LEV][:IMM]MAX and [SOUR:]VOLT[:LEV]:TRIG MAX	15.535
*RST Voltage Value	0 V
[SOUR:]VOLT:PROT[:LEV] MAX	22 V
*RST OVP Value	MAX
OUTP:PROT:DEL MAX	2,147,483.647
*RST Protection Delay Value	0.08 seconds
SENS:CURR:RANG (HP Model 66311B Only)	Low range = 0 – 20 mA High Range = 20 mA – MAX
*RST Current Range	Value MAX

---

## Calibration Commands

Calibration commands let you:

- ◆ Enable and disable the calibration mode
- ◆ Change the calibration password
- ◆ Calibrate the current and voltage programming and measurement, and store new calibration constants in nonvolatile memory.

---

**NOTE:** If calibration mode has not been enabled with CALibrate:STATe, programming the calibration commands will generate an error.

---

### CALibrate:CURRent

This command initiates the calibration of the positive dc output current as well as the high-range current measurement circuit.

<b>Command Syntax</b>	CALibrate:CURRent[:SOURce][:DC][:POSitive]
<b>Parameters</b>	None
<b>Examples</b>	CAL : CURR      CAL : CURR : SOUR : DC : POS
<b>Related Commands</b>	CAL:CURR:NEG

### CALibrate:CURRent:MEASure:LOWRange

HP 66311B only

This command initiates the calibration of the low-range current measurement circuit.

<b>Command Syntax</b>	CALibrate:CURRent:MEASure[:DC]:LOWRange
<b>Parameters</b>	None
<b>Examples</b>	CAL : CURR : MEAS
<b>Related Commands</b>	CAL:CURR

### CALibrate:CURRent:MEASure:AC

HP 66311B only

This command initiates the calibration of the high bandwidth (ac) measurement circuit.

<b>Command Syntax</b>	CALibrate:CURRent:MEASure:AC
<b>Parameters</b>	None
<b>Examples</b>	CAL : CURR : MEAS : AC

## CALibrate:DATA

This command enters a calibration value that you obtain by reading an external meter. You must first select a calibration level (with CALibrate:LEVel) for the value being entered.

<b>Command Syntax</b>	CALibrate:DATA<NRf>
<b>Parameters</b>	<external reading>
<b>Unit</b>	A (amperes)
<b>Examples</b>	CAL:DATA 3222.3 MA      CAL:DATA 5.000
<b>Related Commands</b>	CAL:STAT    CAL:LEV

## CALibrate:LEVel

This command selects the next point in the calibration sequence.

**P1:** the first calibration point

**P2:** the second calibration point

<b>Command Syntax</b>	CALibrate:LEVel <point>
<b>Parameters</b>	P1   P2
<b>Examples</b>	CAL:LEV P2

## CALibrate:PASSword

This command lets you change the calibration password. A new password is automatically stored in nonvolatile memory and does not have to be stored with CALibrate:SAVE.

If the password is set to 0, password protection is removed and the ability to enter the calibration mode is unrestricted.

<b>Command Syntax</b>	CALibrate:PASScode<NRf>
<b>Parameters</b>	<model number> (default)
<b>Examples</b>	CAL:PASS 6812      CAL:PASS 6.1994
<b>Related Commands</b>	CAL:SAV

## CALibrate:SAVE

This command saves any new calibration constants after a calibration procedure has been completed in nonvolatile memory. If CALibrate:STATe OFF is programmed without a CALibrate:SAVE, the previous calibration constants are restored..

<b>Command Syntax</b>	CALibrate:SAVE
<b>Parameters</b>	None
<b>Examples</b>	CAL:SAVE
<b>Related Commands</b>	CAL:PASS    CAL:STAT

## CALibrate:STATE

This command enables and disables calibration mode. The calibration mode must be enabled before the dc source will accept any other calibration commands.

The first parameter specifies the enabled or disabled state. The second parameter is the password. It is required if the calibration mode is being enabled and the existing password is not 0. If the password is not entered or is incorrect, an error is generated and the calibration mode remains disabled. The query statement returns only the state, not the password.

---

**NOTE:** Whenever the calibration state is changed from enabled to disabled, any new calibration constants are lost unless they have been stored with CALibrate:SAVE.

---

<b>Command Syntax</b>	CALibrate:STATE<bool>[,<NRf>]
<b>Parameters</b>	0   1   OFF   ON [,<password>]
<b>*RST Value</b>	OFF
<b>Examples</b>	CAL:STAT 1,6812 CAL:STAT OFF
<b>Query Syntax</b>	CALibrate:STATE?
<b>Returned Parameters</b>	<NR1>
<b>Related Commands</b>	CAL:PASS CAL:SAVE *RST

## CALibrate:VOLTage

This command initiates the calibration of the output voltage and the voltage readback circuit.

<b>Command Syntax</b>	CALibrate:VOLTage[:DC]
<b>Parameters</b>	None
<b>Examples</b>	CAL:VOLT CAL:VOLT:DC

## CALibrate:VOLTage:PROTection

This command calibrates the overvoltage protection (OV) circuit. The dc source automatically performs the calibration. CALibrate:VOLTage:PROTection is a sequential command that takes several seconds to complete.

<b>Command Syntax</b>	CALibrate:VOLTage:PROTection
<b>Parameters</b>	None
<b>Examples</b>	CAL:VOLT:PROT

## Display Commands

Display commands control the front panel display of the dc source.

### DISPlay

This command turns the front panel display on or off. When off, the front panel display is blank. The display annunciators are not affected by this command.

<b>Command Syntax</b>	DISPlay[:WINDow][:STATe] <bool>
<b>Parameters</b>	0   1   OFF   ON
<b>*RST Value</b>	ON
<b>Examples</b>	DISP ON          DISPLAY:STATE ON
<b>Query Syntax</b>	DISPlay[:WINDow][STATe]?
<b>Returned Parameters</b>	<NR1> 0 or 1
<b>Related Commands</b>	DISP:MODE    DISP:TEXT    *RST

### DISPlay:MODE

Switches the display between its normal instrument functions and a mode in which it displays text sent by the user. Text messages are defined with the DISPlay:TEXT command.

<b>Command Syntax</b>	DISPlay[:WINDow]:MODE <CRD>
<b>Parameters</b>	NORMal   TEXT
<b>*RST Value</b>	NORM
<b>Examples</b>	DISP:MODE NORM    DISPLAY:MODE TEXT
<b>Query Syntax</b>	DISPlay[:WINDow]:MODE?
<b>Returned Parameters</b>	<CRD>    NORMAL or TEXT
<b>Related Commands</b>	DISP    DISP:TEXT    *RST

### DISPlay:TEXT

This command sends character strings to the display when the display mode is set to TEXT. The character string is case-sensitive and must be enclosed in either single (') or double (") quotes. The display is capable of showing up to 14 characters. Strings exceeding 14 characters will be truncated.

<b>Command Syntax</b>	DISPlay[:WINDow]:TEXT [:DATA] <display_string>
<b>Parameters</b>	<display string>
<b>*RST Value</b>	null string
<b>Examples</b>	DISP:TEXT "DEFAULT_MODE"
<b>Query Syntax</b>	DISPlay[:WINDow]:TEXT?
<b>Returned Parameters</b>	<STR> (Last programmed text string)
<b>Related Commands</b>	DISP    DISP:MODE

## Format Commands

### FORMat

This command selects the data type and the type length for all array queries. Supported types are ASCII and REAL. When ASCII is selected, the response format for these queries is NR3 Numeric Response Data. This format is selected at \*RST. The only valid argument for <length> is 0, which means that the dc source selects the number of significant digits to be returned.

When REAL is selected, the array response format is Definite Length Arbitrary Block Response Data. The data within the Arbitrary Block is coded as IEEE single precision floating point, with 4 bytes per value. The second argument to the FORMat:DATA command specifies the number of bits in the returned data. Only the value 32 is permitted in dc source instruments. The byte order within a single value is determined by the FORMat:BORDER command. Definite Length Arbitrary Block Response Data format begins with a header that describes the number of data bytes in the response. The header begins with a pound sign, followed by a single non-zero digit that defines the number of digits in the block length, followed by the digits contained in the block.

For example: The response to the query "MEAS:ARR:CURR:[DC]? 1" which returns 45 numeric values would be as follows: '# '3' '1' '8' '0' <byte1> <byte2> ... <byte180> <newline>

<b>Command Syntax</b>	FORMat[:DATA] <CRD> [,length]
<b>Parameters</b>	ASCii   REAL
<b>*RST Value</b>	ASCii
<b>Examples</b>	FORM REAL
<b>Query Syntax</b>	FORMat?
<b>Returned Parameters</b>	<CRD>
<b>Related Commands</b>	FORM:BORD MEAS:ARR:CURR:DC? MEAS:ARR:VOLT:DC?

### FORMat:BORDER

This command selects whether the binary data is transferred in normal or swapped byte order. When NORMal is selected, the first byte sent is the sign bit and seven most significant bits of the exponent, and the last byte sent is the least significant byte of the mantissa. This ordering is generally used in big-endian controllers such as those that use Motorola processors.

When SWAPped is selected, the least significant byte of the mantissa is sent first and the sign bit and seven most significant bits of the exponent are sent last. This ordering is generally used in little-endian controllers such as those that use Intel processors.

<b>Command Syntax</b>	FORMat:BORDER <CRD>
<b>Parameters</b>	NORMal   SWAPped
<b>*RST Value</b>	NORMal
<b>Examples</b>	FORM:BORD SWAP
<b>Query Syntax</b>	FORMat:BORDER?
<b>Returned Parameters</b>	<CRD>
<b>Related Commands</b>	FORM[:DATA] MEAS:ARR:CURR:DC? MEAS:ARR:VOLT:DC



## Measurement Commands

Measurement commands consist of measure and sense commands.

**Measure commands** measure the output voltage or current. Measurements are performed by digitizing the instantaneous output voltage or current for a specified number of samples, storing the results in a buffer, and calculating the measured result. Two types of measurement commands are available: MEASure and FETCh. MEASure triggers the acquisition of new data before returning the reading; FETCh returns a reading computed from previously acquired data. If you take a voltage measurement, you can fetch only voltage data.

- ◆ Use MEASure when the measurement does not need to be synchronized with any other event.
- ◆ Use FETCh when it is important that the measurement be synchronized with either a trigger or with a particular part of the output waveform.

**Sense commands** control the current measurement range, the bandwidth detector of the dc source, and the data acquisition sequence.

### MEASure:ARRay:CURREnt? FETCh:ARRay:CURREnt?

These queries return an array containing the instantaneous output current in amperes. The output voltage or output current are digitized whenever a measure command is given or whenever an acquire trigger occurs. The time interval is set by SENSE:SWEep:TINTerval. The position of the trigger relative to the beginning of the data buffer is determined by SENSE:SWEep:OFFSet. The number of points returned is set by SENSE:SWEep:POINts.

<b>Query Syntax</b>	MEASure:ARRay:CURREnt[:DC]?
	FETCh:ARRay:CURREnt[:DC]?
<b>Parameters</b>	None
<b>Examples</b>	MEAS : ARR : CURR?      FETC : ARR : CURR?
<b>Returned Parameters</b>	<NR3> [,<NR3>]
<b>Related Commands</b>	SENS:SWE:TINT    SENS:SWE:OFFS    SENS:SWE:POIN

### MEASure:ARRay:VOLTage? FETCh:ARRay:VOLTage?

These queries return an array containing the instantaneous output voltage in volts. The output voltage or output current are digitized whenever a measure command is given or whenever an acquire trigger occurs. The time interval is set by SENSE:SWEep:TINTerval. The position of the trigger relative to the beginning of the data buffer is determined by SENSE:SWEep:OFFSet. The number of points returned is set by SENSE:SWEep:POINts.

<b>Query Syntax</b>	MEASure:ARRay:VOLTage[:DC]?
	FETCh:ARRay:VOLTage[:DC]?
<b>Parameters</b>	None
<b>Examples</b>	MEAS : ARR : VOLT?      FETC : ARR : VOLT?
<b>Returned Parameters</b>	<NR3> [,<NR3>]
<b>Related Commands</b>	SENS:SWE:TINT    SENS:SWE:OFFS    SENS:SWE:POIN

**MEASure:CURRent?**  
**FETCh:CURRent?**

These queries return the dc output current.

<b>Query Syntax</b>	MEASure[:SCALar]:CURRent[:DC]? FETCh[:SCALar]:CURRent[:DC]?
<b>Parameters</b>	None
<b>Examples</b>	MEAS : CURR? MEAS : CURR : DC?
<b>Returned Parameters</b>	<NR3>
<b>Related Commands</b>	MEAS:VOLT?

**MEASure:CURRent:ACDC?**  
**FETCh:CURRent:ACDC?**

HP Model 66311B Only

These queries return the ac+dc rms output current.

<b>Query Syntax</b>	MEASure[:SCALar]:CURRent:ACDC? FETCh[:SCALar]:CURRent:ACDC?
<b>Parameters</b>	None
<b>Examples</b>	MEAS : CURR : ACDC? FETC : CURR : ACDC?
<b>Returned Parameters</b>	<NR3>
<b>Related Commands</b>	MEAS:VOLT:ACDC?

**MEASure:CURRent:HIGH?**  
**FETCh:CURRent:HIGH?**

HP Model 66311B Only

These queries return the High level current of a current pulse waveform. The instrument first measures the minimum and maximum data points of the pulse waveform. It then generates a histogram of the pulse waveform using 1024 bins between the maximum and minimum data points. The bin containing the most data points above the 50% point is the high bin. The average of all the data points in the high bin is returned as the High level. If no high bin contains more than 1.25% of the total number of acquired points, then the maximum value is returned by these queries.

<b>Query Syntax</b>	MEASure[:SCALar]:CURRent:HIGH? FETCh[:SCALar]:CURRent:HIGH?
<b>Parameters</b>	None
<b>Examples</b>	MEAS : CURR : HIGH? FETC : CURR : HIGH?
<b>Returned Parameters</b>	<NR3>
<b>Related Commands</b>	MEAS:CURR:LOW? CALC:REF:HIGH

## MEASure:CURRent:LOW? FETCh:CURRent:LOW?

### HP Model 66311B Only

These queries return the Low level current of a current pulse waveform. The instrument first measures the minimum and maximum data points of the pulse waveform. It then generates a histogram of the pulse waveform using 1024 bins between the maximum and minimum data points. The bin containing the most data points below the 50% point is the low bin. The average of all the data points in the low bin is returned as the Low level. If no low bin contains more than 1.25% of the total number of acquired points, then the minimum value is returned by these queries.

<b>Query Syntax</b>	MEASure[:SCALar]:CURRent:LOW? FETCh[:SCALar]:CURRent:LOW?
<b>Parameters</b>	None
<b>Examples</b>	MEAS : CURR : LOW?            FETC : CURR : LOW?
<b>Returned Parameters</b>	<NR3>
<b>Related Commands</b>	MEAS:CURR:HIGH?    CALC:REF:LOW

## MEASure:CURRent:MAXimum? FETCh:CURRent: MAXimum?

### HP Model 66311B Only

These queries return the maximum output current.

<b>Query Syntax</b>	MEASure[:SCALar]:CURRent:MAXimum? FETCh[:SCALar]:CURRent:MAXimum?
<b>Parameters</b>	None
<b>Examples</b>	MEAS : CURR : MAX?            FETC : CURR : MAX?
<b>Returned Parameters</b>	<NR3>
<b>Related Commands</b>	MEAS:CURR:MIN?

## MEASure:CURRent:MINimum? FETCh:CURRent:MINimum?

### HP Model 66311B Only

These queries return the minimum output current.

<b>Query Syntax</b>	MEASure[:SCALar]:CURRent:MINimum? FETCh[:SCALar]:CURRent:MINimum?
<b>Parameters</b>	None
<b>Examples</b>	MEAS : CURR : MIN?            FETC : CURR : MIN?
<b>Returned Parameters</b>	<NR3>
<b>Related Commands</b>	MEAS:CURR:MAX?

## MEASure:VOLTage? FETCh:VOLTage?

These queries return the dc output voltage.

<b>Query Syntax</b>	MEASure[:SCALar]:VOLTage[:DC]? MEASure[:SCALar]:VOLTage[:DC]?
<b>Parameters</b>	None
<b>Examples</b>	MEAS:VOLT?      FETC:VOLT:DC?
<b>Returned Parameters</b>	<NR3>
<b>Related Commands</b>	MEAS:CURR?

## MEASure:VOLTage:ACDC? FETCh:VOLTage:ACDC?

HP Model 66311B Only

These queries return the ac+dc rms output voltage.

<b>Query Syntax</b>	MEASure[:SCALar]:VOLTage:ACDC? FETCh[:SCALar]:VOLTage:ACDC?
<b>Parameters</b>	None
<b>Examples</b>	MEAS:VOLT:ACDC?      FETC:VOLT:ACDC?
<b>Returned Parameters</b>	<NR3>
<b>Related Commands</b>	MEAS:CURR:ACDC?

## MEASure:VOLTage:HIGH? FETCh:VOLTage:HIGH?

HP Model 66311B Only

These queries return the High level voltage of a voltage pulse waveform. The instrument first measures the minimum and maximum data points of the pulse waveform. It then generates a histogram of the pulse waveform using 1024 bins between the maximum and minimum data points. The bin containing the most data points above the 50% point is the high bin. The average of all the data points in the high bin is returned as the High level. If no high bin contains more than 1.25% of the total number of acquired points, then the maximum value is returned by these queries.

<b>Query Syntax</b>	MEASure[:SCALar]:VOLTage:HIGH? FETCh[:SCALar]:VOLTage:HIGH?
<b>Parameters</b>	None
<b>Examples</b>	MEAS:VOLT:HIGH?      FETC:VOLT:HIGH?
<b>Returned Parameters</b>	<NR3>
<b>Related Commands</b>	MEAS:VOLT:LOW?    CALC:REF:HIGH

## MEASure:VOLTage:LOW? FETCh:VOLTage:LOW?

### HP Model 66311B Only

These queries return the Low level voltage of a voltage pulse waveform. The instrument first measures the minimum and maximum data points of the pulse waveform. It then generates a histogram of the pulse waveform using 1024 bins between the maximum and minimum data points. The bin containing the most data points below the 50% point is the low bin. The average of all the data points in the low bin is returned as the Low level. If no low bin contains more than 1.25% of the total number of acquired points, then the minimum value is returned by these queries.

<b>Query Syntax</b>	MEASure[:SCALar]:VOLTage:LOW? FETCh[:SCALar]:VOLTage:LOW?
<b>Parameters</b>	None
<b>Examples</b>	MEAS:VOLT:LOW?            FETC:VOLT:LOW?
<b>Returned Parameters</b>	<NR3>
<b>Related Commands</b>	MEAS:VOLT:HIGH?    CALC:REF:LOW

## MEASure:VOLTage:MAXimum? FETCh:VOLTage:MAXimum?

### HP Model 66311B Only

These queries return the maximum output voltage.

<b>Query Syntax</b>	MEASure[:SCALar]:VOLTage:MAXimum? FETCh[:SCALar]:VOLTage:MAXimum?
<b>Parameters</b>	None
<b>Examples</b>	MEAS:VOLT:MAX?            FETC:VOLT:MAX?
<b>Returned Parameters</b>	<NR3>
<b>Related Commands</b>	MEAS:VOLT:MIN?

## MEASure:VOLTage:MINimum? FETCh:VOLTage:MINimum?

### HP Model 66311B Only

These queries return the minimum output voltage..

<b>Query Syntax</b>	MEASure[:SCALar]:VOLTage:MINimum? FETCh[:SCALar]:VOLTage:MINimum?
<b>Parameters</b>	None
<b>Examples</b>	MEAS:VOLT:MIN?            FETC:VOLT:MIN?
<b>Returned Parameters</b>	<NR3>
<b>Related Commands</b>	MEAS:VOLT:MAX?

**SENSe:CURRent:DETEctor****HP Model 66311B Only**

This command lets you select the type of detector used for output current measurements. Two choices for detecting current measurements are available:

- ACDC** This is the preferred choice for all dynamic current measurements. When ACDC is selected, the measured output current includes the current that flows in the instrument's output capacitor. It is especially important to use ACDC detection when measuring pulse or other waveforms with frequency contents greater than several kilohertz.
- DC** Select *DC* only if you are making dc current measurements and you require a dc measurement offset accuracy better than 2mA on the High current measurement range. When DC is selected, the component of output current that is supplied by the instrument's output filter is not sensed. Note that this selection gives inaccurate results on current waveforms with frequency contents greater than several kilohertz.

---

**NOTE:** This command only applies to the High current measurement range.

---

**Command Syntax** SENSe:CURRent:DETEctor <detector>  
**Parameters** ACDC or DC  
**\*RST Value** ACDC  
**Examples** SENS:CURR:DET ACDC          SENS:CURR:DET DC  
**Query Syntax** SENSe:CURRent:DETEctor?  
**Returned Parameters** <CRD>

**SENSe:CURRent:RANGe****HP Model 66311B Only**

This command selects the dc current measurement range. The HP 6631B dc source has two current measurement ranges:

**High Range:** 0 through MAX (see Table 8-3)

**Low Range:** 0 through 0.02 A (all models)

The High range covers the full current measurement capability of the instrument. The Low range measures currents up to a maximum of 20 mA. This increases the low current measurement sensitivity for greater accuracy and resolution. The value that you program with SENSe:CURRent:RANGe must be the maximum current that you expect to measure. The instrument will select the range that gives the best resolution. The crossover value is 20 mA. When queried, the returned value is the maximum current that can be measured on the range that is presently set.

**Command Syntax** SENSe:CURRent[:DC]:RANGe[:UPPer] <NRf+>  
**Parameters** 0 through MAX (see table 8-3)  
**Unit** A (amperes)  
**\*RST Value** MAX (high range)  
**Examples** SENS:CURR:RANG 4.0  
**Query Syntax** SENSe:CURRent:RANGe?  
**Returned Parameters** <NR3>

**SENSe:FUNctIon**

This command configures the measurement sensor to measure either voltage or current when an acquire trigger is used. The query returns the function setting, either VOLT or CURR.

<b>Command Syntax</b>	SENSe:FUNctIon <function>
<b>Parameters</b>	"VOLTage"   "CURRent"
<b>Examples</b>	SENS:FUNC "VOLT"
<b>Query Syntax</b>	SENSe:FUNctIon?
<b>Returned Parameters</b>	<SRD>

**SENSe:PROtEction:STATe**

This command enables or disables the open sense lead detection.

<b>Command Syntax</b>	SENSe:PROtEction:STATe <bool>
<b>Parameters</b>	0   OFF   1   ON
<b>*RST Value</b>	1
<b>Examples</b>	SENS:PROT:STAT ON
<b>Query Syntax</b>	SENSe:PROtEct:STATe?
<b>Returned Parameters</b>	<NR3>

**SENSe:SWEEp:OFFSet:POINts**

This command defines the offset in a data sweep when an acquire trigger is used. Negative values represent data samples taken prior to the trigger. Positive values represent the delay after the trigger occurs but before the samples are acquired.

<b>Command Syntax</b>	SENSe:SWEEp:OFFSet:POINts <NRf+>
<b>Parameters</b>	-4095 through 2,000,000,000
<b>*RST Value</b>	0
<b>Examples</b>	SENS:SWE:OFFS:POIN -2047
<b>Query Syntax</b>	SENSe:SWEEp:OFFSet:POINts?
<b>Returned Parameters</b>	<NR3>
<b>Related Commands</b>	SENS:SWE:TINT    SENS:SWE:POIN    MEAS:ARR

**SENSe:SWEEp:POINts**

This command defines the number of points in a data sweep.

<b>Command Syntax</b>	SENSe:SWEEp:POINts<NRf+>
<b>Parameters</b>	1 through 4096
<b>*RST Value</b>	2048
<b>Examples</b>	SENS:SWE:POIN 1024
<b>Query Syntax</b>	SENSe:SWEEp:POINts?
<b>Returned Parameters</b>	<NR3>
<b>Related Commands</b>	SENS:SWE:TINT    SENS:SWE:OFFS    MEAS:ARR

**SENSe:SWEep:TINTerval**

This command defines the time period between samples

<b>Command Syntax</b>	SENSe:SWEep:TINTerval<NRf+>
<b>Parameters</b>	15.6 microseconds through 31200 seconds
<b>*RST Value</b>	15.6 microseconds
<b>Examples</b>	SENS:SWE:TINT 31.2E-6
<b>Query Syntax</b>	SENSe:SWEep:TINTerval?
<b>Returned Parameters</b>	<NR3>
<b>Related Commands</b>	SENS:SWE:POIN SENS:SWE:OFFS MEAS:ARR

**SENSe:WINDow**

This command sets the window function that is used in output measurement calculations. The following functions can be selected:

**HANNing** A signal conditioning window that reduces errors in dc and rms measurement calculations in the presence of periodic signals such as line ripple. It also reduces jitter when measuring successive pulse waveforms. The Hanning window multiplies each point in the measurement sample by the function  $\cos^4$ . Do not use the Hanning window when measuring single-shot pulse waveforms.

**RECTangular** A window that returns measurement calculations without any signal conditioning. This window may be used for pulse measurements where the exact period of the pulse waveform is known and the measurement interval can be set accordingly using the SENSe:SWEep:TINTerval command.

---

**NOTE:** Neither window function alters the instantaneous voltage or current data returned in the measurement array.

---

<b>Command Syntax</b>	SENSe:WINDow[:TYPE] <type>
<b>Parameters</b>	HANNing   RECTangular
<b>*RST Value</b>	HANNing
<b>Examples</b>	SENS:WIND RECT
<b>Query Syntax</b>	SENSe:WINDow[:TYPE]?
<b>Returned Parameters</b>	<CRD>



## Output Commands

Output commands consist of output and source commands.

**Output commands** control the output and digital port functions.

**Source commands** program the actual voltage, current, and digital port output.

### OUTPut

This command enables or disables the dc source output. The state of a disabled output is a condition of zero output voltage and a model-dependent minimum source current (see **\*RST**).

<b>Command Syntax</b>	OUTPut[:STATe] <bool>
<b>Parameters</b>	0   OFF   1   ON
<b>*RST Value</b>	0
<b>Examples</b>	OUTP 1          OUTPUT:STATE ON
<b>Query Syntax</b>	OUTPut[:STATe]?
<b>Returned Parameters</b>	<NR1>0 or 1
<b>Related Commands</b>	*RST   *RCL   *SAV

### OUTPut:DFI

This command enables or disables the discrete fault indicator (DFI) output from the dc source.

<b>Command Syntax</b>	OUTPut:DFI[:STATe] <bool>
<b>Parameters</b>	0   1   OFF   ON
<b>*RST Value</b>	OFF
<b>Examples</b>	OUTP:DFI 1          OUTP:DFI ON
<b>Query Syntax</b>	OUTPut:DFI[:STATe]?
<b>Returned Parameters</b>	0   1
<b>Related Commands</b>	OUTP:DFI:SOUR

### OUTPut:DFI:SOURce

This command selects the source for discrete fault indicator (DFI) events. The choices are:

<b>QUESTIONable</b>	selects the Questionable event summary bit (bit 3 of the Status Byte Register)
<b>OPERation</b>	selects the Operation Event summary bit (bit 7 of the Status Byte Register)
<b>ESB</b>	selects the Standard Event summary bit (bit 5 of the Status Byte Register)
<b>RQS</b>	selects the Request Service bit (bit 6 of the Status Byte Register)
<b>OFF</b>	selects no DFI source

<b>Command Syntax</b>	OUTP:DFI:SOUR <source>
<b>Parameters</b>	QUES   OPER   ESB   RQS   OFF
<b>*RST Value</b>	OFF
<b>Examples</b>	OUTP:DFI:SOUR OPER
<b>Query Syntax</b>	OUTPut:DFI:SOUR?
<b>Returned Parameters</b>	<CRD>
<b>Related Commands</b>	OUTP:DFI

**OUTPut:PON:STATe**

This command selects the power-on state of the dc source. This information is saved in non-volatile memory. The following states can be selected:

- RST** Sets the power-on state to \*RST. Refer to the \*RST command as described in this chapter for more information.
- RCL0** Sets the power-on state to \*RCL 0. Refer to the \*RCL command as described in this chapter for more information.

<b>Command Syntax</b>	OUTPut:PON:STATe <state>
<b>Parameters</b>	RST   RCL0
<b>Examples</b>	OUTP : PON : STAT RST
<b>Query Syntax</b>	OUTPut:PON:STATe?
<b>Returned Parameters</b>	<CRD>
<b>Related Commands</b>	*RST *RCL

**OUTPut:PROTection:CLEar**

This command clears the latch that disables the output when an overvoltage, overcurrent, overtemperature, or remote inhibit status condition is detected. All conditions that generate the fault must be removed before the latch can be cleared. The output is then restored to the state it was in before the fault condition occurred.

<b>Command Syntax</b>	OUTPut:PROTection:CLEar
<b>Parameters</b>	None
<b>Examples</b>	OUTP : PROT : CLE
<b>Related Commands</b>	OUTP:PROT:DEL *RCL *SAV

**OUTPut:PROTection:DELAy**

This command sets the time between the programming of an output change that produces a constant current condition (CC) and the recording of that condition by the Operation Status Condition register. The delay prevents the momentary changes in status that can occur during reprogramming from being registered as events by the status subsystem. Since the constant current condition is used to trigger overcurrent protection (OCP), this command also delays OCP. Overvoltage protection is not affected by this command.

<b>Command Syntax</b>	OUTPut:PROTection:DELAy <NRf+>
<b>Parameters</b>	0 to 2,147,483.647
<b>Unit</b>	seconds
<b>*RST Value</b>	0.08 (Normal)
<b>Examples</b>	OUTP : PROT : DEL 75E-1
<b>Query Syntax</b>	OUTPut:PROTection:DELAy?
<b>Returned Parameters</b>	<NR3>
<b>Related Commands</b>	OUTP:PROT:CLE *RCL *SAV

## OUTPut:RI:MODE

This command selects the mode of operation of the Remote Inhibit protection. The RI mode is stored in non-volatile memory. The following modes can be selected:

- LATChing** causes a TTL low signal on the INH input to disable the output. The only way to clear the latch is by sending OUTPut:PROTection:CLEAR while the INH input is false.
- LIVE** allows the INH input to disable the output in a non-latching manner. In other words, the output follows the state of the INH input. When INH is low true, the output is disabled. When INH is high the output is not affected.
- OFF** the INH input is disabled.

<b>Command Syntax</b>	OUTPut:RI:MODE <mode>
<b>Parameters</b>	LATChing   LIVE   OFF
<b>Examples</b>	OUTP:RI:MODE LIVE
<b>Query Syntax</b>	OUTPut:RI:MODE?
<b>Returned Parameters</b>	<CRD>
<b>Related Commands</b>	OUTP:PROT:CLE

## OUTPut:TYPE

This command programs the output compensation circuit. This circuit compensates the output of the dc source according to the input capacitance of the phone being tested. The circuit covers the following capacitance ranges:

**LOW mode:** 0  $\mu$ F to 12,000  $\mu$ F

**HIGH mode:** 5  $\mu$ F to 12,000  $\mu$ F

The HP 66311B is shipped with the output compensation set LOW mode. This mode provides the stable operation for all types of phones. The HIGH mode setting provides better transient response performance for phones that have input capacitances greater than 5  $\mu$ F. In this mode however, the operation of the dc source will be unstable when connected to phones that have input capacitances less than 5  $\mu$ F. (Units with option J01 are shipped with the compensation set to HIGH. The \*RST value is also HIGH.)

---

**NOTE:** If you set the output compensation to HIGH mode and you want the unit to power up in HIGH mode, you must first save the desired output settings in non-volatile memory location 0 with the \*SAV command. Then program the dc source to power up with the settings stored in memory location 0 with the OUTP:PON:STAT RCL0 command.

---

<b>Command Syntax</b>	OUTPut:TYPE[:CAPacitance] <setting>
<b>Parameters</b>	HIGH   LOW
<b>*RST Value</b>	LOW
<b>Examples</b>	OUTP:COMP HIGH
<b>Query Syntax</b>	OUTPput:TYPE[:CAPacitance]?
<b>Returned Parameters</b>	0   1



**[SOURce:]CURRent**

This command sets the immediate current level of the dc source. The immediate level is the current programmed for the output terminals.

<b>Command Syntax</b>	[SOURce:]CURRent[:LEVel][:IMMediate][:AMPLitude] <NRf+>
<b>Parameters</b>	see Table 8-3
<b>Default Suffix</b>	A (amperes)
<b>*RST Value</b>	10% of MAX
<b>Examples</b>	CURR 200 MA                      CURRENT:LEVEL 200 MA
<b>Query Syntax</b>	[SOURce:]CURRent[:LEVel][:IMMediate][:AMPLitude]?
<b>Returned Parameters</b>	<NR3>
<b>Related Commands</b>	CURR:TRIG

**[SOURce:]CURRent:PROTection:STATe**

This command enables or disables the overcurrent protection (OCP) function. If the dc source overcurrent protection function is enabled and the dc source goes into constant current operation, then the output is disabled and the Questionable Condition status register OC bit is set (see chapter 7 about programming the status registers). Note that the [SOURce:]CURRent command sets the current limit, which determines when the dc source goes into constant current operation. An overcurrent condition can be cleared with the OUTPut:PROTection:CLEar command after the cause of the condition is removed.

---

**NOTE:** Use OUTP:PROT:DEL to prevent momentary current limit conditions caused by programmed output changes from tripping the overcurrent protection.

---

<b>Command Syntax</b>	[SOURce:]CURRent:PROTection:STATe <bool>
<b>Parameters</b>	0   1   OFF   ON
<b>*RST Value</b>	OFF
<b>Examples</b>	CURR:PROT:STAT 0    CURRENT:PROTECTION:STATE OFF CURR:PROT:STAT 1    CURRENT:PROTECTION:STATE ON
<b>Query Syntax</b>	Syntax [SOURce:]CURRent:PROTection:STATe?
<b>Returned Parameters</b>	<NR1>0 or 1
<b>Related Commands</b>	OUTP:PROT:CLE    *RST

**[SOURce:]CURRent:TRIGger**

This command sets the pending triggered current level of the dc source. The pending triggered level is a stored current value that is transferred to the output terminals when a trigger occurs. In order for a trigger to occur, the trigger subsystem must be initiated (see the INITiate command in the trigger subsystem).

<b>Command Syntax</b>	[SOURce:]CURRent[:LEVel]:TRIGgered[:AMPLitude] <NRf+>
<b>Parameters</b>	see Table 8-3
<b>Default Suffix</b>	A ( amperes)
<b>*RST Value</b>	10% of MAX
<b>Examples</b>	CURR:TRIG 1    CURRENT:LEVEL:TRIGGERED 1
<b>Query Syntax</b>	SOURce:]CURRent[LEVel]:TRIGgered[:AMPLitude]?
<b>Returned Parameters</b>	<NR3>
<b>Related Commands</b>	INIT    CURR

**[SOURCE:]DIGital:DATA**

This command programs the digital control port when the port is configured for Digital I/O operation. The port has three signal pins and a digital ground pin. Pins 1 and 2 are output pins controlled by bits 0 and 1. Pin 3 is controlled by bit 2, and can be programmed to serve either as an input or an output. It normally serves as an output. Bit 2 must be programmed high to use pin 3 as an input. Pin 4 is the digital ground. Refer to the following chart for list of the programmable pin settings. The query returns the last programmed value in bits 0 and 1, and the value read at pin 3 in bit 2.

Program Value	Bit Configuration			Pin Setting			
	2	1	0	4	3	2	1
0	0	0	0	GND	Output	Lo	Lo
1	0	0	1	GND	Output	Lo	Hi
2	0	1	0	GND	Output	Hi	Lo
3	0	1	1	GND	Output	Hi	Hi
4	1	0	0	GND	Input	Lo	Lo
5	1	0	1	GND	Input	Lo	Hi
6	1	1	0	GND	Input	Hi	Lo
7	1	1	1	GND	Input	Hi	Hi

**Command Syntax** [SOURCE:]DIGital:DATA[:VALUE] <NRf>  
**Parameters** 0 to 7  
**\*RST Value** 0  
**Examples** DIG:DATA 7  
**Query Syntax** [SOURCE:]DIGital:DATA?  
**Returned Parameters** <NR1>

**[SOURCE:]DIGital:FUNCTION**

Configures the digital control port. The configuration setting is saved in non-volatile memory.

**RIDFi** Configures the port for Remote Inhibit/Discrete Fault Interrupt operation  
**DIGio** Configures the port for Digital input/output operation (see DIG:DATA)

**Command Syntax** [SOURCE:]DIGital:FUNCTION <CRD>  
**Parameters** RIDFi | DIGio  
**Examples** DIG:FUNC DIG  
**Query Syntax** [SOURCE:]DIGital:FUNC?  
**Returned Parameters** <CRD>

**[SOURCE:]VOLTage**

This command sets the output voltage level of the dc source.

**Command Syntax** [SOURCE:]VOLTage[:LEVEL][:IMMEDIATE][:AMPLITUDE]<NRf+>  
**Parameters** see Table 8-3  
**Default Suffix** V (volts)  
**\*RST Value** 0  
**Examples** VOLT 2                      VOLTAGE:LEVEL 200 MV  
**Query Syntax** [SOURCE:]VOLTage[:LEVEL][:IMMEDIATE][:AMPLITUDE]?  
**Returned Parameters** <NR3>  
**Related Commands** VOLT:TRIG

**[SOURce:]VOLTage:PROTection**

This command sets the overvoltage protection (OVP) level of the dc source. If the output voltage exceeds the OVP level, then the dc source output is disabled and the Questionable Condition status register OV bit is set (see chapter 7 about programming the status registers). An overvoltage condition can be cleared with the OUTP:PROT:CLE command after the condition that caused the OVP trip is removed. The OVP always trips with zero delay and is unaffected by the OUTP:PROT:DEL command. The OVP function can be disabled using the VOLT:PROT:STAT command.

<b>Command Syntax</b>	[SOURce:]VOLTage:PROTection[:LEVel]<NRf+>
<b>Parameters</b>	see Table 8-3
<b>Default Suffix</b>	V (volts)
<b>*RST Value</b>	MAX
<b>Examples</b>	VOLT:PROT 21.5            VOLT:PROT:LEV MAX
<b>Query Syntax</b>	[SOURce:]VOLTage:PROTection[:LEVel]?
<b>Returned Parameters</b>	<NR3>
<b>Related Commands</b>	OUTP:PROT:CLE    VOLT:PROT:STAT

**[SOURce:]VOLTage:PROTection:STATe**

This command enables or disables the overvoltage protection (OVP) function.

---

**CAUTION:**    Disabling the overvoltage protection function may cause excessive output voltages, such as can occur if remote sense leads are disconnected, to damage the equipment under test.

---

<b>Command Syntax</b>	[SOURce:]VOLTage:PROTection:STATe <bool>
<b>Parameters</b>	0   1   OFF   ON
<b>*RST Value</b>	OFF
<b>Examples</b>	VOLT:PROT:STAT 0    VOLTAGE:PROTECTION:STATE OFF VOLT:PROT:STAT 1    VOLTAGE:PROTECTION:STATE ON
<b>Query Syntax</b>	[SOURce:]VOLTage:PROTection:STATe?
<b>Returned Parameters</b>	<NR1>0 or 1
<b>Related Commands</b>	OUTP:PROT:CLE    *RST    VOLT:PROT

**[SOURce:]VOLTage:TRIGger**

This command sets the pending triggered voltage level of the dc source. The pending triggered level is a stored voltage value that is transferred to the output terminals when a trigger occurs. In order for a trigger to occur, the trigger subsystem must be initiated (see the INITiate command in the trigger subsystem).

<b>Command Syntax</b>	[SOURce:]VOLTage[:LEVel]:TRIGgered[:AMPLitude] <NRf+>
<b>Parameters</b>	see Table 8-3
<b>Default Suffix</b>	V (volts)
<b>*RST Value</b>	0
<b>Examples</b>	VOLT:TRIG 20            VOLTAGE:LEVEL:TRIGGERED 20
<b>Query Syntax</b>	[SOURce:]VOLTage[:LEVel]:TRIGgered[:AMPLitude]?
<b>Returned Parameters</b>	<NR3>
<b>Related Commands</b>	VOLT    *RST

## Status Commands

Status commands program the dc source status registers. The dc source has three groups of status registers; Operation, Questionable, and Standard Event. The Standard Event group is programmed with Common commands as described later in this section. The Operation and Questionable status groups each consist of the Condition, Enable, and Event registers and the NTR and PTR filters. Chapter 7 explains how to read specific register bits and use the information they return.

### STATus:PRESet

This command sets all defined bits in the Status Subsystem PTR registers and clears all bits in the subsystem NTR and Enable registers.

**Command Syntax** STATus:PRESet  
**Parameters** None  
**Examples** STAT:PRES STATUS:PRESET

**Table 8-4. Bit Configuration of Operation Status Registers**

Bit Position	15-12	11	10	9	8	7-6	5	4-1	0
Bit Name	not used	CC-	CC+	not used	CV	not used	WTG	not used	CAL
Bit Weight		2048	1024		256		32		1

CAL = The dc source is computing new calibration constants.  
 WTG = The dc source is waiting for a trigger.  
 CV = The dc source is operating in constant voltage mode.  
 CC+ = The dc source is operating in constant current mode.  
 CC = The dc source is operating in negative constant current mode.

### STATus:OPERation?

This query returns the value of the Operation Event register. The Event register is a read-only register, which holds (latches) all events that are passed by the Operation NTR and/or PTR filter. Reading the Operation Event register clears it.

**Query Syntax** STATus:OPERtion[:EVENT]?  
**Parameters** None  
**Returned Parameters** <NR1>(Register Value)  
**Examples** STAT:OPER? STATUS:OPERATIONAL:EVENT?  
**Related Commands** \*CLS STAT:OPER:NTR STAT:OPER:PTR

### STATus:OPERation:CONDition?

This query returns the value of the Operation Condition register. That is a read-only register, which holds the real-time (unlatched) operational status of the dc source.

**Query Syntax** STATus:OPERation:CONDition?  
**Parameters** None  
**Examples** STAT:OPER:COND? STATUS:OPERATION:CONDITION?  
**Returned Parameters** <NR1> (register value)





**Table 8-5. Bit Configuration of Questionable Status Registers**

Bit Position	15	14	13-11	10	9	8-6	5	4	3	2	1	0
Bit Name	not used	Meas Ovld	not used	Unreg	RI	not used	SD	OT	FP	not used	OCP	OV
Bit Weight		16384		1024	512		32	16	8		2	1

OV = overvoltage protection has tripped  
 OCP = overcurrent protection has tripped  
 FP = The front panel "Local" key has been depressed  
 OT = overtemperature protection has tripped  
 SD = broken sense lead detected  
 RI = remote inhibit is active  
 Unreg = output is unregulated  
 Meas Ovld = measurement overload

**STATUS:QUESTIONABLE?**

This query returns the value of the Questionable Event register. The Event register is a read-only register which holds (latches) all events that are passed by the Questionable NTR and/or PTR filter. Reading the Questionable Event register clears it.

**Query Syntax** STATUS:QUESTIONABLE[:EVENT]?  
**Parameters** None  
**Examples** STAT:QUES? STATUS:QUESTIONABLE:EVENT?  
**Returned Parameters** <NR1> (register value)  
**Related Commands** \*CLS STAT:QUES:ENAB STAT:QUES:NTR STAT:QUES:PTR

**STATUS:QUESTIONABLE:CONDITION?**

This query returns the value of the Questionable Condition register. That is a read-only register, which holds the real-time (unlatched) questionable status of the dc source.

**Query Syntax** STATUS:QUESTIONABLE:CONDITION?  
**Parameters** None  
**Examples** STAT:QUES:COND? STATUS:QUESTIONABLE:CONDITION?  
**Returned Parameters** <NR1> (register value)

**STATUS:QUESTIONABLE:ENABLE**

This command and its query set and read the value of the Questionable Enable register. This register is a mask for enabling specific bits from the Questionable Event register to set the questionable summary bit (QUES) of the Status Byte register. This bit (bit 3) is the logical OR of all the Questionable Event register bits that are enabled by the Questionable Status Enable register..

**Command Syntax** STATUS:QUESTIONABLE:ENABLE<NRf>  
**Parameters** 0 to 32767  
**Preset Value** 0  
**Examples** STAT:QUES:ENAB 20 STAT:QUES:ENAB 16  
**Query Syntax** STATUS:QUESTIONABLE:ENABLE?  
**Returned Parameters** <NR1> (register value)  
**Related Commands** STAT:QUES?

## STATus:QUEStionable:NTR

## STATus:QUEStionable:PTR

These commands allow you to set or read the value of the Questionable NTR (Negative-Transition) and PTR (Positive-Transition) registers. These registers serve as polarity filters between the Questionable Enable and Questionable Event registers to cause the following actions:

- ◆ When a bit of the Questionable NTR register is set to 1, then a 1-to-0 transition of the corresponding bit of the Questionable Condition register causes that bit in the Questionable Event register to be set.
- ◆ When a bit of the Questionable PTR register is set to 1, then a 0-to-1 transition of the corresponding bit in the Questionable Condition register causes that bit in the Questionable Event register to be set.
- ◆ If the same bits in both NTR and PTR registers are set to 1, then any transition of that bit at the Questionable Condition register sets the corresponding bit in the Questionable Event register.
- ◆ If the same bits in both NTR and PTR registers are set to 0, then no transition of that bit at the Questionable Condition register can set the corresponding bit in the Questionable Event register.

<b>Command Syntax</b>	STATus:QUEStionable:NTRansition<NRf> STATus:QUEStionable:PTRansition<NRf>
<b>Parameters</b>	0 to 32727
<b>Preset Value</b>	NTR register = 0; PTR register = 32727
<b>Examples</b>	STAT:QUES:NTR 16 STATUS:QUESTIONABLE:PTR 512
<b>Query Syntax</b>	STAT:QUES:NTR?STAT:QUES:PTR?
<b>Returned Parameters</b>	<NR1>(Register value)
<b>Related Commands</b>	STAT:QUES:ENAB

## System Commands

System commands control system functions that are not directly related to output control or measurement functions.

### SYSTem:ERRor?

This query returns the next error number followed by its corresponding error message string from the remote programming error queue. The queue is a FIFO (first-in, first-out) buffer that stores errors as they occur. As it is read, each error is removed from the queue. When all errors have been read, the query returns 0,NO ERROR. If more errors are accumulated than the queue can hold, the last error in the queue will be -350,TOO MANY ERRORS (see Appendix C for other error codes).

You can use the front panel Error key to read errors from the queue. Errors generated at the front panel are not put into the queue but appear immediately on the display.

<b>Query Syntax</b>	SYSTem:ERRor?
<b>Parameters</b>	None
<b>Returned Parameters</b>	<NR1> , <SRD>
<b>Examples</b>	SYST:ERR?SYSTEM:ERROR?

### SYSTem:LANGuage

This command switches the instrument between its SCPI command language and its compatibility language. The compatibility language is provided for emulation of older dc source systems and is described in Appendix B. Sending the command causes:

- ◆ The selected language to become active and to be stored in nonvolatile memory.
- ◆ The instrument to reset to its power-on state.

If the dc source is shut off, it will resume operation in the last-selected language when power is restored. Note that this command and query can be used regardless of the language that is presently selected.

<b>Command Syntax</b>	SYSTem:LANGuage<string>
<b>Parameters</b>	SCPI   COMPatibility
<b>Power-on Value</b>	<i>last selected language</i>
<b>Example</b>	SYST:LANG SCPI      SYSTEM:LANGUAGE COMPATIBILITY
<b>Query Syntax</b>	SYSTem:LANGuage?
<b>Returned Parameters</b>	<CRD>

### SYSTem:VERSion?

This query returns the SCPI version number to which the instrument complies. The returned value is of the form YYYY.V, where YYYY represents the year and V is the revision number for that year.

<b>Query Syntax</b>	SYSTem:VERSion?
<b>Parameters</b>	None
<b>Returned Parameters</b>	<NR2>
<b>Examples</b>	SYST:VERS?SYSTEM:VERSION?

**SYSTem:LOCal****For RS-232 Operation Only**

This command places the dc source in local mode during RS-232 operation. The front panel keys are functional.

<b>Command Syntax</b>	SYSTem:LOCal
<b>Parameters</b>	None
<b>Example</b>	SYST:LOC
<b>Related Commands</b>	SYST:REM    SYST:RWL

**SYSTem:REMote****For RS-232 Operation Only**

This command places the dc source in remote mode during RS-232 operation. This disables all front panel keys except the Local key. Pressing the Local key while in the remote state returns the front panel to the local state.

<b>Command Syntax</b>	SYSTem:REMote
<b>Parameters</b>	None
<b>Example</b>	SYST:REM
<b>Related Commands</b>	SYST:LOC    SYST:RWL

**SYSTem:RWLock****For RS-232 Operation Only**

This command places the dc source in remote mode during RS-232 operation. All front panel keys including the Local key are disabled. Use SYSTem:LOCAl to return the front panel to the local state.

<b>Command Syntax</b>	SYSTem:RWLock
<b>Parameters</b>	None
<b>Example</b>	SYST:RWL
<b>Related Commands</b>	SYST:REM    SYST:LOC

## Trigger Commands

Trigger commands consist of trigger and initiate commands.

**Initiate commands** initialize the trigger system. **Trigger commands** control the remote triggering of the dc source. Trigger commands (and Initiate commands) are referenced either by name or by number. The correspondence between names and numbers is:

Sequence Number	Sequence Name	Description
1 (the default)	TRANsient	Output transient trigger sequence
2	ACQuire	Measurement acquire trigger sequence

### ABORt

This command cancels any trigger actions presently in process. Pending trigger levels are reset to their corresponding immediate values. ABORt also resets the WTG bit in the Operation Condition Status register (see chapter 7 about programming the status registers). If INITiate:CONTinuous ON has been programmed, the trigger subsystem initiates itself immediately after ABORt, thereby setting WTG. ABORt is executed at power turn on and upon execution of \*RCL or RST.

<b>Command Syntax</b>	ABORt
<b>Parameters</b>	None
<b>Examples</b>	ABOR
<b>Related Commands</b>	INIT *RST *TRG TRIG

### INITiate:SEQuence

#### INITiate:NAME

INITiate commands control the initiation of both output and measurement triggers. When a trigger is enabled, an event on a selected trigger source causes the specified triggering action to occur. If the trigger subsystem is not enabled, all trigger commands are ignored.

<b>Command Syntax</b>	INITiate[:IMMediate]:SEQuence[ 1   2 ] INITiate[:IMMediate]:NAME<name>
<b>Parameters</b>	TRANsient   ACQuire (for INIT:NAME )
<b>Examples</b>	INIT:SEQ2 INIT:NAME TRAN
<b>Related Commands</b>	ABOR INIT:CONT TRIG TRIG:SEQ:DEF *TRG

### INITiate:CONTinuous:SEQuence1

#### INITiate:CONTinuous:NAME TRANsient

These commands control the output transient trigger system.

<b>1 or ON</b>	continuously initiates the output trigger system..
<b>0 or OFF</b>	turns off continuous triggering. In this state, the output trigger system must be initiated for each trigger using INITiate:SEQuence.

<b>Command Syntax</b>	INITiate:CONTinuous:SEQuence1 <bool> INITiate:CONTinuous:NAME TRANsient <bool>
<b>Parameters</b>	0   1   OFF   ON
<b>Examples</b>	INIT:CONT:SEQ ON INIT:CONT:NAME TRAN, 1
<b>Related Commands</b>	ABOR INIT TRIG TRIG:SEQ:DEF *TRG

## TRIGger

When the transient trigger subsystem is initiated, this command generates a trigger signal. The trigger will then:

1. Initiate a pending level change as specified by CURRent:TRIGger or VOLTage:TRIGger.
2. Clear the WTG bit in the Status Operation Condition register after both transient and acquire trigger sequences have completed. (WTG is the logical-or of both transient and acquire sequences.)
3. If INITiate:CONTinuous ON has been programmed, the trigger subsystem is immediately re-enabled for subsequent triggers. As soon as it is cleared, the WTG bit is again set to 1.

**Command Syntax** TRIGger[:SEquence1][:IMMEDIATE]  
TRIGger[:TRANsient][:IMMEDIATE]  
**Parameters** None  
**Examples** TRIG TRIG:IMM  
**Related Commands** ABOR CURR:TRIG INIT \*TRG VOLT:TRIG

## TRIGger:SOURce

This command is included for completeness. It selects the trigger source for transient triggers. Since BUS is the only trigger source for transient triggers, this command does not need to be used.

**BUS** HP-IB device, \*TRG, or <GET> (Group Execute Trigger)

**Command Syntax** TRIGger[:SEquence1]:SOURce<source>  
TRIGger[:TRANsient]:SOURce<source>  
**Parameters** BUS  
**\*RST Value** BUS  
**Examples** TRIG:SOUR BUS  
**Query Syntax** TRIGger[:SEquence1]:SOURce?  
TRIGger[:TRANsient]:SOURce?  
**Returned Parameters** <CRD>

## TRIGger:SEQuence2

### TRIGger:ACQuire

When the trigger subsystem is initiated, these commands generate a measurement trigger signal. The measurement trigger causes the dc source to measure the output voltage and current and store the results in a buffer.

**Command Syntax** TRIGger:SEQuence2[:IMMEDIATE]  
TRIGger:ACQuire[:IMMEDIATE]  
**Parameters** None  
**Examples** TRIG:SEQ2 TRIG:ACQ  
**Related Commands** TRIG:SOUR TRIG:SEQ2:DEF TRIG:SEQ2:COUN  
TRIG:SEQ2:LEV:VOLT TRIG:SEQ2:SLOP:CURR

## TRIGger:SEQuence2:COUNt:CURRent

### TRIGger:ACQuire:COUNt:CURRent

This command sets up a successive number of triggers for measuring current data. With this command, the trigger system needs to be initialized only once at the start of the acquisition period. After each completed measurement, the instrument waits for the next valid trigger condition to start another measurement. This continues until the count has completed.

<b>Command Syntax</b>	TRIGger:SEQuence2:COUNt:CURRent<NRf+> TRIGger:ACQuire:COUNt:CURRent<NRf+>
<b>Parameters</b>	1 to 100
<b>*RST Value</b>	1
<b>Examples</b>	TRIG:SEQ2:COUN:CURR 5    TRIG:ACQ:COUN:CURR 1
<b>Query Syntax</b>	TRIGger:SEQuence2:COUNt:CURRent? TRIGger:ACQuire:COUNt:CURRent?
<b>Returned Parameters</b>	<NR3>
<b>Related Commands</b>	TRIG:SEQ2    TRIG:ACQ

## TRIGger:SEQuence2:COUNt:VOLTage

### TRIGger:ACQuire:COUNt:VOLTage

This command sets up a successive number of triggers for measuring voltage data. With this command, the trigger system needs to be initialized only once at the start of the acquisition period. After each completed measurement, the instrument waits for the next valid trigger condition to start another measurement. This continues until the count has completed.

<b>Command Syntax</b>	TRIGger:SEQuence2:COUNt:VOLTage<NRf+> TRIGger:ACQuire:COUNt:VOLTage<NRf+>
<b>Parameters</b>	1 to 100
<b>*RST Value</b>	1
<b>Examples</b>	TRIG:SEQ2:COUN:VOLT 5 TRIG:ACQ:COUN:VOLT 1
<b>Query Syntax</b>	TRIGger:SEQuence2:COUNt:VOLTage? TRIGger:ACQuire:COUNt:VOLTage?
<b>Returned Parameters</b>	<NR3>
<b>Related Commands</b>	TRIG:SEQ2    TRIG:ACQ



## TRIGger:SEQuence2:HYSTeresis:CURRent TRIGger:ACQuire:HYSTeresis:CURRent

This command defines a band around the trigger level through which the signal must pass before an internal measurement can occur. The band limit above and below the trigger level is one half of the hysteresis value added to or subtracted from the trigger level.

For a positive trigger to occur, the excursion of an output waveform in the positive direction must start below the lower hysteresis band limit and pass through the upper hysteresis band limit. For a negative trigger to occur, the excursion of an output waveform in the negative direction must start above the upper hysteresis band limit and pass through the lower hysteresis band limit.

<b>Command Syntax</b>	TRIGger:SEQuence2:HYSTeresis:CURRent<NRf+> TRIGger:ACQuire:HYSTeresis:CURRent<NRf+>
<b>Parameters</b>	0 to MAX (see table 8-3)
<b>Unit</b>	A (amperes)
<b>*RST Value</b>	0
<b>Examples</b>	TRIG:SEQ2:HYST:CURR 0.5 TRIG:ACQ:HYST:CURR 0.5
<b>Query Syntax</b>	TRIGger:SEQuence2:HYSTeresis:CURRent? TRIGger:ACQuire:HYSTeresis:CURRent?
<b>Returned Parameters</b>	<NR3>
<b>Related Commands</b>	TRIG:SEQ2:HYST:VOLT    TRIG:SEQ2:LEV:CURR

## TRIGger:SEQuence2:HYSTeresis:VOLTage TRIGger:ACQuire:HYSTeresis:VOLTage

This command defines a band around the trigger level through which the signal must pass before an internal measurement can occur. The band limit above and below the trigger level is one half of the hysteresis value added to or subtracted from the trigger level.

For a positive trigger to occur, the excursion of an output waveform in the positive direction must start below the lower hysteresis band limit and pass through the upper hysteresis band limit. For a negative trigger to occur, the excursion of an output waveform in the negative direction must start above the upper hysteresis band limit and pass through the lower hysteresis band limit.

<b>Command Syntax</b>	TRIGger:SEQuence2:HYSTeresis:VOLTage<NRf+> TRIGger:ACQuire:HYSTeresis:VOLTage<NRf+>
<b>Parameters</b>	0 to MAX (see table 8-3)
<b>Unit</b>	V (volts)
<b>*RST Value</b>	0
<b>Examples</b>	TRIG:SEQ2:HYST:VOLT 2 TRIG:ACQ:HYST:VOLT 2
<b>Query Syntax</b>	TRIGger:SEQuence2:HYSTeresis:VOLTage? TRIGger:ACQuire:HYSTeresis:VOLTage?
<b>Returned Parameters</b>	<NR3>
<b>Related Commands</b>	TRIG:SEQ2:HYST:CURR    TRIG:SEQ2:LEV:VOLT

## TRIGger:SEQuence2:LEVel:CURRent

### TRIGger:ACQuire:LEVel:CURRent

This command sets the trigger level for internally triggered current measurements. A positive current trigger occurs when the current level changes from a value less than the lower hysteresis band limit to a value greater than the upper hysteresis band limit. Similarly, a negative current trigger occurs when the current level changes from a value greater than the upper hysteresis band limit to a value less than the lower hysteresis band limit.

<b>Command Syntax</b>	TRIGger:SEQuence2:LEVel:CURRent<NRf+> TRIGger:ACQuire:LEVel:CURRent<NRf+>
<b>Parameters</b>	0 to MAX (see table 8-3)
<b>Unit</b>	A (amperes)
<b>*RST Value</b>	0
<b>Examples</b>	TRIG:SEQ2:LEV:CURR 5      TRIG:ACQ:LEV:CURR MAX TRIG:ACQ:LEV 2
<b>Query Syntax</b>	TRIGger:SEQuence2:LEVel:CURRent? TRIGger:ACQuire:LEVel:CURRent?
<b>Returned Parameters</b>	<NR3>
<b>Related Commands</b>	TRIG:SEQ2:LEV:VOLT      TRIG:SEQ2:HYST:CURR

## TRIGger:SEQuence2:LEVel:VOLTage

### TRIGger:ACQuire:LEVel:VOLTage

This command sets the trigger level for internally triggered voltage measurements. A positive voltage trigger occurs when the voltage level changes from a value less than the lower hysteresis band limit to a value greater than the upper hysteresis band limit. Similarly, a negative voltage trigger occurs when the voltage level changes from a value greater than the upper hysteresis band limit to a value less than the lower hysteresis band limit.

<b>Command Syntax</b>	TRIGger:SEQuence2:LEVel:VOLTage<NRf+> TRIGger:ACQuire:LEVel:VOLTage<NRf+>
<b>Parameters</b>	0 to MAX (see table 8-3)
<b>Unit</b>	V (volts)
<b>*RST Value</b>	0
<b>Examples</b>	TRIG:SEQ2:LEV:VOLT 5      TRIG:ACQ:LEV:VOLT MAX      TRIG:ACQ:LEV 2
<b>Query Syntax</b>	TRIGger:SEQuence2:LEVel:VOLTage? TRIGger:ACQuire:LEVel:VOLTage?
<b>Returned Parameters</b>	<NR3>
<b>Related Commands</b>	TRIG:SEQ2:LEV:CURR      TRIG:SEQ2:HYST:VOLT

## TRIGger:SEQuence2:SLOPe:CURRent TRIGger:ACQuire:SLOPe:CURRent

This command sets the slope of an internally triggered current measurement.

**POSitive** triggering occurs on the rising edge.

**NEGative** triggering occurs on the falling edge.

**EITHer** triggering occurs on either edge.

<b>Command Syntax</b>	TRIGger:SEQuence2:SLOPe:CURRent<slope> TRIGger:ACQuire:SLOPe:CURRent<slope>
<b>Parameters</b>	EITHer   POSitive   NEGative
<b>*RST Value</b>	POSitive
<b>Examples</b>	TRIG:SEQ2:SLOP:CURR POS TRIG:ACQ:SLOP:CURR EITH
<b>Query Syntax</b>	TRIGger:SEQuence2:SLOPe:CURRent? TRIGger:ACQuire:SLOPe:CURRent?
<b>Returned Parameters</b>	<CRD>
<b>Related Commands</b>	TRIG:SEQ2:SLOP:VOLT

## TRIGger:SEQuence2:SLOPe:VOLTage TRIGger:ACQuire:SLOPe:VOLTage

This command sets the slope of an internally triggered voltage measurement.

**POSitive** triggering occurs on the rising edge.

**NEGative** triggering occurs on the falling edge.

**EITHer** triggering occurs on either edge.

<b>Command Syntax</b>	TRIGger:SEQuence2:SLOPe:VOLTage<slope> TRIGger:ACQuire:SLOPe:VOLTage<slope>
<b>Parameters</b>	EITHer   POSitive   NEGative
<b>*RST Value</b>	POSitive
<b>Examples</b>	TRIG:SEQ2:SLOP:VOLT POS TRIG:ACQ:SLOP:VOLT EITH
<b>Query Syntax</b>	TRIGger:SEQuence2:SLOPe:VOLTage? TRIGger:ACQuire:SLOPe:VOLTage?
<b>Returned Parameters</b>	<CRD>
<b>Related Commands</b>	TRIG:SEQ2:SLOP:CURR

**TRIGger:SEQuence2:SOURce**  
**TRIGger:ACQuire:SOURce**

These commands select the trigger source for measurement triggers as follows:

- BUS** HP-IB device, \*TRG, or <GET> (Group Execute Trigger)
- INTernal** trigger is generated internally when the measured waveform crosses the trigger level with the selected slope.

**Command Syntax** TRIGger:SEQuence2:SOURce<source>  
 TRIGger:ACQuire:SOURce<source>  
**Parameters** BUS | INTernal  
**\*RST Value** INTernal  
**Examples** TRIG:ACQ:SOUR BUS  
**Query Syntax** TRIGger:SEQuence2:SOURce?  
 TRIGger:ACQuire:SOURce?  
**Returned Parameters** <CRD>

**TRIGger:SEQuence1:DEFine**  
**TRIGger:SEQuence2:DEFine**

These commands define the names that are aliased to trigger sequences 1 and 2. The command accepts only ACQuire for sequence 2 and TRANsient for sequence 1 as predefined names. The query allows the user to query the instrument names aliased to sequences 1 and 2.

**Command Syntax** TRIGger:SEQuence1:DEFine TRANsient  
 TRIGger:SEQuence2:DEFine ACQuire  
**Parameters** TRANsient, ACQuire  
**Examples** SEQ1:DEF ACQ SEQ2:DEF TRAN  
**Query Syntax** TRIGger:SEQuence1:DEFine?  
 TRIGger:SEQuence2:DEFine?  
**Returned Parameters** <CRD>  
**Related Commands** TRIG:SEQ2:ACQ TRIG:SEQ1:TRAN

## Common Commands

### \*CLS

This command causes the following actions (see chapter 7 for the descriptions of all registers):

- ◆ Clears the following registers:
  - Standard Event Status
  - Operation Status Event
  - Questionable Status Event
  - Status Byte
- ◆ Clears the Error Queue
- ◆ If \*CLS immediately follows a program message terminator (<NL>), then the output queue and the MAV bit are also cleared.

**Command Syntax** \*CLS  
**Parameters** None

### \*ESE

This command programs the Standard Event Status Enable register bits. The programming determines which events of the Standard Event Status Event register (see \*ESR?) are allowed to set the ESB (Event Summary Bit) of the Status Byte register. A "1" in the bit position enables the corresponding event. All of the enabled events of the Standard Event Status Event Register are logically ORed to cause the Event Summary Bit (ESB) of the Status Byte Register to be set. The query reads the Standard Event The query reads the Standard Event Status Enable register.

**Table 8-6. Bit Configuration of Standard Event Status Enable Register**

Bit Position	7	6	5	4	3	2	1	0
Bit Name	PON	0	CME	EXE	DDE	QUE	0	OPC
Bit Weight	128	64	32	16	8	4	2	1
PON = Power-on has occurred CME = Command error EXE = Execution error				DDE = Device-dependent error QUE = Query error OPC = Operation complete				

**Command Syntax** \*ESE <NRf>  
**Parameters** 0 to 255  
**Power-On Value** (See \*PSC)  
**Examples** \*ESE 129  
**Query Syntax** \*ESE?  
**Returned Parameters** <NR1>(Register value)  
**Related Commands** \*ESR? \*PSC \*STB?

**\*ESR?**

This query reads the Standard Event Status Event register. Reading the register clears it. The bit configuration is the same as the Standard Event Status Enable register (see \*ESE).

**Query Syntax** \*ESR?  
**Parameters** None  
**Returned Parameters** <NR1>(Register binary value)  
**Related Commands** \*CLS \*ESE \*ESE? \*OPC

**\*IDN?**

This query requests the dc source to identify itself. It returns a string composed of four fields separated by commas.

<b>Query Syntax</b>	*IDN?		
<b>Returned Parameters</b>	<AARD>	<b>Field</b>	<b>Information</b>
		Hewlett-Packard	Manufacturer
		xxxxxA	model number followed by a letter suffix
		0	zero or the unit's serial number if available
		<A>.xx.xx	Revision levels of firmware.
<b>Example</b>	HEWLETT-PACKARD,66312A,0,A.00.01		

**\*OPC**

This command causes the instrument to set the OPC bit (bit 0) of the Standard Event Status register when the dc source has completed all pending operations. (See \*ESE for the bit configuration of the Standard Event Status register.) *Pending operations* are complete when:

- ◆ all commands sent before \*OPC have been executed. This includes overlapped commands. Most commands are sequential and are completed before the next command is executed. Overlapped commands are executed in parallel with other commands. Commands that affect output voltage, current or state, relays, and trigger actions are overlapped with subsequent commands sent to the dc source. The \*OPC command provides notification that all overlapped commands have been completed.
- ◆ all triggered actions are completed

\*OPC does not prevent processing of subsequent commands, but bit 0 will not be set until all pending operations are completed.

\*OPC? causes the instrument to place an ASCII "1" in the Output Queue when all pending operations are completed. Unlike \*OPC, \*OPC? prevents processing of all subsequent commands. It is intended to be used at the end of a command line so that the application program can then monitor the bus for data until it receives the "1" from the dc source Output Queue.

**Command Syntax** \*OPC  
**Parameters** None  
**Query Syntax** \*OPC?  
**Returned Parameters** <NR1> 1  
**Related Commands** \*OPC \*TRIG \*WAI

**\*OPT?**

This query requests the dc source to identify any options that are installed. Options are identified by number. A 0 indicates no options are installed.

**Query Syntax** \*OPT?  
**Returned Parameters** <AARD>

**\*PSC**

This command controls the automatic clearing at power-on of the Service Request Enable and the Standard Event Status Enable registers. The query returns the current state of \*PSC.

**\*PSC ON | 1** causes these registers to be cleared at power-on. This prevents a PON event from generating SRQ at power-on.

**\*PSC OFF | 0** causes the contents of the Standard Event Enable and Service Request Enable registers to be saved in nonvolatile memory and recalled at power-on. This allows a PON event to generate SRQ at power-on.

**Command Syntax** \*PSC <Bool>  
**Parameters** 0 | 1 | OFF | ON  
**Example** \*PSC 0            \*PSC 1  
**Query Syntax** \*PSC?  
**Returned Parameters** <NR1>0|1  
**Related Commands** \*ESE   \*SRE

**\*RCL**

This command restores the dc source to a state that was previously stored in memory with the \*SAV command to the specified location. All states are recalled with the following exceptions:

- ◆ the trigger system is set to the Idle state by an implied ABORt command (this cancels any uncompleted trigger actions)
- ◆ the calibration function is disabled by setting CAL:STATe to OFF

---

**NOTE:**            The device state stored in location 0 is automatically recalled at power turn-on when the OUTPut:PON:STATe is set to RCL0.

---

**Command Syntax** \*RCL <NRf>  
**Parameters** 0 | 1 | 2 | 3  
**Example** \*RCL 3  
**Related Commands** \*PSC   \*RST   \*SAV

**\*RST**

This command resets the dc source to a factory-defined state as defined in the following table. \*RST also forces an ABORt command.

**Table 8-8. \*RST Settings**

CAL:STAT	OFF	[SOUR:]CURR	10% of MAX*
DIG:DATA	0	[SOUR:]CURR:TRIG	10% of MAX*
DISP:STAT	ON	[SOUR:]CURR:PROT:STAT	OFF
DISP:MODE	NORM	[SOUR:]LIST:COUN	0
DISP:TEXT	“ “	[SOUR:]VOLT	0
INIT:CONT	OFF	[SOUR:]VOLT:TRIG	0
OUTP	OFF	[SOUR:]VOLT:PROT	MAX*
OUTP:DFI	OFF	[SOUR:]VOLT:PROT:STAT	ON
OUTP:DFI:SOUR	OFF	TRIG:ACQ:COUN:CURR	1
OUTP:PROT:DEL	.08	TRIG:ACQ:COUN:VOLT	1
OUTP:PROT:STAT	ON	TRIG:ACQ:HYST:CURR	0
OUTP:TYPE	LOW	TRIG:ACQ:HYST:VOLT	0
SENS:CURR:RANG	MAX	TRIG:ACQ:LEV:CURR	0
SENS:CURR:DET	ACDC	TRIG:ACQ:LEV:VOLT	0
SENS:FUNC	VOLT	TRIG:ACQ:SLOP:CURR	POS
SENS:SWE:OFFS:POIN	0	TRIG:ACQ:SLOP:VOLT	POS
SENS:SWE:POIN	2048	TRIG:ACQ:SOUR	INTERNAL
SENS:SWE:TINT	15.6 $\mu$ s	TRIG:TRAN:SOUR	BUS

**Command Syntax** \*RST  
**Parameters** None  
**Related Commands** \*PSC \*SAV

**\*SAV**

This command stores the present state of the dc source to the specified location in non-volatile memory. Up to 4 states can be stored. If a particular state is desired at power-on, it should be stored in location 0. It will then be automatically recalled at power turn-on if OUTPUT:PON:STATe is set to RCL0. \*RCL retrieves instrument states.

**Command Syntax** \*SAV <NRf>  
**Parameters** 0 | 1 | 2 | 3  
**Example** \*SAV 3  
**Related Commands** \*RCL \*RST



**\*SRE**

This command sets the condition of the Service Request Enable Register. This register determines which bits from the Status Byte Register (see \*STB for its bit configuration) are allowed to set the Master Status Summary (MSS) bit and the Request for Service (RQS) summary bit. A 1 in any Service Request Enable Register bit position enables the corresponding Status Byte Register bit and all such enabled bits then are logically ORed to cause Bit 6 of the Status Byte Register to be set.

When the controller conducts a serial poll in response to SRQ, the RQS bit is cleared, but the MSS bit is not. When \*SRE is cleared (by programming it with 0), the dc source cannot generate an SRQ to the controller. The query returns the current state of \*SRE.

**Command Syntax** \*SRE <NRf>  
**Parameters** 0 to 255  
**Power-on Value** see \*PSC  
**Example** \*SRE 20  
**Query Syntax** \*SRE?  
**Returned Parameters** <NR1> (register binary value)  
**Related Commands** \*ESE \*ESR \*PSC

**\*STB?**

This query reads the Status Byte register, which contains the status summary bits and the Output Queue MAV bit. Reading the Status Byte register does not clear it. The input summary bits are cleared when the appropriate event registers are read. The MAV bit is cleared at power-on, by \*CLS' or when there is no more response data available.

A serial poll also returns the value of the Status Byte register, except that bit 6 returns Request for Service (RQS) instead of Master Status Summary (MSS). A serial poll clears RQS, but not MSS. When MSS is set, it indicates that the dc source has one or more reasons for requesting service.

**Table 8-7. Bit Configuration of Status Byte Register**

Bit Position	7	6	5	4	3	2	1	0
Bit Name	OPER	MSS (RQS)	ESB	MAV	QUES	0	0	0
Bit Weight	128	64	32	16	8	4	2	1
ESB = Event status byte summary MAV = Message available MSS = Master status summary				OPER = Operation status summary QUES = Questionable status summary RQS = Request for service				

**Query Syntax** \*STB?  
**Returned Parameters** <NR1>(Register binary value)

## 8 – Language Dictionary

### **\*TRG**

This common command generates a trigger when the trigger subsystem has BUS selected as its source. The command has the same affect as the Group Execute Trigger (<GET>) command.

In RS-232 mode, this command emulates some of the functionality of the IEEE-488 Group Execute Trigger command.

<b>Command Syntax</b>	*TRG
<b>Parameters</b>	None
<b>Related Commands</b>	ABOR INIT TRIG[:IMM] <GET>

### **\*TST?**

This query causes the dc source to do a self-test and report any errors. 0 indicates that the dc source passed self-test. 1 indicates that one or more tests failed. Selftest errors are written to the error queue (see Appendix C).

<b>Query Syntax</b>	TST?
<b>Returned Parameters</b>	<NR1>

### **\*WAI**

This command instructs the dc source not to process any further commands until all pending operations are completed. "Pending operations" are as defined under the \*OPC command. \*WAI can be aborted only by sending the dc source an HP-IB DCL (Device Clear) command.

<b>Command Syntax</b>	WAI?
<b>Parameters</b>	None
<b>Related Commands</b>	*OPC*OPC?

## Additional Commands

The following commands are added to the language dictionary to provide compatibility for the Fluke PM2811 Power Supply. These commands will only work when the SYSTEM LANGUAGE is set to SCPI.

### INSTrument:STATe

This command enables or disables the dc source output. The state of a disabled output is a condition of zero output voltage and a model-dependent minimum source current (see \*RST).

<b>Command Syntax</b>	INSTrument:STATe <bool>
<b>Parameters</b>	0   OFF   1   ON
<b>*RST Value</b>	0
<b>Examples</b>	INST:STAT 1      INSTRUMENT:STATE ON
<b>Query Syntax</b>	INSTrument[:STATe]?
<b>Returned Parameters</b>	<NR1> 0 or 1
<b>Equivalent SCPI Command</b>	OUTPut[:STATe]

### OUTPut:PROTection:TRIPped?

This query reports if any OV (overvoltage), OCP (overcurrent protection), OT (over temperature), or RI (remote inhibit) status bit is set. 0 = bit is not set; 1 = bit is set.

<b>Query Syntax</b>	OUTPut:PROTection:TRIPped?
<b>Returned Parameters</b>	<NR1> 0 or 1
<b>Examples</b>	OUTP:PROT:TRIP?
<b>Equivalent SCPI Command</b>	STATus:QUEStionable:CONDition?

### CURRent:LIMit:HIGH?

This query returns the maximum rated current of the instrument.

<b>Query Syntax</b>	[SOURce:]CURRent:LIMit:HIGH?
<b>Returned Parameters</b>	<NRf>
<b>Examples</b>	CURR:LIM:HIGH?
<b>Equivalent SCPI Command</b>	[SOURce:]CURRent? MAX

### CURRent:LIMit:LOW?

This query returns the minimum rated current of the instrument.

<b>Query Syntax</b>	[SOURce:]CURRent:LIMit:LOW?
<b>Returned Parameters</b>	<NRf>
<b>Examples</b>	CURR:LIM:LOW?
<b>Equivalent SCPI Command</b>	[SOURce:]CURRent? MIN

### **CURRent:PROTection:TRIPped?**

This query reports if the OCP (overcurrent protection) status bit is set. 0 = bit is not set; 1 = bit is set.

<b>Query Syntax</b>	[SOURce:]CURRent:PROTection:TRIPped?
<b>Returned Parameters</b>	<NR1> 0 or 1
<b>Examples</b>	CURR:PROT:TRIP?
<b>Equivalent SCPI Command</b>	STATus:QUEStionable:CONDition?

### **VOLTage:LIMit:HIGH?**

This query returns the maximum rated voltage of the instrument.

<b>Query Syntax</b>	[SOURce:]VOLTage:LIMit:HIGH?
<b>Returned Parameters</b>	<NRf>
<b>Examples</b>	VOLT:LIM:HIGH?
<b>Equivalent SCPI Command</b>	[SOURce:]VOLTage? MAX

### **VOLTage:LIMit:LOW?**

This query returns the minimum rated voltage of the instrument.

<b>Query Syntax</b>	[SOURce:]VOLTage:LIMit:LOW?
<b>Returned Parameters</b>	<NRf>
<b>Examples</b>	VOLT:LIM:LOW?
<b>Equivalent SCPI Command</b>	[SOURce:]VOLTage? MIN

### **VOLTage:PROTection:TRIPped?**

This query reports if the OV (overvoltage protection) status bit is set. 0 = bit is not set; 1 = bit is set.

<b>Query Syntax</b>	[SOURce:]VOLTage:PROTection:TRIPped?
<b>Returned Parameters</b>	<NR1> 0 or 1
<b>Examples</b>	VOLT:PROT:TRIP?
<b>Equivalent SCPI Command</b>	STATus:QUEStionable:CONDition?

## Specifications

### Specifications

Table A-1 lists the specifications of the dc source. Unless otherwise noted, specifications are warranted over the ambient temperature range of 0 to 55 °C. Specifications apply with typical cellular phone capacitive loads from 0 $\mu$ F to 12,000 $\mu$ F. Sensing is at the rear terminals of the power supply after a 30-minute warm-up period. Sense terminals are externally jumpered to their respective output terminals.

**Table A-1. Performance Specifications**

Parameter		HP 66111A	HP 66311B
<b>Output Ratings</b>	Voltage: Current: Peak Current:	0 – 15 V 0 – 3 A <sup>1</sup> 5 A <sup>2</sup>	0 – 15 V 0 – 3 A <sup>1</sup> 5 A <sup>2</sup>
<b>Programming Accuracy</b> (@ 25°C $\pm$ 5°C)	Voltage: 0.05% + +Current: 0.05% +	10 mV 1.33 mA	10 mV 1.33 mA
<b>DC Measurement Accuracy</b> (via HP-IB or front panel meters with respect to actual output @ 25°C $\pm$ 5°C)	Voltage: 0.03% + <u>High Current range</u> +20 mA to +rated I: 0.2% + –20 mA to – rated I: 0.2% + <u>Low Current range</u> –20 mA to +20 mA: 0.1% +	5 mV <sup>3</sup> 9 mA 9 mA NA	5 mV <sup>3</sup> 0.5 mA <sup>4</sup> 1.1 mA 2.5 $\mu$ A
<b>Ripple and Noise</b> (in the range of 20 Hz to 20 MHz with outputs ungrounded or with either terminal grounded)	Voltage (rms/p-p): Current (rms):	1 mV/6 mV <sup>5</sup> 2 mA	
<b>Load Regulation</b> (change in output voltage or current for any load change within ratings)	Voltage: Current:	2 mV 0.75 mA	
<b>Line Regulation</b> (change in output voltage or current for any line change within ratings)	Voltage: Current:	0.5 mV 0.75 mA	
<b>Transient Response Time</b> (For the output voltage to recover to 20 mV <i>below</i> its final value. Applies to the negative portion of the output voltage transient waveform following a 0.1 to 1.5 A load change in the High Mode compensation range.)		< 35 $\mu$ s	

<sup>1</sup> From 45° to 55° average current derates linearly from 3 A to 2.5 A. All other specifications are unaffected.

<sup>2</sup> Peak current for up to a 7 millisecond time period. Average current over 11.7 milliseconds cannot exceed 3 A.

<sup>3</sup> Specification applies for output voltages greater than 10mV.

<sup>4</sup> Applies with current detector set to DC. In ACDC mode the offset is 4 times the specified value for +current and 2.6 mA for negative current.

<sup>5</sup> Specification is for phone capacitance greater than 5 $\mu$ F.

## Supplemental Characteristics

Table A-2 lists the supplemental characteristics, which are not warranted but are descriptions of typical performance determined either by design or type testing.

**Table A-2. Supplemental Characteristics**

Parameter		HP 66111A	HP 66311B
<b>Average Current Measurement Resolution</b>	High Range: Low Range:	3.5 mA NA	213 $\mu$ A 0.6 $\mu$ A
<b>Readback Accuracy Temperature Coefficient</b> (change/C°)	Voltage: 0.01% + Current (dc): 0.02% + Current (acdc): 0.05% + Current (low range): 0.01% +	300 $\mu$ V 15 $\mu$ A NA NA	300 $\mu$ V 15 $\mu$ A 120 $\mu$ A 0.3 $\mu$ A
<b>Maximum Current Measurement</b>		7 A	
<b>Output Programming Range</b>	Voltage: Current: OVP:	0 – 15.535 V 0 – 3.0712 A 22 V	
<b>Average Programming Resolution</b>	Voltage: Current: OVP:	3.75 mV 0.67 mA 100 mV	
<b>Programming Accuracy Temperature Coefficient</b> (change/C°)	Voltage: 0.01% + Current: 0.01% + OVP: 0.015% +	0.5 mV 15 $\mu$ A 4 mV	
<b>OVP Accuracy</b>	2.4 % +	240 mV	
<b>Drift<sup>2</sup></b>	Voltage: 0.01% + Current: 0.01% +	1 mV 30 $\mu$ A	
<b>Sink Current</b>		- 2 A @ 7.5 V <sup>1</sup>	
<b>Output Voltage Rise/Fall Time</b> (for a 10 – 90% or 90 – 10% change of the total excursion)		< 200 $\mu$ s	
<b>Output Voltage Settling Time</b> (time to settle within 1 LSB or 0.025% times the rated voltage of the final value)		2 ms	
<b>Dynamic Measurement Accuracy</b>	Instantaneous Voltage: Instantaneous Current:	NA	0.03% + 5 mV 0.6% + 2 mA <sup>3</sup>
<b>Dynamic Measurement System</b>	Buffer Length: Sampling Rate Range:	NA	4096 points 15.6 $\mu$ s–31200s

<sup>1</sup>The sink current decreases linearly from 2.8A @ 0 V to 1.2 A @ 15 V. The sink current does not track the programmed current.

<sup>2</sup>Following a 30 minute warm-up, the change in output over 8 hours, under constant ambient, load and line operating conditions.

<sup>3</sup>For full scale current changes with a risetime of 20  $\mu$ s, an additional 0.5% error exists in the first data point in the buffer after the change. The error percentage increases proportionally with the decrease in risetime.

Table A-2. Supplemental Characteristics (continued)

Parameter		HP 66111A	HP 66311B
<b>Measurement Time</b> (includes 30 ms <sup>1</sup> data acquisition time and 20 ms data processing overhead)	voltage or current	50 ms average	
<b>Command Processing Time</b> (time for output to begin to change following receipt of digital data)		4 ms average	
<b>Remote Sense Capability</b> (per load lead)		Up to 4 V (add 2 mV to the voltage load regulation specification for each 1 V change in the + output lead due to load current change.)	
<b>Savable Instrument States</b> (applies only in SCPI mode)		4 (in locations 0 to 3)	
<b>RS-232 Interface Capabilities</b>	Baud rates: Data formats: Language:	300 600 1200 2400 4800 9600 7 bits even or odd parity; 8 bits without parity SCPI or COMPatibility <sup>2</sup>	
<b>HP-IB Interface Capabilities</b>	Language: Interface:	SCPI or COMPatibility <sup>2</sup> AH1, C0, DC1, DT1, E1, L4, PPO, RL1, SH1, SR1, T6	
<b>INH/FLT Characteristics</b>	Maximum ratings:  FLT Terminals:  INH Terminals:	16.5 Vdc between terminals 1 and 2; 3 and 4; and from terminals 1 or 2 to chassis ground  Low-level output current = 1.25 mA max. Low-level output voltage = 0.5 V max.  Low-level input voltage = 0.8 V max. High-level input voltage = 2 V min. Low-level input current = 1 mA Pulse width = 100 $\mu$ s min. Time delay = 4 ms typical	
<b>Digital I/O Characteristics</b>	Maximum ratings: Digital OUT Port 0,1,2 (open collector)  Digital IN Port 2: (internal pull-up)	same as INH/FLT Characteristics Output leakage @ 16V = 0.1 mA (ports 0,1) = 12.5 mA (port 2) Output leakage @ 5V = 0.1 mA (ports 0,1) = 0.25 mA (port 2) Low-level output sink current @ 0.5 V = 4 mA Low-level output sink current @ 1 V = 50 mA Low-level input current @ 0.4 V = 1.25 mA High-level input current @ 5 V = 0.25 mA Low-level input voltage = 0.8 V max. High level input voltage = 2.0 V min.	

<sup>1</sup>May be reduced by changing the default conditions of 2048 data points but measurement uncertainty due to noise will increase.<sup>2</sup>COMPatibility language is used to program the HP 663xA Series power supplies. Not all HP 66111A/66311B capabilities are available when using the COMPatibility language.

A - Specifications

**Table A-2. Supplemental Characteristics (continued)**

<b>Parameter</b>		<b>HP 66111A/66311B</b>
<b>Input Ratings:</b> (at full load from 47–63 Hz)	100 Vac mains (87-106 Vac): 115 Vac mains (104-127 Vac): 220 Vac mains (191-233 Vac): 230 Vac mains (207-253 Vac):	1.6 A, 100 W 1.4 A, 100 W 0.8 A, 100 W 0.75A, 100 W
<b>Isolation to Ground</b> (Maximum from either output terminal to chassis)		50 Vdc
<b>Recommended Calibration Interval</b>		1 year from the date the unit is put into service
<b>Regulatory Compliance</b>	Listing pending: Certified to: Conforms to: Complies with:	UL 3111-1 CSA 22.2 No. 1010.1 IEC 1010-1, EN 61010-1 EMC directive 89/336/EEC (ISM Group1 Class B)
<b>Dimensions</b> (see figure 3-1)	Height: Width: Depth:	88.1 mm (3.5in.) 212.8 mm (8.4in.) 444.4 mm (17.5 in.)
<b>Net weight</b>		8.85 kg (19.5 lbs.)
<b>Shipping weight</b>		11.1 kg (24.5 lbs.)



## Verification and Calibration

### Introduction

This appendix includes verification and calibration procedures for the HP 66111A Fast Transient DC Source and the HP 66311B Mobile Communications DC Source. Instructions are given for performing the procedures either from the front panel or from a controller over the HP-IB.

The verification procedures do not check all the operating parameters, but verify that the dc source is performing properly. Performance Tests, which check all the specifications of the dc source, are given in the applicable dc source Service Manual.

---

**IMPORTANT:** Perform the verification procedures before calibrating your dc source. If the dc source passes the verification procedures, the unit is operating within its calibration limits and does not need to be re-calibrated.

---

### Equipment Required

The equipment listed in the following table, or the equivalent to this equipment, is required for verification and calibration.

**Table B-1. Equipment Required**

Equipment	Characteristics	Recommended Model
<b>Digital Voltmeter</b>	Resolution: 10 nV @ 1 V Readout: 8.5 digits Accuracy: >20 ppm	HP 3458A
<b>Current Monitor<sup>1</sup></b>	15 A (0.1 $\Omega$ ), $\pm 0.04\%$ , TC=5ppm/ $^{\circ}$ C	Guildline 9230/15
<b>Load Resistor</b> (3 W min. TC=20ppm/ $^{\circ}$ C)	400 $\Omega$ (verification.) 800 $\Omega$ (calibration)	HP p/n 0811-2878 HP p/n 0811-0600
<b>Power Supply</b>	8 V @ 5 A	HP 6611C or HP 6631B
<b>HP-IB Controller</b>	Full HP-IB capabilities	HP Series 200/300 or equivalent

<sup>1</sup>The 4-terminal current shunt is used to eliminate output current measurement error caused by voltage drops in the load leads and connections. It has special current-monitoring terminals inside the load connection terminals. Connect the voltmeter directly to these current-monitoring terminals.

### Test Setup

Figure B-1 shows the setup for the tests. Be certain to use load leads of sufficient wire gauge to carry the full output current (see chapter 3).

## B - Verification and Calibration

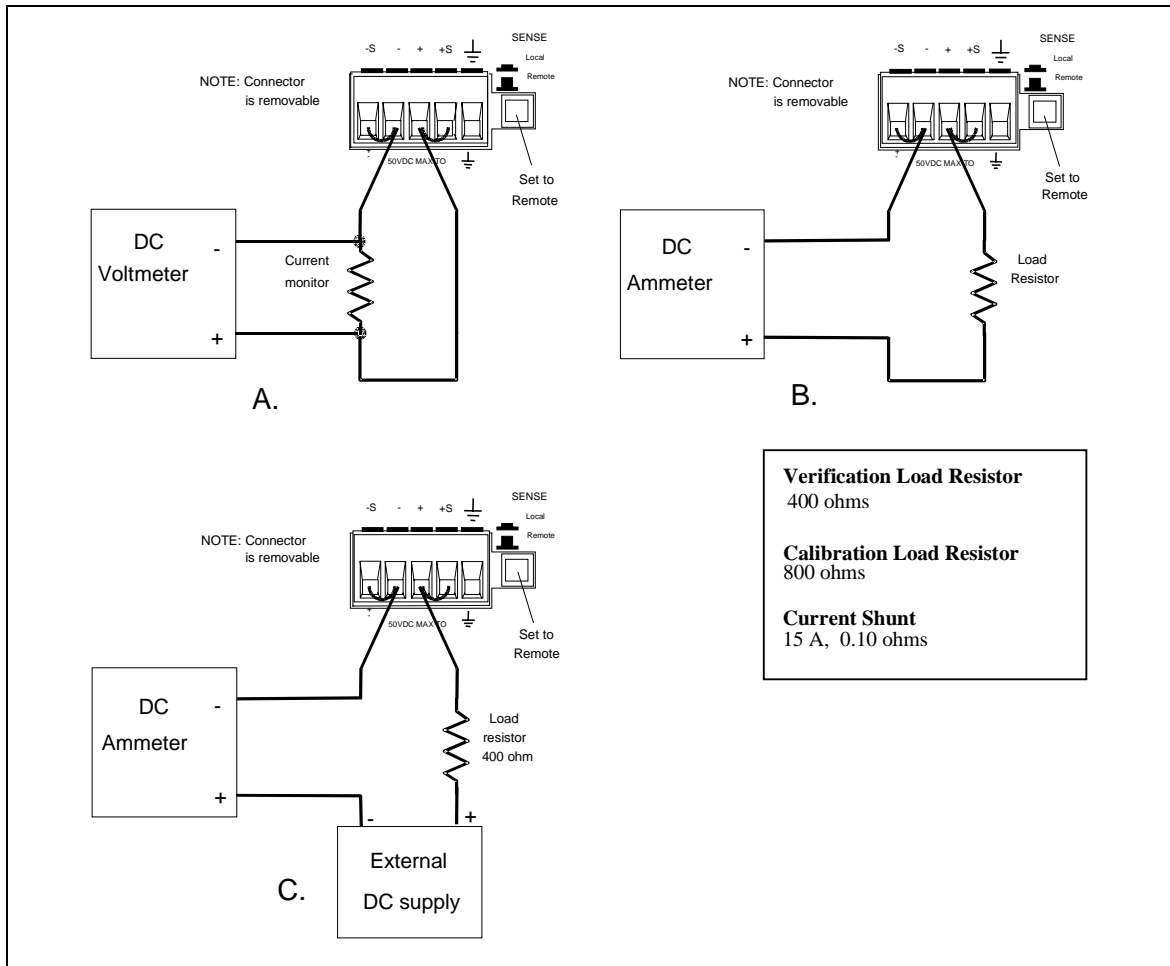

Figure B-1. Verification and Calibration Test Setup

## Performing the Verification Tests

The following procedures assume you understand how to operate the dc source from the front panel as explained in chapter 5. Also, when performing the verification tests from an HP-IB controller, you may have to consider the relatively slow settling times and slew rates of the dc source as compared to computer and system voltmeters. Suitable WAIT statements can be inserted into the test program to give the dc source time to respond to the test commands.

Perform the following tests for operation verification in the order indicated.

1. Turn-On Checkout
2. Voltage Programming and Measurement Accuracy
3. Current Programming and Measurement Accuracy

## Turn-On Checkout

**NOTE:** The dc source must pass turn-on selftest before you can proceed with the verification tests.

Perform the Turn-On Checkout as directed in chapter 4.

## Check the Language Setting

The verification procedures can only be performed with the dc source set to the SCPI programming language.

<b>Action</b>	<b>Normal Result</b>
1. Turn on the dc source, access the Address menu and scroll to the LANG: command.	LANG: SCPI or LANG:COMP
2. If the language is set to COMPatibility, change it to SCPI and press Enter. If the language is already set to SCPI, just continue with the verification procedure.	LANG: SCPI

## Voltage Programming and Measurement Accuracy

This test verifies the voltage programming, HP-IB measurement, and front panel meter functions. Values read back over the HP-IB should be the same as those displayed on the front panel. Measure the dc output voltage at the output terminals. Make sure the sense switch is set to remote and the sense terminals are directly jumpered to the output terminals.

<b>Action</b>	<b>Normal Result</b>
1. Turn off the dc source and connect a DMM to the output terminals.	
2. Turn on the dc source with no load on the output. Set the output voltage to 0.01 V and the output current to 3 A. Press <b>Output On/Off</b> to enable the output.	Output voltage near 0 V. Output current near 0 A.
3. Record the voltage reading on the DMM (Vout) and the voltage reading on the front panel display.	Readings within low voltage limits (see table B-2).
4. Set the output voltage to 15 V.	Output voltage near 15 V.
5. Record the voltage reading on the DMM (Vout) and the voltage reading on the front panel display.	Readings within high voltage limits (see table B-2).

## Current Programming and Measurement Accuracy

This test verifies the current programming and measurement. Connect the appropriate current monitor (see table B-1) as shown in figure B-1A.

### High Range Current Programming and Measurement

<b>Action</b>	<b>Normal Result</b>
1. Turn off the dc source and connect the DMM and current monitor as shown in figure B-1A. Then turn on the dc source.	
2. <b>HP Model 66311B Only</b> Access the Input menu, and set the current sense detector to DC.	CURR:DET DC
3. Set the output voltage to 5 V and the current to 0 A. Press <b>Output On/Off</b> to enable the output.	Output current near 0 A.
4. Divide the voltage drop across the current monitor by its resistance to convert the value to amperes. Record this value (Iout).	Reading within low current limits (see table B-2).
5. Set the output current 3 A.	
6. Divide the voltage drop across the current monitor by its resistance to convert the value to amperes. Record this value (Iout). Also record the current reading on the front panel display.	Readings within high current limits (see table B-2).

## B - Verification and Calibration

### Low Range Current Measurement (HP Model 66311B Only)

Action	Normal Result
7. Turn off and connect the dc source as shown in Figure B-1B using the 400 ohm load resistor. Set the DMM to operate in current mode.	
8. Turn on the dc source, access the Input menu, and set the current range to LOW.	CURR:RANG LOW
9. Set the output voltage to 0 V and the current 3 A. Press <b>Output On/Off</b> to enable the output.	Output current near 0 A.
10. Note the current reading on the DMM (Iout). Record the current reading on the front panel display.	Reading within low current measurement (see table B-2).
11. Set the output voltage to 8 volts.	Output current near +20 mA.
12. Note the current reading on the DMM (Iout). Record the current reading on the front panel display.	Reading within high current measurement (see table B-2).

### Current Sink Measurement

Action	Normal Result
13. Turn off the dc source and connect an external supply to the output of the unit as shown in figure B-1C using the 400 ohm load resistor. Set the DMM to operate in current mode.	
14. Turn on the dc source, access the Input menu, and set the current range to LOW.	CURR:RANG LOW
15. Access the Input menu and set the current sense detector to DC.	CURR:DET DC
16. Turn on the external supply and program it to 8 volts and 5 A. Program the dc source to 0 V and 1 A. Press <b>Output On/Off</b> to enable the output.	Output current near -20 mA.
17. Note the current reading on the DMM (Iout). Record the current reading on the front panel display.	Reading within low current sink measurement (see table B-2).
18. Access the Input menu and set the current range to HIGH.	CURR:RANG HIGH
19. Short out the load resistor by connecting a jumper across it.	Output current approx. -2 A
20. Note the current reading on the DMM (Iout). Record the current reading on the front panel display.	Reading within high current sink measurement (see table B-2).

### Restore the Language Setting

Perform this procedure only if you changed the programming language from COMP to SCPI in the beginning of the verification procedure.

Action	Normal Result
1. Access the Address menu and scroll to the LANG: command.	LANG: SCPI
2. Change the language from SCPI to COMPatibility, and press Enter.	LANG: COMP

Table B-2. Verification Test Record for HP Model 66111A

Model HP 66111A	Report No. _____	Date _____	
Test Description	Minimum Specification	Recorded Results	Maximum Specification
<b>Voltage Programming and Measurement</b>			
Low Voltage $V_{out}$	-10 mV	_____mV	+10 mV
Front Panel measurement	$V_{out}$ -5 mV	_____mV	$V_{out}$ +5 mV
High Voltage $V_{out}$	14.982 V	_____V	15.018 V
Front Panel measurement	$V_{out}$ -9.5 mV	_____V	$V_{out}$ +9.5 mV
<b>Current Programming and Measurement</b>			
Low Current $I_{out}$	-1.33 mA	_____mA	1.33 mA
High Current $I_{out}$	2.9972 A	_____A	3.0028 A
Front Panel measurement	$I_{out}$ -15 mA	_____A	$I_{out}$ +15 mA
<b>Current Sink Measurement</b>			
Low Current Sink measurement	$I_{sink}$ -22.5 $\mu$ A	_____mA	$I_{sink}$ +22.5 $\mu$ A
High Current Sink measurement	$I_{sink}$ -13 mA	_____A	$I_{sink}$ +13 mA

Table B-3. Verification Test Record for HP Model 66311B

Model HP 66311B	Report No. _____	Date _____	
Test Description	Minimum Specification	Recorded Results	Maximum Specification
<b>Voltage Programming and Measurement</b>			
Low Voltage $V_{out}$	-10 mV	_____mV	+10 mV
Front Panel measurement	$V_{out}$ -5 mV	_____mV	$V_{out}$ +5 mV
High Voltage $V_{out}$	14.982 V	_____V	15.018 V
Front Panel measurement	$V_{out}$ -9.5 mV	_____V	$V_{out}$ +9.5 mV
<b>Current Programming and Measurement (High Range)</b>			
Low Current $I_{out}$	-1.33 mA	_____mA	1.33 mA
High Current $I_{out}$	2.9972 A	_____A	3.0028 A
Front Panel measurement	$I_{out}$ -6.5 mA	_____A	$I_{out}$ +6.5 mA
<b>Current Measurement (Low Range)</b>			
Low Current measurement	$I_{out}$ -2.5 $\mu$ A	_____ $\mu$ A	$I_{out}$ +2.5 $\mu$ A
High Current measurement	$I_{out}$ -22.5 $\mu$ A	_____mA	$I_{out}$ +22.5 $\mu$ A
<b>Current Sink Measurement</b>			
Low Current Sink measurement	$I_{sink}$ -22.5 $\mu$ A	_____mA	$I_{sink}$ +22.5 $\mu$ A
High Current Sink measurement	$I_{sink}$ -5.1 mA	_____A	$I_{sink}$ +5.1 mA

## Performing the Calibration Procedure

**NOTE:** The calibration procedure can only be performed from the front panel or using the SCPI language commands.

Table B-1 lists the equipment required for calibration. Figure B-1 shows the test setup.

You do not have to do a complete calibration each time. If appropriate, you may calibrate only the voltage or current and proceed to "Saving the Calibration Constants". However, the voltage or current calibration sequence must be performed in its entirety. The following parameters may be calibrated:

- ◆ voltage programming and measurement
- ◆ overvoltage protection (OVP)
- ◆ current programming and measurement
- ◆ low range measurement
- ◆ ac current measurement

### Front Panel Calibration Menu

The Entry keypad is used for calibration functions.

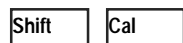

Press this key to access the calibration menu.

**Display**

**Command Function**

CAL ON <value>	Turns calibration mode on when the correct password value is entered.
CAL OFF	Turns calibration mode off
CAL:LEV <char>	Advance to next step in sequence (P1 or P2).
CAL:DATA <value>	Enter an external calibration measurement.
CAL:VOLT	Begin voltage calibration sequence
CAL:VOLT:PROT	Begin voltage protection calibration
CAL:CURR	Begin high range current calibration sequence
CAL:CURR:MEAS:LOW	Begin low range current measurement calibration <sup>1</sup>
CAL:CURR:MEAS:AC	Begin ac current calibration sequence <sup>1</sup>
CAL:SAVE	Saves the calibration constants in non-volatile memory.
CAL:PASS <value>	Set new calibration password.

**Notes:**

<sup>1</sup>HP Model 66311B Only

value = a numeric value

char = a character string parameter

Use and to scroll through the menu commands.

Use and to scroll through the menu parameters.

Use and to select a digit in a numeric entry field.

## Front Panel Calibration Procedure

These procedures assume you understand how to operate front panel keys (see chapter 5). Make sure the sense switch is set to Remote and the sense terminals are directly jumpered to the output terminals. Calibration procedures can only be performed with the dc source set to the SCPI programming language.

### Check the Language Setting

Action	Normal Result
1. Turn on the dc source, access the Address menu and scroll to the LANG: command.	LANG: SCPI or LANG:COMP
2. If the language is set to COMPatibility, change it to SCPI and press Enter. If the language is already set to SCPI, just continue with the calibration procedure.	LANG: SCPI

### Enable Calibration Mode

Action	Display
3. Reset the unit by selecting <b>Output</b> , scrolling to *RST and pressing <b>Enter</b> .	*RST
4. Press <b>Output On/Off</b> to enable the output.	00.003V 0.0006A
5. To begin calibration press <b>Shift Cal</b> , scroll to CAL ON and press <b>Enter</b> .	CAL ON 0.0
6. Enter the calibration password from Entry keypad and press <b>Enter</b> . If the password is correct the <b>Cal</b> annunciator will come on. If CAL DENIED appears, then an internal switch has been set to prevent the calibration from being changed. (See the Service Manual.) If the password is incorrect, an error occurs. If the active password is lost, the calibration function can be recovered by setting an internal switch that defeats password protection. (See the Service Manual.)	CAL DENIED OUT OF RANGE

### Voltage Programming and Measurement Calibration

Action	Display
7. Connect the DMM (in voltage mode) directly to the dc source. Do not connect the load resistor or current shunt.	
8. Press <b>Shift Cal</b> , scroll to CAL VOLT, and press <b>Enter</b> .	CAL:VOLT
9. Press <b>Shift Cal</b> , scroll to CAL LEV, and press <b>Enter</b> to select the first calibration point.	CAL:LEV P1
10. Press <b>Shift Cal</b> , scroll to CAL DATA, press <b>Enter Number</b> , and enter the voltage value displayed on the DMM.	CAL:DATA 0.00
11. Press <b>Shift Cal</b> , scroll to CAL LEV, use ↓ to scroll to P2 (the second calibration point), and press <b>Enter</b> .	CAL:LEV P2
12. Press <b>Shift Cal</b> , scroll to CAL DATA, press <b>Enter Number</b> , and enter the second voltage value displayed on the DMM.	CAL:DATA 0.00

## B - Verification and Calibration

### Overvoltage Protection Calibration

Action	Display
13. Press <b>Shift Cal</b> , scroll to CAL VOLT PROT, and press <b>Enter</b> .	CAL:VOLT:PROT
14. Wait for the dc source to compute the OVP calibration constant. The display returns to Meter mode when the calculation is complete.	

### Current Programming and High-Range Measurement Calibration

Action	Display
15. Connect the appropriate current monitor as shown in figure B-1A. Connect the DMM (in voltage mode) across the current shunt.	
16. Press <b>Shift Cal</b> , scroll to CAL CURR, and press <b>Enter</b> .	CAL:CURR
17. Press <b>Shift Cal</b> , scroll to CAL LEV, and press <b>Enter</b> to select the first calibration point.	CAL:LEV P1
18. Press <b>Shift Cal</b> and scroll to CAL DATA. Wait for the DMM reading to stabilize. Then read the DMM and compute the first current value (DMM reading ÷ shunt resistance). Press <b>Enter Number</b> and enter the first current value in amperes.	CAL:DATA 0.00
19. Press <b>Shift Cal</b> , scroll to CAL LEV, use <b>↓</b> to scroll to P2 (the second calibration point), and press <b>Enter</b> .	CAL:LEV P2
20. Press <b>Shift Cal</b> and scroll to CAL DATA. Wait for the DMM reading to stabilize. Then read the DMM and compute the second current value (DMM reading ÷ shunt resistance). Press <b>Enter Number</b> and enter the second current value in amperes.	CAL:DATA 0.00

### Low-Range Current Measurement Calibration (HP Model 66311B Only)

Action	Display
21. Disconnect all loads from the dc source but leave the sense jumpers in place. Do not connect any equipment to the output until after step #22.	
22. Press <b>Shift Cal</b> , scroll to CAL CURR MEAS LOW, and press <b>Enter</b> .	CAL:CURR:MEAS:LOW
23. Connect the 800 ohm calibration load resistor as shown in figure B-1B. Connect the DMM (in current mode) in series with the load.	
24. Press <b>Shift Cal</b> , scroll to CAL LEV, and press <b>Enter</b> to select the first calibration point.	CAL:LEV P1
25. Press <b>Shift Cal</b> and scroll to CAL DATA. Wait for the DMM reading to stabilize. Press <b>Enter Number</b> and enter the current reading displayed on the DMM in amperes.	CAL:DATA 0.00



**AC Current Measurement Calibration (HP Model 66311B Only)**

<b>Action</b>	<b>Display</b>
26. Disconnect all loads from the dc source but leave the sense jumpers in place.	
27. Hold the calibration switch on the back of the unit in the "ON" position until after the ac calibration completes (in step 29).	
28. Press <b>Shift Cal</b> and scroll to CAL CURR MEAS AC, and press <b>Enter</b> .	CAL:CURR:MEAS AC
29. Wait for the dc source to compute the ac current calibration constant. The display returns to Meter mode when the calculation is complete. Release the calibration switch on the back of the unit.	

**Saving the Calibration Constants**

---

**WARNING:** Storing calibration constants overwrites the existing ones in non-volatile memory. If you are not sure you want to permanently store the new constants, omit this step. The dc source calibration will then remain unchanged.

---

<b>Action</b>	<b>Display</b>
30. Press <b>Shift Cal</b> , scroll to CAL SAVE, and press <b>Enter</b> .	CAL:SAVE
31. Press <b>Shift Cal</b> , select CAL OFF, and press <b>Enter</b> to exit Calibration mode. *RST and *RCL will also set the calibration state to OFF.	CAL OFF
32. If you changed that language setting from Compatibility to SCPI in step #1, change the language setting back to Compatibility.	

**Restore the Language Setting**

---

**NOTE:** Perform this procedure only if you changed the programming language from COMP to SCPI in the beginning of the calibration procedure.

---

<b>Action</b>	<b>Normal Result</b>
33. Access the Address menu and scroll to the LANG: command.	LANG: SCPI
34. Change the language from SCPI to COMPatibility, and press Enter.	LANG: COMP

---

## Calibration Error Messages

Errors that can occur during calibration are shown in the following table.

**Table B-3. HP-IB Calibration Error Messages**

<b>Error</b>	<b>Meaning</b>
401	CAL switch prevents calibration (This is a hardware disable, see the Service Manual.)
402	CAL password is incorrect
403	CAL not enabled
404	Computed readback cal constants are incorrect
405	Computed programming cal constants are incorrect
406	Incorrect sequence of calibration commands

---

## Changing the Calibration Password

The factory default password is 0. You can change the password when the dc source is in calibration mode (which requires you to enter the existing password). Proceed as follows:

<b>Action</b>	<b>Display</b>
1. Begin by pressing <b>Shift Cal</b> and scrolling to the CAL ON command.	CAL ON 0.0
2. Enter the existing password from Entry keypad and press <b>Enter</b>	
3. Press <b>Shift Cal</b> and scroll to the CAL PASS command.	CAL:PASS 0
4. Enter the new password from the keypad. You can use any number with up to six digits and an optional decimal point. If you want the calibration function to operate without requiring any password, change the password to 0 (zero).	

---

**NOTE:** If you want the calibration function to operate without requiring any password, change the password to 0 (zero).

---



---

## Calibration Over the HP-IB

You can calibrate the dc source by using SCPI commands within your controller programming statements. Be sure you are familiar with calibration from the front panel before you calibrate from a controller. Each front panel calibration command has a corresponding SCPI command. When you write your calibration program, perform the calibration procedure in the same order as the front panel procedure documented in this appendix.

The SCPI calibration commands are explained in chapter 8. Calibration error messages that can occur during HP-IB calibration are shown in table B-3.

## Error Messages

### Error Number List

This appendix gives the error numbers and descriptions that are returned by the dc source. Error numbers are returned in two ways:

- ◆ Error numbers are displayed on the front panel
- ◆ Error numbers and messages are read back with the `SYSTEM:ERROR?` query. `SYSTEM:ERROR?` returns the error number into a variable and returns two parameters: an NR1 and a string.

The following table lists the errors that are associated with SCPI syntax errors and interface problems. It also lists the device dependent errors. Information inside the brackets is not part of the standard error message, but is included for clarification.

When errors occur, the Standard Event Status register records them in bit 2, 3, 4, or 5 as described in the following table:

**Table C-1. Error Numbers**

<b>Error Number</b>	<b>Error String [Description/Explanation/Examples]</b>
	<b>Command Errors –100 through –199 (sets Standard Event Status Register bit #5)</b>
–100	Command error [generic]
–101	Invalid character
–102	Syntax error [unrecognized command or data type]
–103	Invalid separator
–104	Data type error [e.g., "numeric or string expected, got block data"]
–105	GET not allowed
–108	Parameter not allowed [too many parameters]
–109	Missing parameter [too few parameters]
–112	Program mnemonic too long [maximum 12 characters]
–113	Undefined header [operation not allowed for this device]
–121	Invalid character in number [includes "9" in octal data, etc.]
–123	Numeric overflow [exponent too large; exponent magnitude >32 k]
–124	Too many digits [number too long; more than 255 digits received]
–128	Numeric data not allowed

**Table C-1. Error Numbers (continued)**

## C – Error Messages

-131	Invalid suffix [unrecognized units, or units not appropriate]
-138	Suffix not allowed
-141	Invalid character data [bad character, or unrecognized]
-144	Character data too long
-148	Character data not allowed
-150	String data error
-151	Invalid string data [e.g., END received before close quote]
-158	String data not allowed
-160	Block data error
-161	Invalid block data [e.g., END received before length satisfied]
-168	Block data not allowed
-170	Expression error
-171	Invalid expression
-178	Expression data not allowed
	<b>Execution Errors –200 through –299 (sets Standard Event Status Register bit #4)</b>
-200	Execution error [generic]
-222	Data out of range [e.g., too large for this device]
-223	Too much data [out of memory; block, string, or expression too long]
-224	Illegal parameter value [device-specific]
-225	Out of memory
-270	Macro error
-272	Macro execution error
-273	Illegal macro label
-276	Macro recursion error
-277	Macro redefinition not allowed
	<b>System Errors –300 through –399 (sets Standard Event Status Register bit #3)</b>
-310	System error [generic]
-350	Too many errors [errors beyond 9 lost due to queue overflow]
	<b>Query Errors –400 through –499 (sets Standard Event Status Register bit #2)</b>
-400	Query error [generic]
-410	Query INTERRUPTED [query followed by DAB or GET before response complete]
-420	Query UNTERMINATED [addressed to talk, incomplete programming message received]
-430	Query DEADLOCKED [too many queries in command string]
-440	Query UNTERMINATED [after indefinite response]

**Table C-1. Error Numbers (continued)**

<b>Selftest Errors 0 through 99 (sets Standard Event Status Register bit #3)</b>	
0	No error
1	Non-volatile RAM RD0 section checksum failed
2	Non-volatile RAM CONFIG section checksum failed
3	Non-volatile RAM CAL section checksum failed
4	Non-volatile RAM STATE section checksum failed
5	Non-volatile RST section checksum failed
10	RAM selftest
11	VDAC/IDAC selftest 1
12	VDAC/IDAC selftest 2
13	VDAC/IDAC selftest 3
14	VDAC/IDAC selftest 4
15	OVDAC selftest
80	Digital I/O selftest error
<b>Device-Dependent Errors 100 through 32767 (sets Standard Event Status Register bit #3)</b>	
213	Ingrd receiver buffer overrun
216	RS-232 receiver framing error
217	RS-232 receiver parity error
218	RS-232 receiver overrun error
220	Front panel uart overrun
221	Front panel uart framing
222	Front panel uart parity
223	Front panel buffer overrun
224	Front panel timeout
401	CAL switch prevents calibration
402	CAL password is incorrect
403	CAL not enabled
404	Computed readback cal constants are incorrect
405	Computed programming cal constants are incorrect
406	Incorrect sequence of calibration commands
407	CV or CC status is incorrect for this command
601	Too many sweep points
602	Command only applies to RS-232 interface
603	CURRENT or VOLTage fetch incompatible with last acquisition
604	Measurement overrange
605	RS-232 port already in use
606	Remote front panel communication error



## Example Programs

---

### Introduction

The example programs in this section are intended to show how some of the same dc source functions can be programmed to each of the following HP-IB interfaces:

1. National Instruments GPIB-PCII Interface/Handler
2. HP BASIC Language System

### Assigning the HP-IB Address in Programs

The dc source address cannot be set remotely. It must be set using the front panel Address key. Once the address is set, you can assign it inside programs. The following example is for HP BASIC and assumes that the HP-IB select code is 7, the address is 6, and the dc source is assigned to the variable PS.

```
1070 ASSIGN @PS TO 706      !HP BASIC Interface
```

For systems using the National Instruments DOS driver, the address is specified in the software configuration program (IBCONFIG.EXE) and assigned a symbolic name. The address then is referenced only by this name within the application program (see the National Instruments GP-IB documentation).

### National Instruments GP-IB Driver

Your program must include the National Instruments header file DECL.BAS. This contains the initialization code for the interface. Prior to running any applications programs, you must set up the interface with the configuration program (IBCONF.EXE).

Your application program will not include the dc source's symbolic name and HP-IB address. These must be specified during configuration (when you run IBCONF.EXE). Note that the primary address range is from 0 to 30. The dc source expects a message termination on EOI or line feed, so set EOI w/last byte of Write. It is also recommended that you set Disable Auto Serial Polling.

All function calls return the status word IBSTA%, which contains a bit (ERR) that is set if the call results in an error. When ERR is set, an appropriate code is placed in variable IBERR%. Be sure to check IBSTA% after every function call. If it is not equal to zero, branch to an error handler that reads IBERR% to extract the specific error.

## D – Example Programs

### Error Handling

If there is no error-handling code in your program, undetected errors can cause unpredictable results. This includes "hanging up" the controller and forcing you to reset the system. National Instruments drivers have routines for detecting program execution errors. Error detection should be used after every call to a subroutine.

### Example 1. National Instruments Interface Example

```
990 '----- Merge DECL.BAS here -----
1000 'DC Source Variable = PS% ; Stand-Alone Address = 706
1005 CODES$=SPACE$(50):MODE$=SPACE$(5):OEVENT$=SPACE$(20)
1010 D$=SPACE$(60):OUTPUT$=SPACE$(40):BDNAME$="PS%"
1015 DIM OUTPUT(2)
1020 '
1025 'Set up dc source interface for DOS driver
1030 CALL IBFIND(BDNAME$,PS%)
1035 IF PS%
1040 CALL IBCLR(PS%)
1045 '
1050 'Program dc source to CV mode with following voltage and current
1055 CODES$ = "VOLTAGE MAX;CURRENT MAX" :GOSUB 2000
1060 '
1065 'Query dc source outputs and print to screen
1070 CODES$ = "MEASURE:VOLTAGE?;CURRENT?" :GOSUB 2000 :GOSUB 3000
1075 VOUT = OUTPUT(1)
1080 IOUT = OUTPUT(2)
1085 PRINT"The programmed levels are "VOUT" Volts and "IOUT" Amps"
1090 '
1095 'Program triggered current level to value insufficient to maintain
1100 'supply within its CV operating characteristic
1105 CODES$ = "CURR:TRIG MIN" :GOSUB 2000
1110 '
1115 'Set operation status mask to detect mode change from CV to CC
1120 CODES$ = "STAT:OPER:ENAB 1024;PTR 1024" :GOSUB 2000
1125 '
1130 'Enable Status Byte OPER summary bit
1135 CODES$ = "*SRE 128" :GOSUB 2000
1140 '
1145 'Arm trigger circuit and send trigger to dc source
1150 CODES$ = "INITIATE:SEQUENCE1;TRIGGER" :GOSUB 2000
1160 'Wait for supply to respond to trigger
1165 FOR I= 1 to 100 :NEXT I
1170 '
1175 'Poll for interrupt caused by change to CC mode and print to screen
1180 SPOL%=0
1185 CALL IBRSP(PS%,SPOL%)
1190 IF (SPOL% AND 128) = 128 THEN POLL = 1 'Set interrupt flag on OPER bit
1195 IF POLL <> 1 THEN GOTO 1230 'No interrupt to service
1200 "CODES$ = "STAT:OPER:EVEN?" :GOSUB 2000 'Query status oper register
1205 CALL IBRD(PS%,OEVENT$) 'Read back event bit
1210 IF IBSTA%
1215 OEVENT=VAL(OEVENT$)
1220 IF (OEVENT AND 1024) = 1024 THEN PRINT "Supply switched to CC mode."
```



```

1225 '
1230 'Clear status circuit
1235 CODES$="*CLS" :GOSUB 2000
1240 FOR I=1 TO 50 :NEXT I 'Wait for supply to clear
1245 '
1250 'Disable output and save present state to location 2
1255 CODES$ = "OUTPUT OFF;*SAV 2" :GOSUB 2000
1260 END
1265 '
2000 'Send command to dc source
2005 CALL IBWRT(PS%,CODES$)
2010 IF IBSTAT%
2015 RETURN
1250 'Disable output and save present state to location 2
1255 CODES$ = "OUTPUT OFF;*SAV 2" :GOSUB 2000
1260 END
1265 '
2000 'Send command to dc source
2005 CALL IBWRT(PS%,CODES$)
2010 IF IBSTAT%
2015 RETURN
2020 '
2100 'Error detection routine
2105 PRINT "GPIO error. IBSTAT% = HEX$(IBSTAT%)
2110 PRINT " IBERR% = ";IBERR%" in line ";ERL
2115 STOP
2120 '
3000 'Get data from dc source
3005 CALL IBRD(PS%,OUTPUT$)
3010 IF IBSTA%
3015 I=1 'Parse data string
3020 X=1
3025 C=INSTR(I,OUTPUT$,";")
3030 WHILE C <> 0
3035 D$=MID$(OUTPUT$,I,C-I)
3040 OUTPUT(X)=VAL(D$) 'Get values
3045 I=C+1
3050 C=INSTR(I,OUTPUT$,";")
3055 X=X+1
3060 WEND
3065 D$=RIGHT$(OUTPUT$,LEN(OUTPUT$)-(I-1))
3070 OUTPUT(X)=VAL(D$)
3075 OUTPUT$=SPACE$(40) 'Clear string
3080 RETURN

```

## D – Example Programs

### HP BASIC

The HP BASIC for controllers and HP BASIC for Windows both provide access to HP-IB functions at the operating system level. This makes it unnecessary to have the header files required in front of DOS applications programs. Also, you do not have to be concerned about controller "hangups" as long as your program includes a timeout statement. Because the dc source can be programmed to generate SRQ on errors, your program can use an SRQ service routine for decoding detected errors. The detectable errors are listed in Appendix C.

#### Example 2. Controller Using HP BASIC

```
1000 !Dc source at stand-alone address = 706
1005 OPTION BASE 1
1010 DIM Codes$(80),Response$(80),Mode$(32)
1015 !
1020 !Program dc source to CV mode with following voltage and current
1025 OUTPUT 706;"VOLTAGE MAX;CURRENT MAX"
1030 !
1035 !Query dc source outputs and print to screen
1040 OUTPUT 706;"MEASURE:VOLTAGE?;CURRENT?"           !Query output levels
1045 ENTER 706;Vout,Iout
1050 PRINT "The output levels are ";Vout;" Volts and ";Iout" Amps"
1055 !
1060 !Program current triggered level to a value insufficient to maintain
1065 !supply within its CV operating characteristic
1070 OUTPUT 706;"CURR:TRIG MIN"
1075 !
1080 !Set operation status mask to detect mode change from CV to CC
1085 OUTPUT 706;"STAT:OPER:ENAB 1024;PTR 1024"
1090 !
1095 !Enable Status Byte OPER summary bit
1100 OUTPUT 706;"*SRE 128"
1105 !
1110 !Arm trigger circuit and send trigger to dc source
1115 OUTPUT 706;"INITIATE:SEQUENCE1;TRIGGER"
1130 !Poll for interrupt caused by change to CC mode and print to screen
1135 Response=SPOLL(706)
1140 IF NOT BIT (Response,7) THEN GOTO 1130           !No OPER event to report
1145 OUTPUT 706;"STAT:OPER:EVEN?"                   !Query status operation register
1150 ENTER 706;Oevent                               !Read back event bit
1155 IF BIT(Oevent,10) THEN PRINT "Supply switched to CC mode."
1160 !
1165 !Clear status
1170 OUTPUT 706;"*CLS"
1175 !
1180 !Disable output and save present state in location 2
1185 OUTPUT 706;"OUTPUT OFF;*SAV 2"
1190 END
```

## Pulse Measurements

The following programs illustrate how to make a pulse measurement over the HP-IB. The measurement function is set to ACDC, which gives the best results for current waveforms that have ac content. The measurement incorporates 100 readings taken at time intervals of 20 microseconds, for a total measurement time of 2 milliseconds. The trigger point for the pulse measurement occurs at 0.1 amperes on the positive slope of the current pulse. The measurement offset is programmed so that 20 measurement points prior to the trigger are also returned as part of the measurement sample.

Because measurement triggers are initiated by the output pulse, a FETCh command is used to return the measurement data. FETCh commands are also used to return the MAXimum, MINimum, HIGH, and LOW values of the measurement. MEASure commands cannot be used to return data in this example because they always acquire *NEW* measurement data each time they are used.

To produce the output pulses in this example, an electronic load must be connected and programmed to generate 3-ampere pulses with a duty cycle of 100 microseconds at 1000 Hz. The dc source address is 705, and the load address is 706. If required, change these parameters in the appropriate statements.

### Example 3. Current Pulse Measurement Using HP BASIC

```

10    !Rev A.00.00
20    OPTION BASE 1
30    DIM Curr_array(100)
40    !
50    ASSIGN @Ps TO 705
60    ASSIGN @Ld TO 706
80    OUTPUT @Ps;"*RST"                ! Sets supply to default values
90    OUTPUT @Ps;"OUTP ON"            ! Turn on power supply output
100   OUTPUT @Ps;"VOLT 5"             ! Program power supply to 5 volts
110   !
120   OUTPUT @Ld;"CURR:LEVEL 0"       ! Set up electronic load to produce
pulses
130   OUTPUT @Ld;"CURR:TLEVEL 3"
140   !
150   OUTPUT @Ld;"TRAN:FREQ 1000"
160   OUTPUT @Ld;"TRAN:DCYCLE 10"
170   OUTPUT @Ld;"TRAN:MODE CONT"
180   OUTPUT @Ld;"TRAN:STATE ON"
190   !
200   OUTPUT @Ps;"SENS:CURR:DET ACDC" ! Set meter to ACDC
210   OUTPUT @Ps;"SENS:CURR:RANG MAX" ! High Current range
220   OUTPUT @Ps;"TRIG:ACQ:SOUR INT"  ! Set to trigger on pulse
230   OUTPUT @Ps;"SENS:FUNC ""CURR""  ! Acquire current reading
240   OUTPUT @Ps;"TRIG:ACQ:LEV:CURR .1" ! Trigger at 0.1 amps
250   OUTPUT @Ps;"TRIG:ACQ:SLOPE:CURR POS" ! Trigger on positive slope
260   OUTPUT @Ps;"TRIG:ACQ:HYST:CURR .05" ! Set hysteresis of trigger
270   OUTPUT @Ps;"SENS:SWE:TINT 20E-6" ! Set sample time interval to 20us
280   OUTPUT @Ps;"SENS:SWE:POIN 100"  ! Set number of measurement samples
in sweep
290   OUTPUT 705;"SENS:SWE:OFFS:POIN -20" ! Number of sample points before
trigger
300   OUTPUT @Ps;"INIT:NAME ACQ"      ! Initiate the trigger system.
310   !                                Controller now waits for trigger
to occur.
320   OUTPUT @Ps;"FETCH:ARRAY:CURR?"  ! Get the data after measurement
completes.

```

## D – Example Programs

```
330    !
340    ENTER @Ps;Curr_array(*)           ! Enters all 100 data points
350    PRINT Curr_array(*)              ! Print all data points
360    !
370    OUTPUT @Ps;"FETCH:CURR:MAX?"     ! Get more data from previous
measurement.
380    ENTER @Ps;Curr_max
390    PRINT "MAX CURRENT",Curr_max
400    !
410    OUTPUT @Ps;"FETCH:CURR:MIN?"
420    ENTER @Ps;Curr_min
430    PRINT "MIN CURRENT",Curr_min
440    !
450    OUTPUT @Ps;"FETCH:CURR:HIG?"
460    ENTER @Ps;Curr_hi
470    PRINT "HIGH CURRENT",Curr_hi
480    !
490    OUTPUT @Ps;"FETCH:CURR:LOW?"
500    ENTER @Ps;Curr_low
510    PRINT "LOW CURRENT",Curr_low
520    !
530    END
```

When this program runs, it returns 100 measurement data points as well as the MIN, MAX, HIGH, and LOW data in the following format:

```
.030585    .031869    .0344369   .031655    .0320829   .0325109   .0333669   .0340089
.0320825   .031449    .031227    .031441    .0337949   .0327249   .031869    .031655
.0327249   .031013    .0325109   .0333669   3.09751    3.1814     3.14266    3.13667
3.13817    3.13624    .977283    .0667496   .0245932   .0280171   .031013    .031655
.0331529   .0350788   .0348648   .0327249   .031227    .0327249   .031227    .030799
.031869    .0329389   .030371    .031655    .031869    .0329389   .031869    .0322869
.0320829   .0325109   .0333669   .0340089   .0348648   .0327249   .031227    .0327249
.0320829   .030371    .031449    .031227    .031441    .0337949   .031449    .0333669
.031441    .0337949   .030371    .031655    .031869    .0329389   .031869    .0293011
.031441    .0337949   .0327249   .031869    .031655    .031655    .0320829   .031227
.0322969   .031655    .0327249   .0340089   2.97661    3.18632    3.14523    3.13496
3.13453    3.13731    1.32438    .0836549   .0258772   .0284451   .0275891   .0329389
.0329389   .0333669   .0322969   .0333669
MAX CURRENT      3.18632
MIN CURRENT      .0245932
HIGH CURRENT     3.1371
LOW CURRENT      .0314077
```

### Example 4. Voltage Pulse Measurement Using VISA Library Calls

```
#include <visa.h>
#include <stdio.h> /* for printf */
#include <stdlib.h>

ViStatus main(void)
{
    ViSession defRM, instrumentHandle;
    ViStatus err;
    ViReal64 measvoltage, meascurrent;
    ViReal64 resultDC, resultRMS, resultMIN, resultMAX, resultHIGH, resultLOW;
    ViReal64 voltArray[10];
    ViInt32 i, numReadings ;
```

```

/* initialize the VISA session */
err = viOpenDefaultRM(&defRM);
if (err)
{
    printf("viOpenDefaultRM error, check your hardware connections\n");
    exit (-1);
}

/* Open the instrument at address 5 for Communication */
err = viOpen(defRM, "GPIB0::5::INSTR", VI_NULL, 5000, &instrumentHandle);
if (err)
{
    viClose(defRM);
    printf("viOpen error, check the device at address 5\n");
    exit (-1);
}

/* Reset the instrument */
viPrintf(instrumentHandle, "*RST\n");

/* turn on the output */
viPrintf(instrumentHandle, "OUTP 1\n");

/* Set output voltage (2V) and current (1A) levels, turn output on*/
viPrintf(instrumentHandle, "VOLT %.5lg;CURR %.5lg\n", 2.0, 1.0);

/* Measure the dc voltage level at the output terminals */
viQueryf(instrumentHandle, "MEAS:VOLT?\n", "%lf", &measvoltage);

/* Measure the dc current level at the output terminals */
viQueryf(instrumentHandle, "MEAS:CURR?\n", "%lf", &meascurrent);

printf ("Output Voltage = %f; Output Current = %f \n",
        measvoltage,meascurrent);

/* configure dc source for dynamic measurements */
/* change sweep parameters */
viPrintf(instrumentHandle, "SENS:SWE:TINT %.5lg;POIN %ld;OFFS:POIN %ld\n",
        31.2E-6, /* sampling rate = 31.2us */
        256, /* sweep size = 256 points */
        -4); /* pre-trigger offset = 4 points (~125us) */

/* setup the voltage sensing triggered measurement parameters */
/* voltage trigger level to 2.75V */
/* hysteresis band to +/- 0.1V */
/* positive slope */
/* trigger count */
/* acquisition triggered by measurement */
viPrintf(instrumentHandle, "SENS:FUNC \"VOLT\"\n");
viPrintf(instrumentHandle, "TRIG:ACQ:LEV:VOLT %.5lg\n", 2.75);
viPrintf(instrumentHandle, "TRIG:ACQ:HYST:VOLT %.5lg\n", 0.1);
viPrintf(instrumentHandle, "TRIG:ACQ:SLOP:VOLT POS\n");
viPrintf(instrumentHandle, "TRIG:ACQ:COUN:VOLT %ld\n", 1);
viPrintf(instrumentHandle, "TRIG:ACQ:SOUR INT\n");

/* initiate the acquisition system for measurement trigger */
printf ("Arm acquisition system...\n");
viPrintf(instrumentHandle, "INIT:NAME ACQ\n");

/* must allow time for pre-triggered samples */
printf ("Pre-trigger delay...\n");

```

## D – Example Programs

```
/* trigger the acquisition by changing the output voltage level to 5V */
printf ("Trigger acquisition...\n");
viPrintf(instrumentHandle, "VOLT %.5lg\n", 5.0);

/* fetch dynamic measurements from the same measurement data */
viQueryf(instrumentHandle, "FETC:VOLT?\n", "%lf", &resultDC);
viQueryf(instrumentHandle, "FETC:VOLT:ACDC?\n", "%lf", &resultRMS);
viQueryf(instrumentHandle, "FETC:VOLT:MAX?\n", "%lf", &resultMAX);
viQueryf(instrumentHandle, "FETC:VOLT:MIN?\n", "%lf", &resultMIN);
viQueryf(instrumentHandle, "FETC:VOLT:HIG?\n", "%lf", &resultHIGH);
viQueryf(instrumentHandle, "FETC:VOLT:LOW?\n", "%lf", &resultLOW);

/* display measurement results */
printf("Dynamic voltage measurements:\n");
printf("dc=%f V\n rms=%f V\n max=%f V\n min=%f V\n high=%f V\n low=%f
V\n",
    resultDC, resultRMS, resultMAX, resultMIN, resultHIGH, resultLOW);

/* fetch first 10 data points from the measurement */
numReadings = 10;
viQueryf(instrumentHandle, "FETC:ARR:VOLT?\n", "%,#lf%*t", &numReadings,
&voltArray[0]);
for (i=0; i<numReadings; i++)
    printf(" Array Data[%d] = %f V\n", i, voltArray[i]);

/* reset sweep parameters for faster measurement */
viPrintf(instrumentHandle, "SENS:SWE:TINT %.5lg;POIN %ld;OFFS:POIN %ld\n",
    15.6E-6, /* sampling rate */
    2048, /* sweep size */
    0); /* pre-trigger points */

/* Measure final dc voltage level at the output terminals */
viQueryf(instrumentHandle, "MEAS:VOLT?\n", "%lf", &measvoltage);

printf (" Output Voltage = %f V\n", measvoltage);

/* close all opened sessions */
viClose(instrumentHandle);
viClose(defRM);

printf ( "PROGRAM COMPLETED \n");

printf("Press Enter key to continue...\n");
getchar();

return VI_SUCCESS ;
}
```

When this program runs, it returns the DC, RMS, MIN, MAX, HIGH, and LOW data in 10 measurement data points in the following format:

```
Output Voltage = 1.999860; Output Current = -0.000043
Arm acquisition system...
Pre-trigger delay...
Trigger acquisition...
Dynamic voltage measurements:
  dc = 5.002660 V
  rms = 5.002660 V
  max = 5.080140 V
  min = 1.996970 V
  high= 5.002310 V
  low = 3.538550 V
Array Data[0] = 2.000360 V
Array Data[1] = 1.999680 V
Array Data[2] = 1.998320 V
Array Data[3] = 1.996970 V
Array Data[4] = 3.214240 V
Array Data[5] = 4.064840 V
Array Data[6] = 4.538600 V
Array Data[7] = 4.923570 V
Array Data[8] = 4.941870 V
Array Data[9] = 5.025240 V
Output Voltage = 5.002450 V
PROGRAM COMPLETED
Press Enter key to continue...
```

## DFI Programming Example

The following program illustrates how to program the DFI port so that it goes low when an OCP condition turns off the output of the unit. To clear an overcurrent condition, the cause of the condition must first be removed and then an OUTPUT:PROTECTION:CLEAR command must be sent. Note that the status event register will not clear the DFI port until the register is read.

### Example 5. DFI Example Using HP BASIC

```
10 !Rev A.00.00
20 ASSIGN @Ps TO 705
30 OUTPUT @Ps;"*RST"           ! Sets supply to default values
40 OUTPUT @Ps;"OUTP ON"       ! Turn on power supply output
50 OUTPUT @Ps;"VOLT 10;CURR .1" ! Program power supply voltage and current
60 !
70 OUTPUT @Ld;"CURR:PROT:STAT ON" ! Turn on overcurrent protection
80 OUTPUT @Ld;"OUTP:DFI:STAT ON" ! Turn on DFI port
90 OUTPUT @Ld;"OUTP:DFI:SOUR QUES" ! Select DFI bit from Questionable status
register
100 OUTPUT @Ld;"STAT:QUES:ENAB 2;PTR 2"! Unmask bit 2 (OCP) on positive
transition
110 !
120 OUTPUT @Ld;"OUTP:PROT:CLE" ! Clears the protection circuit
130 OUTPUT @Ld;"STAT:QUES:EVENT?" ! Clears the Event register and DFI
140 OUTPUT @Ld;EVENT          ! Reads the event and clears the buffer
190 !
```





## Line Voltage Conversion

---

**WARNING:** *Shock Hazard.* Operating personnel must not remove instrument covers. Component replacement and internal adjustments must be made only by qualified service personnel.

---

### Open the Unit

- ◆ Turn off ac power and disconnect the power cord from the unit.
- ◆ Loosen the two screws on the rear bezel and remove the bezel (use a #15 Torx drive).
- ◆ Remove the two screws on the bottom of the unit (use a #15 Torx drive).
- ◆ Pull the cover back to remove it from the unit.

### Configure the Power Transformer

- ◆ Locate the ac input wiring harness on the left side of the transformer
- ◆ Use a needle nose pliers and connect the ac input wiring harness according to the information in the following figure:

## E – Line Voltage Conversion

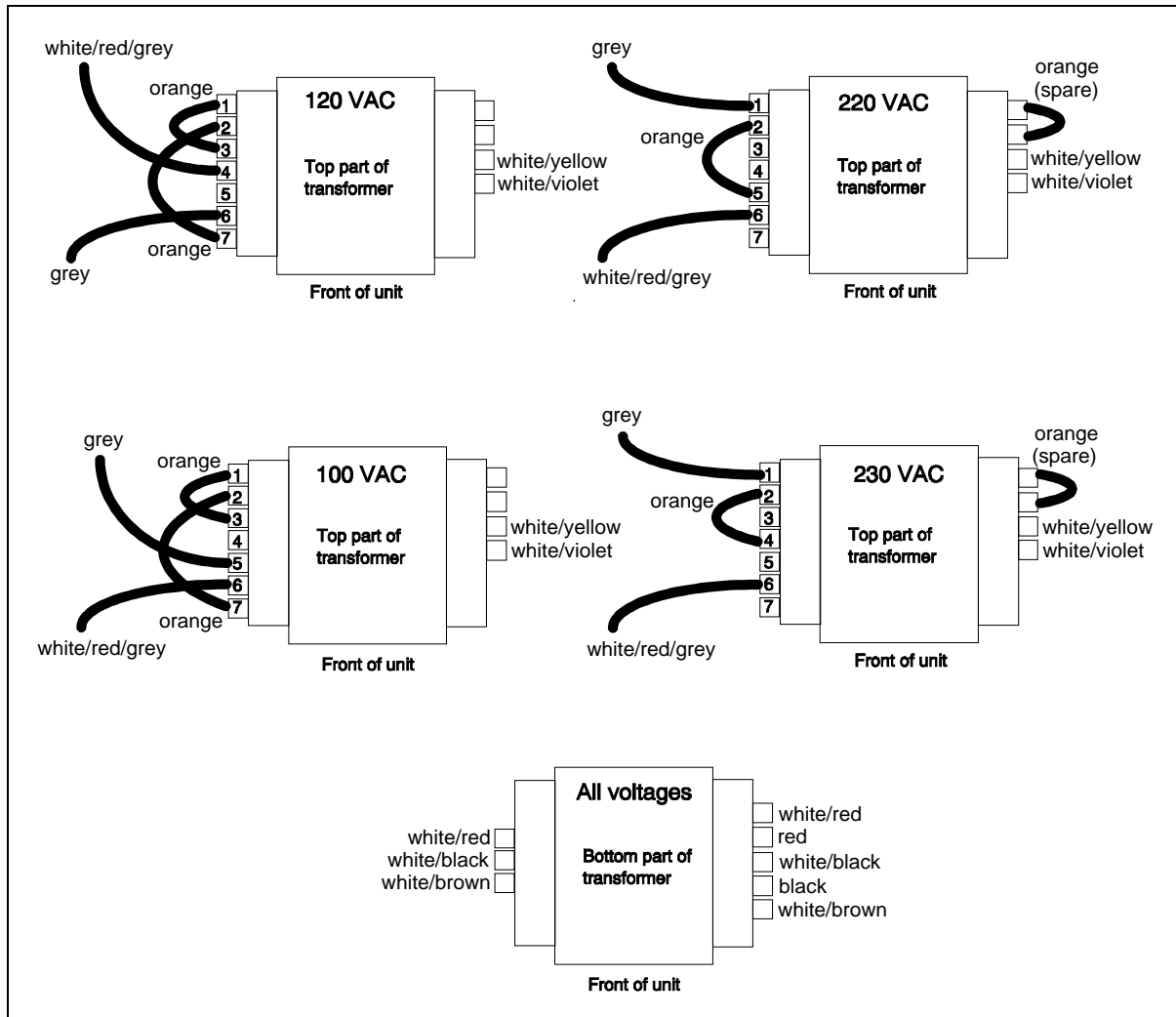

Figure E-1, Power Transformer AC Input Connections

### Install the Correct Line Fuse

- ◆ Unscrew the line fuse cap from the rear panel and install the correct fuse.  
**For 100/120 Vac operation:** 2 A slow-blow; HP part number 2110-0303  
**For 220/230 Vac operation:** 1 A slow-blow; HP part number 2110-0007
- ◆ Mark the voltage setting that the unit has been set to on the rear panel label.

### Close the Unit

- ◆ Replace the outer cover.
- ◆ Reconnect the power cord and turn on the unit.

# Compatibility Language

---

## Introduction

The HP 66311B dc source covered by this manual is programmatically compatible with the HP 6632A, 6633A, and 6634A dc power supplies. This means that by using COMPatibility language mode you can program the HP 66311B over the HP-IB using COMPatibility commands.

To switch from SCPI commands to COMPatibility commands (and vice versa), use the SYST:LANG command, as documented in chapter 8. The language setting is saved in non-volatile memory.

Table F-2 summarizes the COMPatibility commands. You may need to refer to the HP Series 6632A, 6633A, and 6634A Operating Guide (HP p/n 5957-6360) for complete information on the COMPatibility commands.

The rest of this appendix discusses the COMPatibility language status system, and the COMPatibility language error codes.

---

**NOTE:** For complete information on the Compatibility programming language, order the HP 6632A/6633A/6634A Operating manual, HP p/n 5957-6360.

---

**Table F-1. COMPatibility Power-on Settings**

<b>Command</b>	<b>Setting</b>	<b>Command</b>	<b>Setting</b>
DC	1 (ON)	POL	1 (normal)
DLY	8 ms (fast) 80 ms (normal)	PON	last stored value
DSP	1 (ON)	RELAY	1 (close)
ISET	0.04 A (66311B) 0.02 A (6632B) 0.008 A (6633B) 0.004 A (6634B)	RLYPON	1 (close)
OCP	OFF	SRQ	0
OUT	1 (ON)	UNMASK	0
OVSET	MAX	VSET	0 V

**Table F-2. COMPatibility Commands**

<b>Compatibility Command</b>	<b>Description</b>	<b>Similar SCPI Command</b>
ASTS?	This command reads the contents of the accumulated status register, which stores any bit condition entered in the status register since the accumulated status register was last read, regardless of whether the condition still exists. Data Representation: ZZZZD	STAT:OPER? STAT:QUES? *ESE?
CLR	This command initializes the dc source to the power-on state. It also resets the PON bit in the serial poll register. The command performs the same function as the Device Clear (DCL) interface message.	*RST
DC 0   1	Only applies to units with Relay Option 760. This command enables or disables the output without affecting the state of the output relays. Initial condition: DC 1	OUTP:STAT[:NOR ] 0   1   OFF   ON
DLY <n>	This command programs the delay time between the programming of an output change that produces a CV, CC, or an UNREG condition, and the recording of that condition by the status registers. This can be used to prevent false triggering of the OverCurrent Protection feature (OCP). Initial delay: 0.08s (Normal); 0.008s (Fast).	OUTP:PROT:DEL
DSP 0   1	This command enables or disables the dc source's front panel display. Initial condition: DSP 1	DISP 0 1 OFF ON
ERR?	This command determines the type of programming error detected by the dc source. A remote programming error sets the ERR bit in the status register, which can be enabled by UNMASK to request service.	SYST:ERR?
FAULT?	This command reads which bits have been set in the fault register. A bit is set in the fault register when the corresponding bit in the status register changes from inactive to active AND the corresponding bit in the mask register has been enabled. The fault register is reset only after it has been read. The decimal equivalent of the total bit weight of all enabled bits is returned. Data Representation: ZZZZD	STAT:OPER? STAT:QUES? *ESE
ID?	This command causes the dc source to report its model number and any options that affect the dc source's output. Data Representation: HP663XA	*IDN?
IOUT?	This command measures and returns the actual output current. Data Representation: SD.DDDD	MEAS:CURR?
ISET <n>	This command programs the output current. See Table 8-3 for the programming range of this command. Initial condition: Table F-1	CURR
OCP 0   1	This command enables or disables the dc source's overcurrent protection. If this function is enabled and the dc source goes into CC mode, the output of the dc source is disabled. Initial condition: OCP 0	CURR:PROT:STAT 0   1   OFF   ON
OUT 0   1	This command enables or disables the dc source's output. The dc source will be able to implement commands even while the output is disabled. Initial condition: OUT 1	OUTP:STAT 0   1   OFF   ON

Table F-2. COMPatibility Commands (continued)

Compatibility Command	Description	Similar SCPI Command
OVSET <n>	This command programs the overvoltage protection. See Table 8-3 for the programming range of this command. Initial condition: MAX	VOLT:PROT
POL 0   1	Only applies to units with Option 760. This command sets the polarity of the output relays to either normal (1) or inverted (0). Initial condition: POL 1	OUTP:REL:POL 0 1
PON 0   1	This command enables (1) or disables (0) SRQ at power-on. Initial condition: last programmed value	PSC 0   1
RELAY 0   1	Only applies to units with Relay Option 760. This command opens (0) or closes (1) the output relays without affecting the programmed output state of the unit. Initial condition: RELAY 1	OUTP:REL 0   1
RLYPON 0   1	Only applies to units with Relay Option 760. This command opens (0) or closes (1) the output relays at power-on without affecting the programmed output state of the unit. Initial condition: RLYPON 1	RCL 0
ROM?	This command returns the ROM version of the dc source. Data Representation: AAA AAA	*IDN?
RST	This command resets the dc source if the output is disabled by the output protection circuits.	OUTP:PROT:CLE
SENS:CURRE:RANG <n>	This command sets the current measurement range of the dc source. See Table 8-3 for the programming range. Initial condition: MAX	SENS:CURRE:RANG
SENS:PROT:STAT 0   1	This command enables/disables the open sense detect feature. Initial condition: 1	SENS:PROT:STAT
SENS:SWE:POIN <n>	This command defines the number of data points in a measurement sweep. Initial condition: 32	SENS:SWE:POIN
SENS:SWE:TINT <n>	This command defines the time period between measurement samples. Initial condition: 15.6 s.	SENS:SWE:TINT
SRQ 0   1	These commands enable or disable the dc source's ability to request service from the controller for fault conditions. UNMASK defines which conditions are defined as faults. Initial condition: SRQ 0	*SRE
STS?	This command reads the contents of the status register, which maintains the present status of the dc source. Data Representation: ZZZZD	STAT:OPER:COND? STAT:QUES:COND? *ESE?
SYST:LANG	This command causes the alternate language to become active and to be stored in nonvolatile memory. In this case, the commands are equivalent. After being shut off, the dc source will resume in the last-selected language when power is restored. The parameter must be either COMP or SCPI.	SYST:LANG

F – Compatibility Language

**Table F-2. COMPatibility Commands (continued)**

Compatibility Command	Description	Similar SCPI Command
TEST?	This command causes the dc source to run selftest and report any detected failures. Data Representation: ZZZZD	*TST?
UNMASK xxx	These commands determine the conditions that will set bits in the fault register, allowing the operator to define the conditions that will be reported as fault. Fault conditions can be enabled by sending the decimal equivalent of the total bit weight of all conditions to be enabled.	STAT:OPER:ENAB STAT:QUES:ENAB *ESE
VOUT?	This command measures and returns the actual output voltage. Data Representation: SZZD.DD; (SZD.DDD for 6634B only)	MEAS:VOLT?
VSET <n>	This command programs the output voltage. See Table 8-3 for the programming range of this command. Initial condition: 0 V	VOLT

A = Alpha

D = Digit

S = Sign (blank for positive and – for negative)

Z = Digit with leading zeros output as spaces

**Table F-3. COMPatibility Errors**

Error	NumberError String [Description/Explanation/Examples]
ERR 0	No error
ERR 1	EEPROM save failed [Data write to non-volatile memory failed]
ERR 2	Second PON after power-on [More than one PON command received after power-on. Only one is allowed.]
ERR 4	RLYPON sent with no relay option present [A RLYPON command was sent with no relay option present.]
ERR 5	No relay option present [A relay option command was sent with no relay option present.]
ERR 8	Addressed to talk and nothing to say [The unit was addressed to talk without first receiving a query.]
ERR 10	Header expected [A non-alpha character was received when a header was expected.]
ERR 11	Unrecognized header [The string of alpha characters received was not a valid command.]
ERR 20	Number expected [A non-numeric character was received when a number was expected.]
ERR 21	Number Syntax [The numeric character received did not represent a proper number.]
ERR 22	Number out of internal range [The number received was too large or small to be represented in internal format.]
ERR 30	Comma [A comma was not received where one was expected.]
ERR 31	Terminator expected [A valid terminator was not received where one was expected.]
ERR 41	Parameter Out [The number received exceeded the limits for its associated command.]
ERR 42	Voltage Programming Error [The programmed value exceeded the valid voltage limits.]
ERR 43	Current Programming Error [The programmed value exceeded the valid current limits.]
ERR 44	Overvoltage Programming Error [The programmed value exceeded the valid overvoltage limits.]
ERR 45	Delay Programming Error [The programmed value exceeded the valid delay limits.]
ERR 46	Mask Programming Error [The programmed value exceeded the fault mask limits.]
ERR 51	EEPROM Checksum [EEPROM failed, or a new uncalibrated EEPROM was installed.]

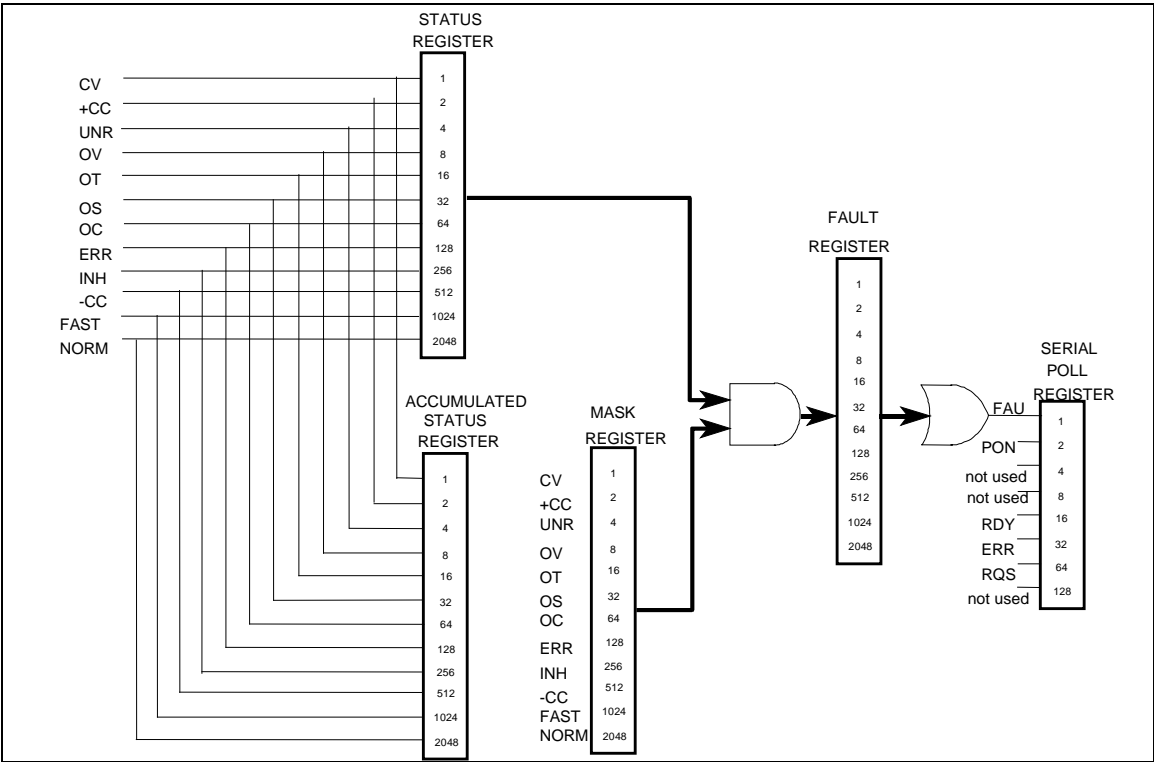

Figure F-1. COMpatibility Status Model

Table F-4. Bit Assignment of Status, Astatus, Fault, & Mask Registers

Bit Position	11	10	9	8	7	6	5	4	3	2	1	0
Bit Name	NORM	FAST	-CC	INH	ERR	OC	OS	OT	OV	UNR	+CC	CV
Bit Weight	2048	1024	512	256	128	64	32	16	8	4	2	1

CV = The unit is operating in constant voltage mode.  
 +CC = The unit is operating in constant current mode.  
 UNR = The output of the unit is unregulated.  
 OV = The overvoltage protection circuit has tripped.  
 OT = The over-temperature protection circuit has tripped.  
 OC = The overcurrent protection circuit has tripped.  
 OS = Open sense lead detected  
 ERR = A programming error has occurred. Use ERR? to clear.  
 -CC = The unit is operating in negative constant current mode.  
 INH = The external remote inhibit signal has turned the output off.  
 FAST = The output is in Fast operating mode. (HP 6632B, 6633B, 6634B only)  
 NORM = The output is in Normal operating mode. (HP 6632B, 6633B, 6634B only)

Table F-5. Bit Configuration of Serial Poll Register

Bit Position	7	6	5	4	3	2	1	0
Bit Name	not used	RQS	ERR	RDY	not used	not used	PON	FAU
Bit Weight		64	32	16			2	1

RQS = The dc source has generated a service request. Use a serial poll to clear.  
 ERR = Same as ERR bit in Status register. Use ERR? to clear.  
 RDY = This bit cleared when unit busy processing commands. Set when processing complete.  
 PON = A Power-on has occurred. Use CLR to clear.  
 FAU = A bit has been set in the Fault register. Use FAULT? to clear.





# Index

- -- -- --, 47, 52  
- sense open, 32
- +—
- + sense open, 32  
+/- sense open, 32  
+/- terminals, 28  
+S/-S terminals, 28
- 0—
- 0 ... 9, 49
- A—
- AARD, 63  
ABORT, 117  
ac line conversion, 161  
accessories, 20  
**ACDC**, 102  
ACDC current detector, 53  
airflow, 27  
annunciators  
  Addr, 44  
  Cal, 44  
  CC, 44  
  CV, 44  
  Dis, 44  
  Err, 44  
  OCP, 44  
  Prot, 44  
  Rmt, 44  
  Shift, 44  
  SRQ, 44  
  Unr, 44  
average measurements, 73  
AWG ratings, 28
- B—
- bus, 123
- C—
- cables, 20  
calibration, 142  
  current programming - high range, 144  
  current programming - low range, 144  
  enable, 143  
  equipment, 137  
  error messages, 146  
  menu, 142  
  OVP, 144  
  password, 146  
  peak current, 145  
  saving, 145  
  setup, 137  
  voltage measurement, 143  
  voltage programming, 143  
calibration commands, 92  
  CAL CURR, 92  
  CAL CURR MEAS AC, 92  
  CAL CURR MEAS LOWR, 92  
  CAL DATA, 93  
  CAL LEV, 93  
  CAL PASS, 93  
  CAL SAVE, 93  
  CAL STAT, 94  
  CAL VOLT, 94  
  CAL VOLT PROT, 94  
capacitance  
  compensation, 34  
  High, 34  
  Low, 34  
  switching, 34  
capacitor discharge limit, 35  
CC mode, 50  
character strings, 63  
characteristics, 134  
checklist, 25  
checkout procedure, 39  
cleaning, 26  
clearing errors, 51  
clearing protection, 51  
combine commands  
  common commands, 61  
  from different subsystems, 61  
  root specifier, 60  
command completion, 64  
command summary  
  format, 96  
  border, 96  
common command syntax, 91  
common commands, 111, 115  
  \*CLS, 124  
  \*ESE, 124  
  \*ESR?, 125  
  \*IDN?, 125  
  \*OPC, 125  
  \*OPT?, 126  
  \*PSC, 126  
  \*RCL, 126  
  \*RST, 127  
  \*SAV, 127  
  \*SRE, 128  
  \*STB?, 128  
  \*TRG, 129

## Index

- \*TST, 129
- \*WAI, 129
- compatibility
  - commands, 164
  - errors, 166
  - Fluke PM2811, 130
  - language, 163
  - power-on settings, 163
  - status model, 167
- controller connections, 38
- conventions used in this guide, 59
- conversion, ac line, 161
- CRD, 63
- crowbar circuit, 35
- current, 68
  - maximum, 68
  - measurement range, 72
  - measurements, 73
- current measurement detector, 102
- current measurement range, 52, 102
- current range, 47, 53
- current sinking, 22
- CV mode, 22, 50

### —D—

- damage, 26
- DC, 102
- DC current detector, 53
- determining cause of interrupt, 83
- device clear, 64
- DFI, 85
- DFI programming example, 159
- DFI signal, 36
- DIGIO, 54
- digital connector, 26, 36
- digital I/O, 36
  - connections, 37
- digital I/O port, 85
- digital output port, 54
- dimensions, 27
- disabling multiple units, 36
- discrete fault indicator, 85
- display commands, 95, 115
  - DISP, 95
  - DISP MODE, 95
  - DISP TEXT, 95
- downprogramming, 22
- DTR-DSR, 58

### —E—

- either, 122
- enabling the output, 67
- enter value, 50
- entry keys, 49
  - ←, 49
  - 0 ... 9, 49
  - Backspace, 49
  - Clear Entry, 49
  - Enter Number, 49

- error handling, 152
- error messages, 41
- error numbers, 147
- errors, 51
- example
  - controller using HP BASIC, 154
  - DFI programming, 159
  - IBM controller using National interface, 152
  - programs, 151
  - pulse measurement, 155, 156, 159
- external relays, 29

### —F—

- fault indicator
  - discrete, 84
  - remote inhibit, 84
- fetch commands, 71, 97
- FLT, 54, 85
- FLT output, 36
- Fluke PM2811 compatibility, 130
- format commands, 96
  - FORM, 96
  - BORD, 96
- front panel, 43
  - annunciators, 16
  - annunciators, 44
  - buffer size, 53
  - controls, 22
  - controls and indicators, 43
  - immediate actions, 16
  - keys, 44
  - measurements, 52
  - menus, 17
  - time interval, 53
  - using, 15
- function keys, 46
  - ▲, 46
  - Cal, 48
  - Current, 48
  - immediate action, 46
  - Input, 47
  - Meter, 47
  - OCP, 46
  - Output, 48
  - Output On/Off, 46
  - OV, 48
  - Prot Clear, 46
  - Protect, 48
  - Voltage, 48
- fuses, 28

### —G—

- generating measurement triggers, 76
- generating triggers, 70
- ground, earth, 20
- guide, user's, 19

## —H—

Hanning, 72, 104  
 header, 62  
   long form, 62  
   short form, 62  
 High measurements, 74  
 history, 6  
 HP BASIC controller example, 154  
 HP-IB, 54  
   address, 54, 57  
   address in programs, 151  
   capabilities of the dc source, 57  
   command library for MS DOS, 58  
   connections, 38  
   controller programming, 58  
   IEEE Std for standard codes, 59  
   IEEE Std for standard digital interface, 59  
   interface, 38  
   references, 58  
   **triggers**, 76  
 HP-IB address, 22

## —I—

impedance, 29  
 INH, 54, 84  
 INH input, 36  
 initialization, 67  
 initiate commands, 117  
   INIT CONT NAME, 117  
   INIT CONT SEQ, 117  
   INIT NAME, 117  
   INIT SEQ, 117  
 initiating measurement trigger system, 75  
 initiating output trigger system, 70  
 input  
   connections, 28  
   power, 20  
 inspection, 26  
 internal, 123  
**internal triggers**, 76  
 internally triggered measurements, 75

## —L—

language, 163  
 language dictionary, 87  
 language setting, 22  
**latching**, 107  
 lead resistance, 29  
 line fuse  
   replacing, 42  
 line voltage conversion, 161  
**live**, 107  
 load line, 23  
 load voltage drops, 29  
 local sensing, 34  
 location, 27  
 Low measurements, 74

## —M—

making measurements, 52, 71  
 manuals, 26  
 MAV bit, 83  
 maximum measurements, 74  
 measure commands, 71, 97  
   MEAS ARR CURR?, 97  
   MEAS ARR VOLT?, 97  
   MEAS CURR ACDC?, 98  
   MEAS CURR HIGH?, 98  
   MEAS CURR LOW?, 99  
   MEAS CURR MAX?, 99  
   MEAS CURR MIN?, 99  
   MEAS CURR?, 98  
   MEAS VOLT ACDC?, 100  
   MEAS VOLT HIGH?, 100  
   MEAS VOLT LOW?, 101  
   MEAS VOLT MAX?, 101  
   MEAS VOLT MIN?, 101  
   MEAS VOLT?, 100  
 measurement bandwidth, 47  
 measurement buffer, 47  
 measurement interval, 47  
 measurement ranges, 52  
 measurement samples, 71  
 measurement trigger system model, 75  
 measurements  
   Hanning window, 72  
   Rectangular window, 72  
 message terminator, 62  
   end or identify, 62  
   newline, 62  
 message unit  
   separator, 62  
 minimum measurements, 74  
 monitoring both phases of status transition, 84  
 moving among subsystems, 60  
 MSS bit, 83  
 multiple triggers, 70, 78

## —N—

National Instruments GPIB driver, 151  
 negative, 122  
 non-volatile memory  
   clearing, 55  
   storing, 45, 48  
 numerical data formats, 63

## —O—

OC, 51  
 OCP, 68  
 open sense protection, 32  
 operation status group, 81  
 optional header  
   example, 61  
 options, 20  
 OT, 51  
 output

## Index

- characteristic, 23
- compensation, 51
- connections, 28
- connector, 26
- control keys, 48
- current setting, 50
- enable, 51
- rating, 22
- voltage setting, 50
- output commands, 105
  - INST STAT, 130
  - OUTP, 105
  - OUTP TYPE, 107
  - OUTP DFI, 105
  - OUTP DFI SOUR, 105
  - OUTP PON STAT, 106
  - OUTP PROT CLE, 106
  - OUTP PROT DEL, 106
  - OUTP PROT TRIP?, 130
  - OUTP RI MODE, 107
- output compensation, 34, 48
- output queue, 83
- output trigger system model, 69
- OV, 51
- OVERCURRENT, 41
- overcurrent protection, 68
- OVERTEMPERATURE, 41
- OVERVOLTAGE, 41
- OVL, 41, 52
- OVP
  - circuit, 35
  - disable, 35
  - disabling, 35, 48

### —P—

- PON (power on) bit, 82
- positive, 122
- post-event triggering, 78
- power cord, 26, 28
- power receptacle, 20
- power-on conditions, 79
- power-on initialization, 67
- pre-event triggering, 78
- print date, 6
- program examples, 151
- programming parameters, 91
- programming status registers, 79
- programming the output, 67
- protection
  - FS, 51
  - OC, 51
  - OT, 51
  - OV, 51
  - RI, 51
- pulse measurement example, 155, 156, 159
- pulse measurement queries, 73

### —Q—

- queries, 61

- query
  - indicator, 62
- query protection, 51
- questionable status group, 82

### —R—

- rack mount kit, 20
- rack mounting, 27
- rear panel
  - at a glance, 14
  - connections, 36, 38
- recalling operating states, 55
- Rectangular, 72, 104
- remote front panel, 20
- REMOTE INHIBIT, 41, 84
- remote programming, 22
- remote sensing**, 29
  - connections, 30
  - continuity check, 30
  - OVP considerations, 32
  - stability, 32
  - with external relays, 30
  - with test fixture, 30
- repacking, 26
- resistance
  - sense leads, 32
- returning voltage or current data, 74
- RI, 51, 84
  - signal, 36
- RIDFI, 54
- rms measurements, 73
- root specifier, 62
- RQS bit, 83
- RS-232, 54
  - capabilities of the dc source, 57
  - connections, 38
  - data format, 57, 63
  - data terminator, 62
  - flow control, 58
  - interface, 38
- RTS-CTS, 58

### —S—

- safety class, 20
- safety warning, 20
- saving operating states, 55
- SCPI
  - command completion, 64
  - command syntax, 87
  - command tree, 60
  - common commands, 59
  - conformance, 65
  - data format, 63
  - device clear, 64
  - header path, 60
  - message structure, 61
  - message types, 61
  - message unit, 62
  - multiple commands, 60

- non-conformance, 65
- program message, 61
- references, 58
- response message, 61
- subsystem commands, 59, 87
- triggering nomenclature, 69, 75
- SCPI commands
  - at a glance, 18
- selecting measurement trigger source, 76
- selftest errors, 41
- sense commands, 97
  - SENS CURR DET, 102
  - SENS CURR RANG, 102
  - SENS FUNC, 103
  - SENS PROT STAT, 103
  - SENS SWE OFFS POIN, 103
  - SENS SWE POIN, 103
  - SENS SWE TINT, 104
  - SENS WIND, 104
- sense open, 32
- servicing operation status, 83
- servicing questionable status events, 83
- setting output trigger system, 69
- setting voltage/current, 50
- shorting switch, 36
- single triggers, 70, 76
- source commands, 105
  - [SOUR] CURR, 108
  - [SOUR] CURR LIM HIGH?, 130
  - [SOUR] CURR LIM LOW?, 130
  - [SOUR] CURR PROT STAT, 108
  - [SOUR] CURR PROT TRIP?, 131
  - [SOUR] CURR TRIG, 108
  - [SOUR] DIG DATA, 109
  - [SOUR] DIG FUNC, 109
  - [SOUR] VOLT, 109
  - [SOUR] VOLT LIM HIGH?, 131
  - [SOUR] VOLT LIM LOW?, 131
  - [SOUR] VOLT PROT, 110
  - [SOUR] VOLT PROT STAT, 110
  - [SOUR] VOLT PROT TRIP?, 131
  - [SOUR] VOLT TRIG, 110
- specifications, 133
- SRD, 63
- stability with remote sensing, 32
- standard event status group, 82
- status bit configurations**, 81
- status byte register, 82
- status commands, 111
  - STAT OPER COND?, 111
  - STAT OPER ENAB, 112
  - STAT OPER NTR, 112
  - STAT OPER PTR, 112
  - STAT OPER?, 111
  - STAT PRES, 111
  - STAT QUES COND?, 113
  - STAT QUES ENAB, 113
  - STAT QUES NTR, 114
  - STAT QUES PTR, 114
  - STAT QUES?, 113
- status model, 80

- subsystem commands syntax**, 88
- suffixes, 63
- support rails, 27
- system commands, 115
  - SYST ERR?, 115
  - SYST LANG, 115, 163
  - SYST LOC, 116
  - SYST REM, 116
  - SYST RWL, 116
  - SYST VERS?, 115
- system errors, 147
- system keys, 45
  - Address, 45
  - Error, 45
  - Interface, 45
  - Local, 45
  - RCL, 45
  - Save, 45
  - Shift, 45

## —T—

- transient response, 133
- trigger commands, 117
  - TRIG, 118
  - TRIG ACQ, 118
  - TRIG ACQ COUN CURR, 119
  - TRIG ACQ COUN VOLT, 119
  - TRIG ACQ HYST CURR, 120
  - TRIG ACQ HYST VOLT, 120
  - TRIG ACQ LEV CURR, 121
  - TRIG ACQ LEV VOLT, 121
  - TRIG ACQ SLOP CURR, 122
  - TRIG ACQ SLOP VOLT, 122
  - TRIG ACQ SOUR, 123
  - TRIG SEQ1 DEF, 123
  - TRIG SEQ2, 118
  - TRIG SEQ2 COUN CURR, 119
  - TRIG SEQ2 COUN VOLT, 119
  - TRIG SEQ2 DEF, 123
  - TRIG SEQ2 HYST CURR, 120
  - TRIG SEQ2 HYST VOLT, 120
  - TRIG SEQ2 LEV CURR, 121
  - TRIG SEQ2 LEV VOLT, 121
  - TRIG SEQ2 SLOP CURR, 122
  - TRIG SEQ2 SLOP VOLT, 122
  - TRIG SEQ2 SOUR, 123
  - TRIG SOUR, 118
- trigger offset, 78
- triggering output changes, 69
- triggers
  - multiple, 70, 77
  - single, 70, 76
- turn-on checkout, 138
- TYPE
  - CAP, 48
- types of SCPI commands, 59

## —U—

- UNR annunciator, 23

## Index

### —V—

verification  
  current measurement accuracy, 139  
  current programming, 139  
  equipment, 137  
  setup, 137  
  test record, 141  
  voltage measurement accuracy, 139, 140, 143, 145  
  voltage programming, 139, 140, 143, 145  
voltage, 68  
  maximum, 68  
  measurements, 73

voltage deviation with open sense, 33  
VXIplug&play, 19

### —W—

waiting for measurement results, 77  
warranty, 2  
wire  
  current ratings, 28

### —X—

XON-XOFF, 58

## HP Sales and Support Office

For more information, call your local HP sales office listed in your telephone directory or an HP regional office listed below for location of your nearest sales/support office.

### United States of America:

Hewlett-Packard Company  
Test and Measurement Organization  
5301 Stevens Creek Blvd  
Bldg 51L-5C  
Santa Clara, CA 95052-8059  
(800) 452 4844

### Asia Pacific:

Hewlett-Packard Asia Pacific Ltd.  
17-21/F Shell Tower, Time Square  
1 Matheson Street, Causeway Bay,  
Hong Kong  
(852) 2599 7070

### Australia/New Zealand:

Hewlett-Packard Australia Ltd.  
31-41 Joseph Street  
Blackburn, Victoria 3130  
Australia  
131 347 ext. 2902

### Canada:

Hewlett-Packard Canada Ltd.  
5150 Spectrum Way  
Mississauga, Ontario L4W 5G1  
(905) 206 4725

### Europe:

Hewlett-Packard  
European Marketing Center  
P.O. Box 999  
1180 AZ Amstelveen  
The Netherlands

### Japan:

Yokogawa Hewlett-Packard Ltd.  
Measurement Assistance Center  
9-1, Takakura-Cho, Hachioji-Shi,  
Tokyo, 192, Japan  
(81) 426 48 3860

### Latin America:

Hewlett-Packard  
Latin American Region Headquarters  
5200 Blue Lagoon Drive  
9th Floor  
Miami, Florida 33126  
U.S.A.  
(305) 267 4245/4220

## Manual Updates

The following updates have been made to this manual since the print revision indicated on the title page.

3/4/99

The note on page 33 has been replaced with two new paragraphs. Figure 3-5 has also been updated.

1/2/01

The serial number information on the title page has been updated. Also, the definition of the Transient Response specification on page 133 has been updated.